



Kwik Cut

Skid Loader Brush Cutter

Owner's Manual and Parts Book
(Originating with Serial Number 112-226)



Model Number: _____
Serial Number: _____
Date of Purchase: _____



LOFTNESS ™

LOFTNESS SPECIALIZED EQUIPMENT, INC.

LIMITED WARRANTY POLICY

The limited warranty policy begins upon delivery of the unit to the original customer.

The following Loftness products have a two (2) year limited warranty;

XLB10 Grain Bag Loader, Battle Ax L-series Skid Steer, Battle Ax S-series Skid Steer, Battle Ax H-series Skid Steer, Battle Ax Excavator 20-series, Battle Ax Excavator 30-series, Battle Ax Excavator 40-series, Battle Ax Excavator 50-series, Battle Ax Extreme, Bad Ax Skid Steer, Timber Ax Skid Steer, Stump Ax, BT20, Kwik Cut.

All other Loftness products have a one (1) year limited warranty.

If any Loftness product is used as rental or leased equipment the limited warranty period is for only 30 days from the delivery date to the original customers.

Loftness Specialized Equipment, Inc. ("LOFTNESS") warrants new LOFTNESS machinery and/or attachments at the time of delivery to the original purchaser, to be free from defects in material and workmanship when properly set up and operated in accordance with the recommendations set forth in the LOFTNESS Operator's Manual. The second year of limited warranty includes only parts, and not labor.

LOFTNESS' liability for any defect with respect to accepted goods shall be limited to repairing the goods at an authorized dealer or other LOFTNESS designated location, or replacing them as LOFTNESS shall elect. The above shall be in accordance with LOFTNESS warranty adjustment policies.

WARRANTY REQUIREMENTS

Warranty registration form must be filled out and returned to Loftness Specialized Equipment to validate all warranty claims.

To request a warranty claim, a return authorization from LOFTNESS must be obtained. The failed part may then be returned in an untampered status. This warranty does not include freight or delivery charges incurred when returning machinery for servicing. Dealer mileage, service calls and pick-up/delivery charges are the customer's responsibility.

LIMITATIONS OF WARRANTY

LOFTNESS products are designed to provide years of dependable service when proper use and maintenance is adhered to. The potential for misuse in many applications exists; therefore, a limited warranty is provided as follows.

This warranty shall not apply to any machine or attachment which shall have been repaired or altered outside the LOFTNESS factory or authorized LOFTNESS dealership or in any way so as in LOFTNESS' judgment, to affect its stability or reliability, nor which has been subject to misuse, negligence or accident, nor to any machine or attachment which shall not have been operated in accordance with LOFTNESS' printed instructions or beyond the company recommended machine rated capacity. LOFTNESS may elect to have an area representative evaluate the condition of the machine before warranty is considered.

In addition, this limited warranty provides no coverage for general wear or maintenance items, misuse, environmental conditions and/or contamination for which they were not designed or not intended, including but not limited to the following items;

Use of machine beyond its rated capacity, Conveyors, Improper knife replacement, Auger wear, Missing knives, Saw blades, Striking foreign objects, Brakes and brake pads, Lack of lubrication, Tires, Failures caused by running in an "out-of-balance" condition, Hydraulic hoses damaged by being caught in "pinch points" or by moving parts, and Damage caused by excessive force from the power unit.

EXCLUSIONS OF WARRANTY

Except as otherwise expressly stated herein, LOFTNESS makes no representation or warranty of any kind, expressed or implied. **The implied warranty of merchantability and fitness for a particular purpose are disclaimed, and excluded from this limited warranty.** The remedies set forth in this warranty are the sole and exclusive remedies available to any person under this warranty. LOFTNESS shall have no liability to any person for incidental, consequential or special damages of any description, whether arising out of express or implied warranty or any other contract, negligence, or other tort or otherwise. This exclusion of consequential, incidental and special damages is independent from and shall survive any finding that the exclusive remedy failed of its essential purpose. Upon purchase, the buyer assumes all liability, all personal injury and property damage resulting from the handling, possession or use of the goods by the buyer.

No agent, employee or representative of LOFTNESS has any authority to bind LOFTNESS to any affirmation, representation or warranty concerning its machinery and/or attachments except as specifically set forth herein. (October 2025)

LOFTNESS ™



To the Dealer:

In order to ensure compatibility / performance of the Loftness attachment and the customer's power unit, it is IMPERATIVE that this Pre-Delivery Inspection ("PDI") be completed using the customer's actual power unit.

PRE-DELIVERY INSPECTION

Dealer: By initialing each line I understand and promise that I have completed the following:

___ Verified the attachment is set up properly for customers power unit. (check model code with manual)

___ Greased all grease zerks till grease purges out of bearing.

___ Removed all shipping brackets.

___ Adjusted push bar out of shipping position. (if equipped) (full forward position recommended)

___ Installed head on customer's unit that will be running the attachment and set hydraulic flow per power unit manufacturer owner's manual for preferred flow.

___ Recorded the Serial Number / Make / Model of the power unit.

Power unit. S/N _____ Make _____ Model _____ GPM _____

___ Recorded the Serial Number and Model of the Loftness attachment. S/N _____ Model _____

___ Verified power unit manufacturer outlined Auxiliary coupler orientation for pressure, return & case drain line.

___ Verified/recorded rotor RPM at full throttle per model & chart in Loftness owner's manual. RPM _____

___ Performed an Auxiliary system pressure stall check on the power unit only and verified that max pressure rating is achieved per power unit manufacturer specifications. Recorded pressure observed _____ PSI

PDI completed by: _____ Print

Signed/Date

Contact Loftness factory if any of the tests are not within power unit or Loftness specifications.

DELIVERY

___ Showed customer all grease zerks.

___ Showed customer adjustable push bar options. (if equipped)

___ Showed customer how to properly engage hydraulics to operate attachment.

___ Reviewed owner's manual, all on-product warnings and instructions, and safe operation with customer.

___ Assisted customer with completing / submitting Warranty Registration Form to Loftness by one of the below options.

Dealer also needs to submit a copy of this completed PDI to Loftness and maintain the copy in owner's manual for unit.

Mail to:

Loftness Specialized Equipment
PO Box 337
Hector, MN 55342

Delivered to Customer by: _____ Print

Signed/Date

Email to: registration@loftness.com

LOFTNESS COPY



To the Dealer:

In order to ensure compatibility / performance of the Loftness attachment and the customer's power unit, it is IMPERATIVE that this Pre-Delivery Inspection ("PDI") be completed using the customer's actual power unit.

PRE-DELIVERY INSPECTION

Dealer: By initialing each line I understand and promise that I have completed the following:

___ Verified the attachment is set up properly for customers power unit. (check model code with manual)

___ Greased all grease zerks till grease purges out of bearing.

___ Removed all shipping brackets.

___ Adjusted push bar out of shipping position. (if equipped) (full forward position recommended)

___ Installed head on customer's unit that will be running the attachment and set hydraulic flow per power unit manufacturer owner's manual for preferred flow.

___ Recorded the Serial Number / Make / Model of the power unit.

Power unit. S/N _____ Make _____ Model _____ GPM _____

___ Recorded the Serial Number and Model of the Loftness attachment. S/N _____ Model _____

___ Verified power unit manufacturer outlined Auxiliary coupler orientation for pressure, return & case drain line.

___ Verified/recorded rotor RPM at full throttle per model & chart in Loftness owner's manual. RPM _____

___ Performed an Auxiliary system pressure stall check on the power unit only and verified that max pressure rating is achieved per power unit manufacturer specifications. Recorded pressure observed _____ PSI

PDI completed by: _____ Print

Signed/Date

Contact Loftness factory if any of the tests are not within power unit or Loftness specifications.

DELIVERY

___ Showed customer all grease zerks.

___ Showed customer adjustable push bar options. (if equipped)

___ Showed customer how to properly engage hydraulics to operate attachment.

___ Reviewed owner's manual, all on-product warnings and instructions, and safe operation with customer.

___ Assisted customer with completing / submitting Warranty Registration Form to Loftness by one of the below options.

Dealer also needs to submit a copy of this completed PDI to Loftness and maintain the copy in owner's manual for unit.

Mail to:

Loftness Specialized Equipment
PO Box 337
Hector, MN 55342

Delivered to Customer by: _____ Print

Signed/Date

Email to: registration@loftness.com

CUSTOMER COPY

LOFTNESS ™

Table of Contents

Warranty

Table of Contents

Ordering Code

Ordering Code	1
Kwik Cut Brush Cutter (Example)	1

Introduction

Owner Information	3
Warranty Policy	3
Serial Number Location	3
Owner's Manual Access	3
Kwik Cut Features	4

Safety Instructions

Safety First	5
Owner's Responsibility	5
Mandatory Shut-Down Procedure	6
Safety Rules	6
Operating Safety	6
Maintenance Safety	7
Hydraulic Safety	8
California Proposition 65 Warning	8
Kwik Cut Identification	9
Safety Decals	10
Locations	10
Defined	11

Set-up Instructions

Removing Shipping Hardware	13
Installing the Kwik Cut to the Loader	13
Hydraulic Connections	14
Case Drain Vent	14
Securing the Lift Limit Safety Chain	14
Checking Disc Rotation	16

Operating Instructions

Getting Started	17
Pre-start Checklist	17
Becoming Familiar with the Kwik Cut	17
Operation	18
Overview	18
General Cutting Instructions	18
Stopping the Kwik Cut	18
Detaching the Kwik Cut from the Loader	18
Hydraulic Hose Storage	19

Table of Contents

Operating Instructions (Cont'd)

Transporting	19
Road Travel	19
Hauling	19

Maintenance

General Maintenance	21
Break-In Schedule	21
Maintenance Schedule	21
Lubrication	21
Changing Bearing Support Gear Lube	21
Removing Motor Cover	22
Lifting Points	23
Disc Removal	23
Motor Removal	24
Blade and Tooth Access Plate	24
Blade and Tooth Removal/Replacement	25
Cutting Blade	25
Cutting Teeth	26
Storage	26
End of Season	26
Beginning of the Season	26
GPM Chart	27
Radial Piston Motor 5000 PSI	27
Troubleshooting	28

Parts Identification

Cutter Door; Skid Plates; Access Plate	30
Drive Motor; Motor Cover; Cutter	32
Cutter Assembly (201430)	34
Hydraulics	36
SAI Motor (209767)	38
Seal, SAI Bearing Support Shaft (212126)	39
Machine Decals and Signs	40

Appendix

Specifications	43
Dimensions	44
Torque Specifications	45
Inches Hardware and Lock Nuts	45
Metric Hardware and Lock Nuts	46

Ordering Code

Kwik Cut Brush Cutter (Example)

The ordering code will consist of two numbers (machine size), two letters (machine type), two numbers (machine series), and one number (motor system). An example for a brush cutter of this type would be as shown below.

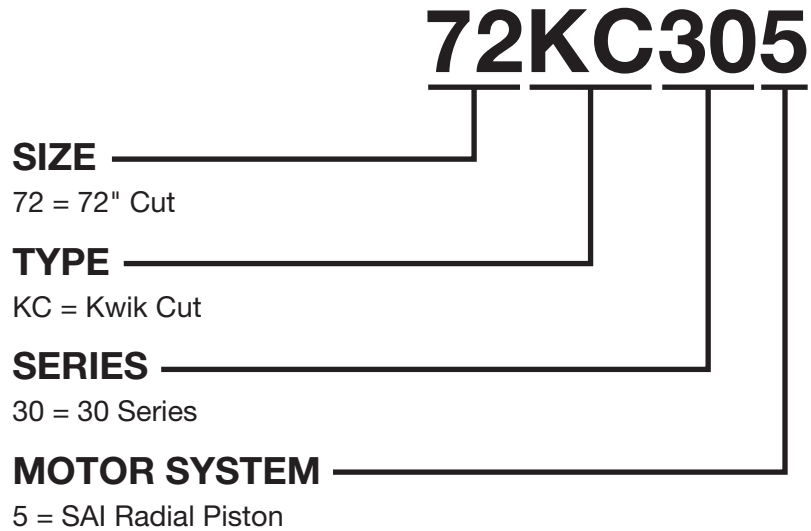



Owner Information

Thank you for your decision to purchase a Kwik Cut Brush Cutter from Loftness. To ensure maximum performance of your machine, it is mandatory that you thoroughly study the owner's manual and follow its recommendations. Proper operation and maintenance are essential to prevent injury or damage and to maximize machine life.

The Loftness Kwik Cut Brush Cutter is an effective, reliable machine ideally used for land clearing and vegetation control. The 72 inch diameter disc can cut down trees up to 10 inches in diameter and the carbide teeth on the underside of the disc can grind stumps of similar size. For best results, operate the machine as low to the ground as possible without the teeth striking ground or other obstructions. Lifting or tilting the brush cutter increases the risk of flying debris. Because of the high speed of the disc, the life of the blades and teeth will be reduced if it is operated in rocky terrain or in areas where many obstacles are present. Areas to be cleared should be free of debris such as rocks, bottles, large branches etc. The blades and teeth cut and pulverize the grass, weeds, brush and small trees.

Operate and maintain this machine in a safe manner and in accordance with all applicable local, state, and federal codes, regulations and/or laws, and in compliance with on-product labeling and these instructions.

Make sure that all personnel have read this owner's manual and thoroughly understand safe and correct operating, installation and maintenance procedures.

Continuous improvement and advancement of Loftness products may result in changes to your equipment that may not be reflected in this publication. Loftness reserves the right to make product improvements to the machine at any time. Although great care has been taken to ensure the accuracy of this publication, Loftness does not assume any liability for errors or omissions.

Warranty Policy

Be sure to read and understand the Warranty Policy at the beginning of this manual. It is also important that you fill out the Warranty Registration form(s) completely with your dealer so as not to void the warranty.

Serial Number Location

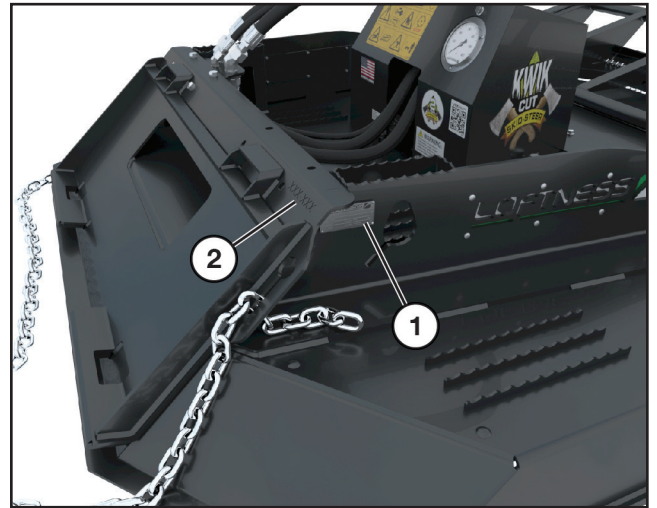

The machine serial number is shown on the tag (1), and is also stamped into the rear of the machine frame (2).

Always use your model and serial number when requesting information or when ordering parts.

Owner's Manual Access



The Kwik Cut is shipped with a printed owner's manual. The manual must be available to all operators. Keep in a safe, dry location.

To access a digital owner's manual, use a smartphone to scan the QR code (1) located below the pressure gauge. This code will link to the Kwik Cut owner's manual on the Loftness website.

Introduction

Kwik Cut Features

- 150cc Instant Torque Radial Piston Motor
- 28-45 GPM up to 5000 PSI
- 50-110 Hydraulic Horsepower Required
- Pressure Gauge to Monitor Capacity
- 72 inch Diameter Disc
- Four Dual-Edge Beveled Blades (Reversible)
- 18 Bolt-on Replaceable Carbide Teeth for Stump Grinding
- Bearing Anti-wrap Protection
- Premium Strength Steel Body and Disc
- Floating Door - Doubles as a Push Bar and Debris Control
- Universal Skid-Steer Mount
- Hoses Included (Couplers Not Included)
- Height Limiting Safety Chain

Safety First

	<h3>Safety Alert Symbol</h3> <p>This message alert symbol identifies important safety messages on the machine and in the owner's manual. When you see this symbol, be alert to the possibility of personal injury and carefully read the message that follows.</p>
---	--

In the owner's manual and on decals used on the machine the words **DANGER, WARNING, CAUTION, IMPORTANT, and NOTE** are used to indicate the following:

DANGER: This word warns of immediate hazards which, if not avoided, will result in severe personal injury or death. The color associated with Danger is RED.



WARNING: This word refers to a potentially hazardous situation which, if not avoided, could result in severe personal injury or death. The color associated with Warning is ORANGE.

CAUTION: This word refers to a potentially hazardous or unsafe situation that, if not avoided, may result in minor or moderate injury. It may also be used to alert against unsafe practices. The color associated with Caution is YELLOW.

IMPORTANT: Highlights information that must be heeded.

NOTE: A reminder of other related information that needs to be considered.

If Safety Decals on this machine are ISO two panel pictorial, decals are defined as follows:

- The first panel indicates the nature of the hazard.
- The second panel indicates the appropriate avoidance of the hazard.
- Background color is YELLOW.
- Prohibition symbols such as  and  if used, are RED.

Be certain all machine operators are aware of the dangers indicated by safety decals applied to the machine, and be certain they follow all safety decal instructions. Contact Loftness for safety decal replacement.

Loftness cannot anticipate every possible circumstance that may involve a potential hazard. The warnings in this owner's manual are not all-inclusive.

Owner's Responsibility

Due to the potential danger of flying debris, it is the owner's responsibility and is **ABSOLUTELY MANDATORY** that **IMPACT-RESISTANT SHIELDING** be installed on the machine to protect the operator.

It is **ABSOLUTELY MANDATORY** that all personnel read and follow all safety precautions before operating the machine and attachment.

Make sure that all personnel have read this owner's manual, and thoroughly understand safe and correct installation, operation, and maintenance procedures.

Operate and maintain this machine in a safe manner and in accordance with all applicable local, state, and federal codes, regulations and/or laws; and in compliance with on-product labeling and this owner's manual instructions.

Make sure that all personnel know how to stop the machine and attachment by disengaging all controls. See "Mandatory Shut-Down Procedure" on page 6.

Make sure the attachment is installed on the machine correctly before being placed in service. At regular intervals thereafter, the attachment should be serviced in accordance with procedures outlined in this owner's manual.

Safety Instructions

Mandatory Shut-Down Procedure

- Stop the machine and attachment on a level surface and lower the attachment to the ground.
- Move throttle to idle position.
- Disengage all power to the attachment.
- Shut off engine and remove the key.

Wait until the disc has stopped completely before inspecting the attachment.

Safety Rules

These are general safety considerations. Additional precautions may be necessary to operate your machine in a safe manner. Be certain you are operating your machine in accordance with all safety codes, OSHA rules and regulations, insurance requirements and local, state, and federal laws.

Operating Safety

- Do not start, operate, or work on this attachment until you have carefully read and thoroughly understand the contents of this manual and the operator's manual for your loader.
- Read and observe all warning decals on the machine before attempting to operate the attachment. Do not attempt to operate this attachment unless all factory devices and decals are in place. Keep safety decals clean of dirt and grime. Keep all guards, shields and decals in place.
- Do not operate the Kwik Cut without the lift limit safety chain in place and properly secured.
- Become familiar with all safety devices and controls on the machine and attachment before attempting to operate. Know how to stop the machine and attachment before starting it.
- Do not allow anyone to operate the attachment until they have read the owner's manual and is completely familiar with all safety precautions and controls. Keep the work area clear of all unauthorized personnel.
- Because of the potential safety hazard to eyes from hydraulic leaks and/or flying debris, use of protective eyewear is absolutely mandatory for operator and others in the work area.
- Do not wear loose hanging clothes, neckties or jewelry around rotating parts. Long hair is to be placed under a cap or hat. These precautions will help prevent you from becoming caught in any moving parts on the machine and attachment.
- Do wear safety glasses, ear protection, respirators, gloves, hard hats, safety shoes and other protective clothing when required.
- Do not allow persons under the influence of alcohol, medications, or other drugs that can impair judgment or cause drowsiness to operate or maintain the machine.
- Never allow children to operate the equipment.
- Keep children, bystanders and other workers off and away from the machine and attachment during operation. No riders allowed.
- Use the handholds and step plates when getting on and off the machine to prevent falls. Keep steps and platform cleared of mud and debris.
- Always have an operator in the machine while the attachment is in operation. Never leave the machine and attachment running and unattended.
- Keep your feet on the pedals, (floor plates) seat belt fastened snugly and seat bar lowered, (if equipped), when operating the attachment.
- Always use an approved roll bar and seat belt for safe operation. Overturning a machine without a roll bar and seat belt can result in injury or death.
- Operate the attachment only from the operator's seat.
- Before leaving the operator's position for ANY reason or allowing anyone to approach the machine and attachment, always perform the mandatory shutdown procedure.
- Keep hands and feet clear! Never step over or climb over the attachment while the engine is running; entanglement could occur.
- Disengage auxiliary hydraulics and place all machine controls in neutral and engage the parking brake before starting the engine.

Safety Rules (Cont'd)

Operating Safety (Cont'd)

- Remove all foreign objects from the work area such as bottles, rocks, wire, etc., that might become tangled in the disc, causing damage to the machine or be thrown striking other objects.
- Never attempt to make any adjustments while the attachment is running or the key is in the "ON" position in the machine. Before leaving the operator's position, disengage power to the attachment, shut off engine and remove ignition key.
- Repeated impact of the teeth with hard objects can cause excessive wear and damage to the loader or attachment. Be sure to maintain recommended ground clearance as specified in this manual.
- Should excessive vibration occur, disengage the auxiliary hydraulics immediately and shut off engine. Do not continue to operate the attachment until the problem has been determined and corrected.

Maintenance Safety

- Do not work on this attachment until you have carefully read and thoroughly understand the contents of this manual and the operator's manual for your loader.
- Before inspecting, cleaning, lubricating, adjusting or servicing any part of the attachment, always exercise the Mandatory Shut-Down Procedure. See "Mandatory Shut-Down Procedure" on page 6. After service has been performed, be sure to restore all guards, shields and covers to their original position.
- Never attempt to lubricate, or make any adjustments while the loader or attachment is running, or the key is in the "ON" position in the machine. Before leaving the operator's position, disengage power to the attachment, shut off engine and remove ignition key.
- When performing any maintenance, make sure the area is clear of any distracting objects. Keep work areas clean and free of grease and oil to avoid slipping or falling.
- Before working under the attachment, be certain it is securely blocked!

- Do not smoke while servicing the machine.
- Do not touch loader or any attachment parts which might be hot from operation. Allow such parts to cool before attempting to maintain, adjust or service.
- Make sure all controls, (levers, pedals and switches), are in NEUTRAL position before starting the engine.
- Before leaving the operator's position for ANY reason or allowing anyone to approach the machine and attachment, always perform the mandatory shutdown procedure.
- Periodically check all guards, shields and structural members. Replace or repair anything that could cause a potential hazard.
- Do not replace components or parts with other than factory-recommended service parts. To do so may decrease the effectiveness of the machine and/or void the warranty.
- It is the operator's responsibility to be aware of machine and attachment operation and work area hazards at all times.
- Never operate the attachment without adequate light and visibility.
- Keep hands and feet clear! Never step over or climb over the attachment while the disc is engaged or the engine is running; entanglement could occur.
- Operators are responsible to know the location and function of all guards and shields including but not limited to the drive and disc. Operators are responsible to make certain that all guards are in place when operating the machine and attachment.
- Operators are responsible to be aware of safety hazard areas and follow instructions on warning, caution, or danger decals applied to the machine.
- Know the area before operating the machine. Be aware of power lines or other equipment.

Safety Instructions

Safety Rules (Cont'd)

Hydraulic Safety

	WARNING: <i>Contact with high pressure fluids may cause fluid penetration and burn hazards. Fluid that is under pressure can penetrate body tissue. Fluid penetration can cause serious injury and possible death. If fluid is injected into the skin, seek medical attention immediately!</i>
---	---

- Always wear safety goggles or glasses when working on the hydraulic system to avoid eye injury.
- The hydraulic system is under high pressure. Make sure all lines and fittings are tight and in good condition. These fluids escaping under high pressure can have sufficient force to penetrate skin and cause serious injury.
- Never check for leaks by using any part of your body to feel for escaping fluid.
- To prevent serious personal injury from escaping high pressure fluid, never attempt to inspect, service or disassemble any part of the hydraulic system until all pressure has been relieved from the system.

California Proposition 65 Warning

	WARNING: <i>This product can expose you to Mineral Oil, which is known to the State of California to cause cancer. For more information, go to www.p65warnings.ca.gov.</i>
---	---

A decal with this warning statement is adhered to the machine. If the decal should become worn or missing, replace immediately.

Kwik Cut Identification

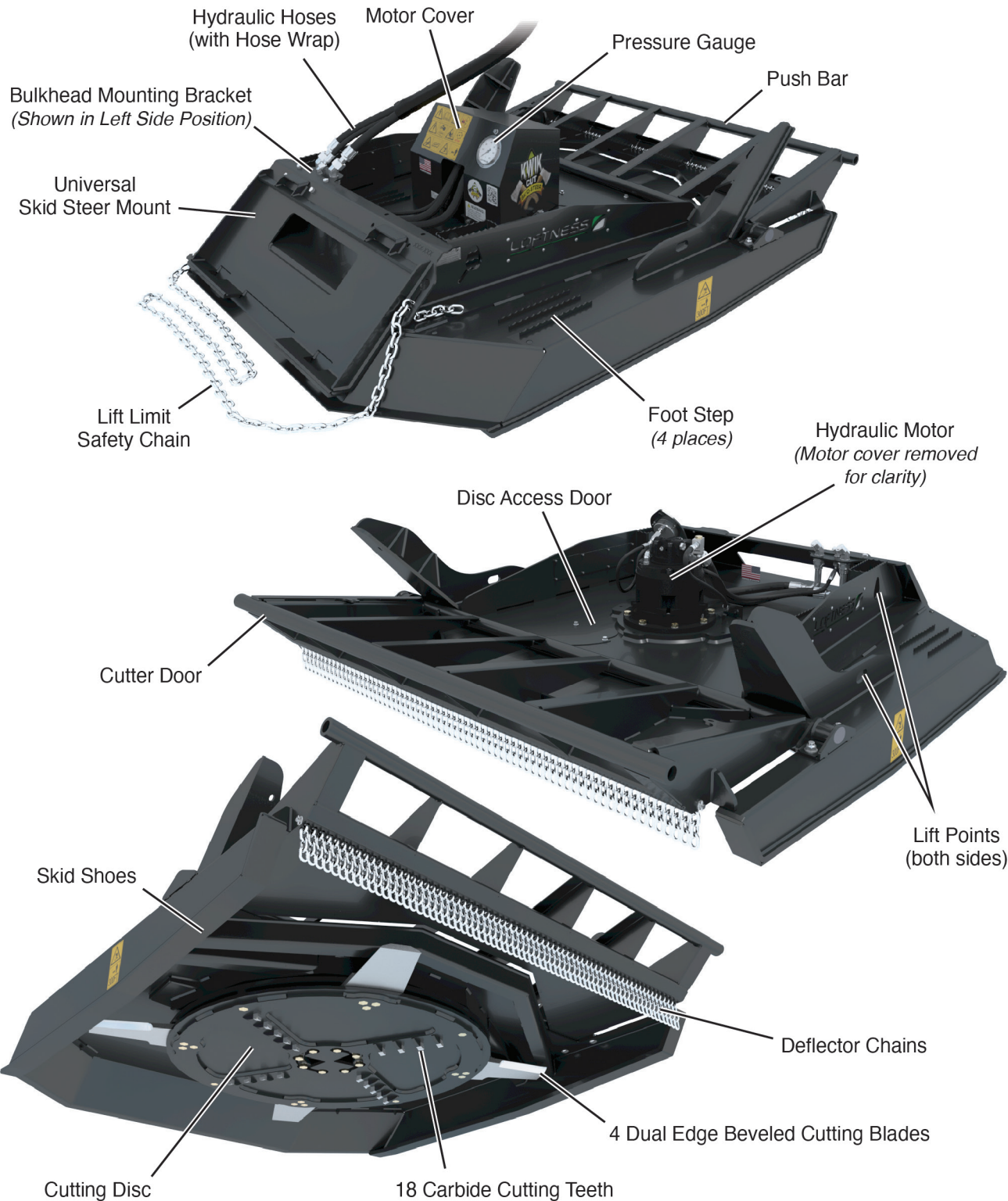

Safety Instructions

Safety Decals

Check and replace any worn, torn, hard to read or missing safety decals on your machine.

Locations

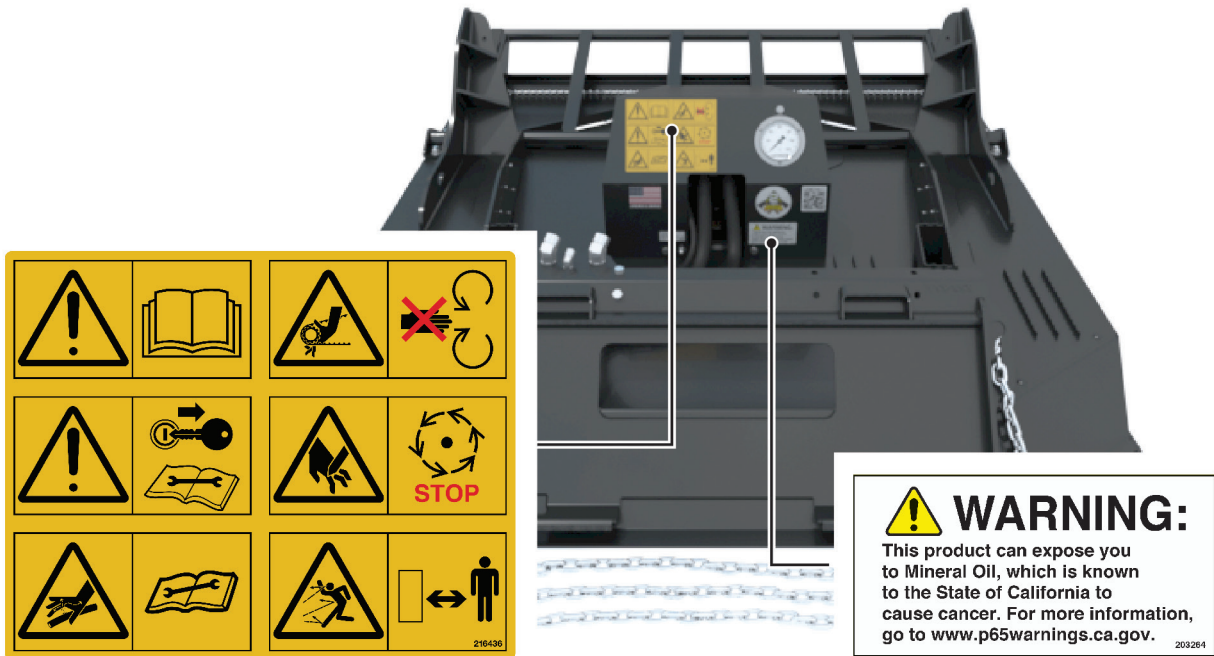

Safety Decals

Defined

Loftness decal part number - 216436	
	<p>Caution - General</p> <ul style="list-style-type: none">• Read and understand operator's manual before using this machine.• Do not operate machine in a manner for which it was not intended.• Failure to follow operating instructions could result in death or serious injury.
	<p>Caution - General</p> <ul style="list-style-type: none">• Shut off engine and remove key before performing maintenance or repair work.
	<p>Danger - Skin Puncture Hazard</p> <ul style="list-style-type: none">• Protect hands and body from high pressure fluids.• High-pressure fluid leaks can penetrate skin and cause severe injury, burns, or death. Seek immediate medical attention if fluid is injected into the skin.• Read operator's manual for proper service procedures.
	<p>Danger - Hand and Arm Entanglement</p> <ul style="list-style-type: none">• Keep hands and feet away from moving parts.• Do not open or remove safety shields while engine is running.• Turn off engine before servicing.
	<p>Danger - Cutting Hazard</p> <ul style="list-style-type: none">• Keep hands and feet away from cutting knives.• Wait until all machine components have completely stopped before servicing.
	<p>Danger - Thrown or Flying Object Hazard</p> <ul style="list-style-type: none">• Flying debris can cause severe injury or blindness.• Keep all bystanders, coworkers, and animals a safe distance from the machine during operation.• Always wear eye protection and required personal protective equipment (PPE).

Safety Instructions

Safety Decals (Cont'd)

Defined (Cont'd)

Loftness decal part number - 216437



Danger - Thrown or Flying Object Hazard

- Flying debris can cause severe injury or blindness.
- Keep all bystanders, coworkers, and animals at least 300 ft. (91 m) away from the machine during operation.
- Always wear eye protection and required personal protective equipment (PPE).

Loftness decal part number - 203264

For Kwik Cut models operating in the State of California



Warning - California Proposition 65

- This label is a regulatory requirement for machines operating within the State of California. It informs personnel of chemical exposure risks, allowing operators and technicians to implement necessary safety measures during equipment operation and servicing.

Set-up Instructions

Removing Shipping Hardware

The Kwik Cut is shipped with the door secured in the upright position. Follow the procedure below to get the cutter door into the operating position.

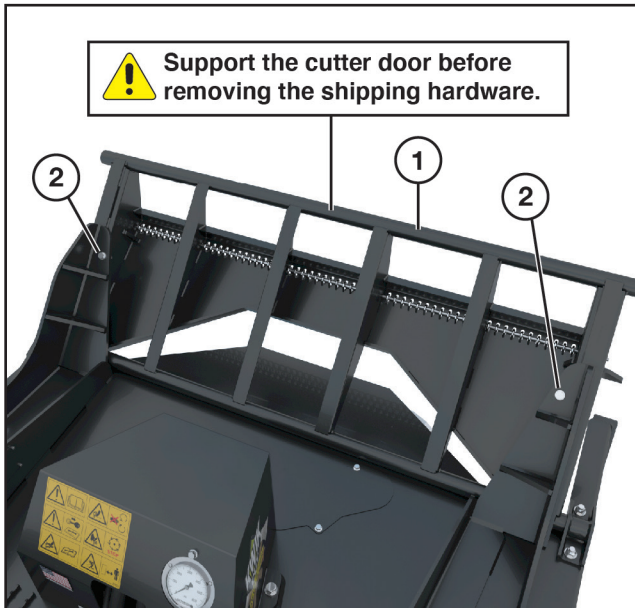

Safely support the door (1) to prevent it from falling when the hardware is removed.

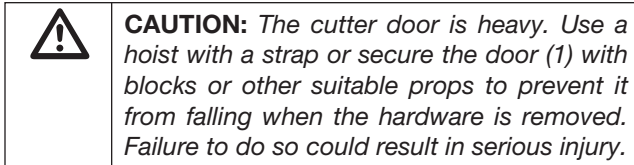

Remove the nuts, bolts, and washers (2) at the two locations shown above.

Slowly lower the door until it rests on the deck skids.

Installing the Kwik Cut to the Loader

Fully raise the attachment-locking levers on the loader mounting plate.

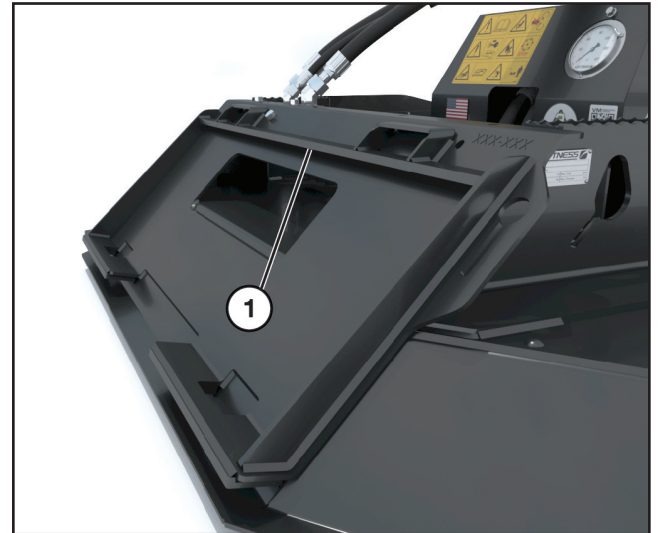

Tilt the loader mounting plate ahead. Drive forward with the loader and hook the top edge of the loader mounting plate under the top flange (1) on the Kwik Cut mounting plate. Be careful not to damage the locking levers on the loader mounting plate.

Tilt the loader mounting plate back until the Kwik Cut mounting plate is firmly against the loader mounting plate, but Do Not lift the attachment off the ground.

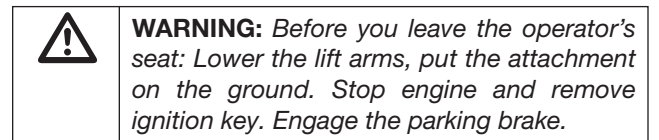

Fully lower the attachment-locking levers on the loader mounting plate.

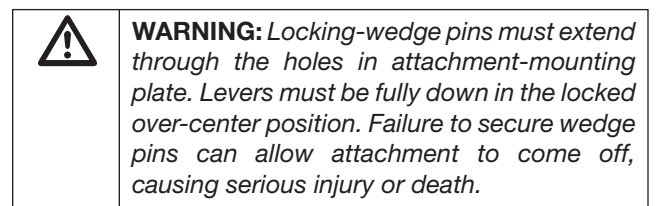

Set-up Instructions

Installing the Kwik Cut to the Loader (Cont'd)

Hydraulic Connections

 **WARNING:** Hydraulic Lines. Protect hands and body from high pressure fluids. Pressurized fluids can penetrate the skin. Disconnect and lock out power source before disconnecting and/or connecting hydraulic hoses.

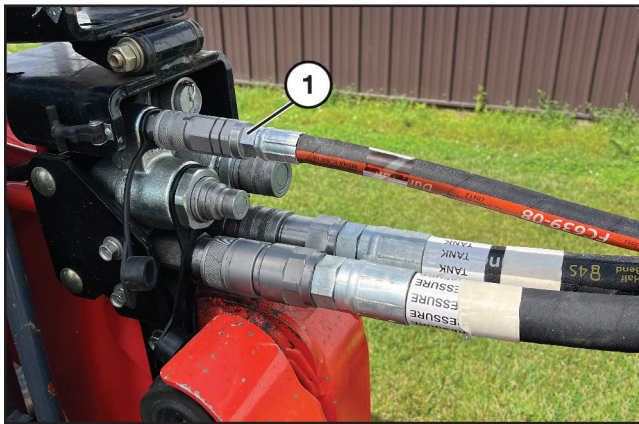

Install the Kwik Cut quick couplers to the loader.

NOTE: The case drain quick coupler (1) must be connected to the loader's auxiliary hydraulic system for proper operation of the Kwik Cut.

IMPORTANT: It is the owner's responsibility to assure that the hydraulic hoses from the power unit to the attachment are not caught in pinch points, or in any way damaged by moving parts.

Case Drain Vent



IMPORTANT: DO NOT cap the case drain vent (1). Capping it may cause pressure buildup in the hydraulic system, which could damage the motor and seals.

Securing the Lift Limit Safety Chain



The lift limit chain (1) is a safety device designed to prevent the Kwik Cut from being raised beyond a safe operating height.

Follow the procedure outlined on the next page for proper installation of the lift limit chain.

(Procedure continued on following page.)

Installing the Kwik Cut to the Loader (Cont'd)

Securing the Lift Limit Safety Chain (Cont'd)



DANGER: During operation, Do not raise brush cutter higher than 24 in. (61 cm) off the ground. Raising the cutter higher can cause serious bodily injury and/or death.

NOTE: For safety and ease of installation, it is recommended that two people perform the lift limit safety chain installation and adjustments.



DANGER: Always secure the brush cutter with solid supports before working around or under a raised deck. Never work under equipment supported by hydraulics. Follow the directions written in this procedure carefully. Failure to do so could result in injury or death.

Start loader.

Raise the Kwik Cut until the skid shoes are approximately 25 in. (63.5 cm) off the ground and ensure it is level.

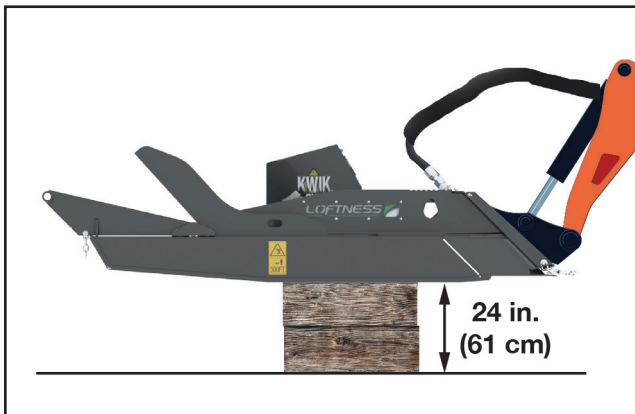

Place 24 in. (61 cm) blocks underneath the right and left side skid shoes, then lower the brush cutter onto the blocks.

Turn off the loader.

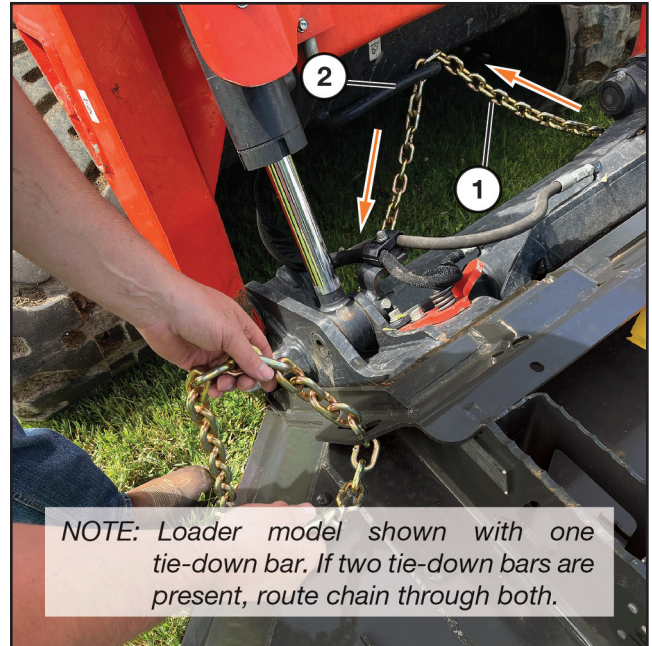

NOTE: Loader model shown with one tie-down bar. If two tie-down bars are present, route chain through both.

Route the end of the lift limit safety chain (1) through tie-down bar (2) located on the front of the loader, and then to the right side of the machine.

NOTE: The tie-down bar design varies by loader make and model. If two bars are present, route the chain through both.

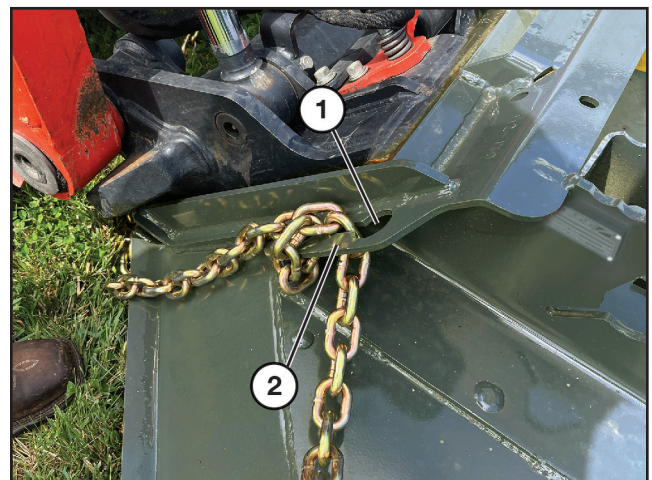

Pull the chain tight and route it through the hole (1) in the brush cutter frame. Secure it in place by sliding a link into the slot. Then wrap it around the welded bracket (2) once and route through the hole again, securing it in place by sliding a link into the slot.

(Procedure continued on following page.)

Set-up Instructions

Installing the Kwik Cut to the Loader (Cont'd)

Securing the Lift Limit Safety Chain (Cont'd)

Start the loader.

Raise the brush cutter until the safety chain is tight.

Measure the distance from the ground to the bottom of the skid shoes. The distance should be approximately 24 in. (61 cm). If not, lower the brush cutter down onto the blocks.

Turn off the loader.

Make the necessary adjustments by locking a different chain link into the slot.

Start the loader and repeat the process until the skid shoes are 24 in. (61 cm) off of the ground.

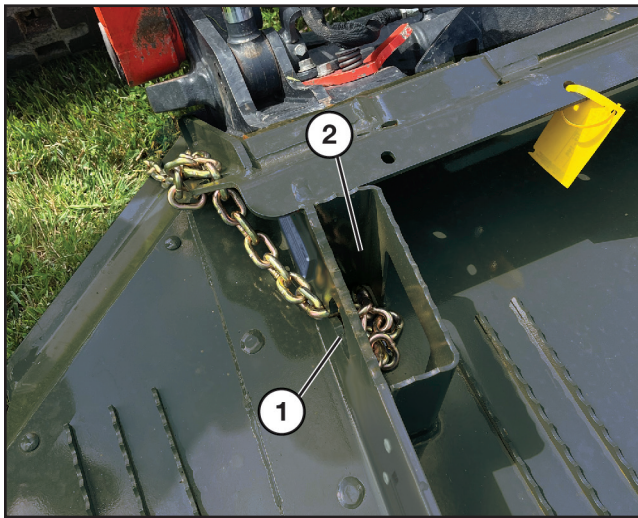

Route the excess chain through the opening in the frame (1) and store it inside the step plate (2). Secure it by sliding a link into the slot.

Checking Disc Rotation



Raise the brush cutter off the ground and place blocks underneath the skids. Lower the brush cutter down on the blocks.

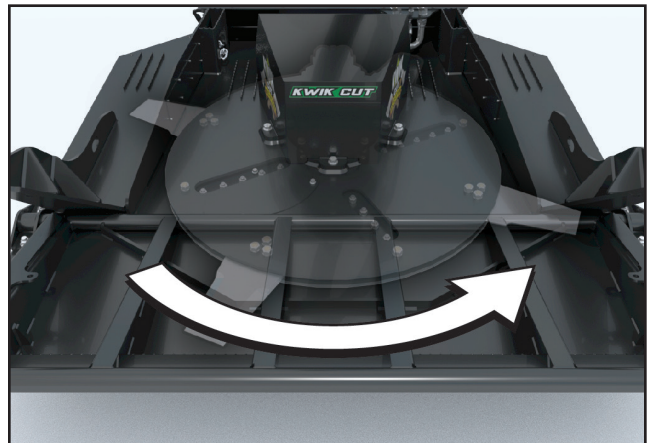
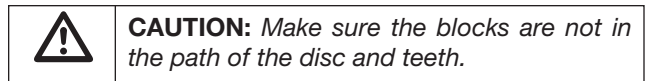

Engage the loader auxiliary hydraulics, the disc should start rotating in a counter clockwise direction as viewed looking down from the top of the disc.

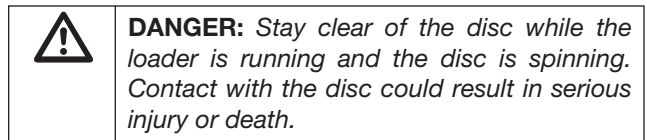

NOTE: If the disc rotates in the wrong direction, shut down the loader and verify that the quick couplers are connected properly. Re-install the couplers on the loader and test for correct disc rotation.

Operating Instructions

Getting Started

Pre-start Checklist



DANGER: Shut down and lock out power from the power unit before performing the pre-start checklist. Failure to do so could result in serious injury or death.

Visually inspect the unit before starting the machine up. Check for loose or missing parts. Check all bolts for tightness.

- Make sure the Kwik Cut is properly attached to the power unit, including the lift limit safety chain.
- Check all bolts, nuts and set screws for tightness.
- Inspect the blades and teeth. If any are damaged or missing, replace. Make sure they are free of dried mud, string, wire, etc.
- Review operator's manual.



WARNING: Never operate the Kwik Cut with out-of-balance blades or teeth. Check to make certain there are no broken or missing blades or teeth and that all are installed securely.



WARNING: DO NOT operate the Kwik Cut with safety guards and/or deflector chains removed.



WARNING: DO NOT operate the Kwik Cut without the lift limit safety chain in place and properly secured.



WARNING: Due to the potential danger of flying debris, it is the owner's responsibility and is "ABSOLUTELY MANDATORY that IMPACT-RESISTANT SHIELDING" be installed on the machine to protect the operator.

Becoming Familiar with the Kwik Cut

- Start the machine in a clear, open area and become familiar with the controls. Run throttle at half speed. Raise the brush cutter only slightly until comfortable with the machine.



WARNING: Lifting or tilting the Kwik Cut increases the risk of flying debris. Ensure the lift limit safety chain is connected.



DANGER: Keep hands and feet out! Do not step on or climb over the unit while machine is in operation, or engine is running. Do not carry passengers.



WARNING: Do not operate the attachment above the rated RPM. Check with your Loftness dealer to be sure your attachment is set-up with the correct hydraulic motor to match the hydraulic flow GPM (Gallons Per Minute) of your machine.



WARNING: Flying debris can gather on the power unit and needs to be cleaned off, especially around the radiator, oil cooler screens, engine compartment, and exhaust areas. Periodic cleaning will help prevent the possibility of fire.



DANGER: DO NOT allow ANY people or animals within 300 feet of the work area while operating this machine.



WARNING: Always stop engine and remove the key before leaving operators seat.

IMPORTANT: Upon initial use, to reduce stress on brand new cutting blades and teeth, and to extend their life, allow 2-3 hours of light-duty work for them to wear gradually. Keep the disc level and above ground when cutting, and avoid all contact with hard objects, rocks, and dirt.

Operating Instructions

Operation

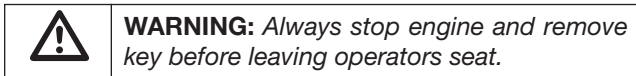

Overview

The most efficient cut is from the blades as those are outermost and moving faster.

After cutting, mulching, or grinding material allow for the disc to regain momentum before proceeding.

NOTE: Because of the high speed of the disc, the life of the blades and teeth will be reduced if it is operated in rocky terrain or in areas where many obstacles are present.

To reduce disc jams, approach brush and trees at a slow speed.

Allow the disc to get back up to speed before mulching the next tree.

In wet conditions, operate at a slower speed and periodically inspect the cutting head for caking and clogging in the disc area.

General Cutting Instructions

- Operate the Kwik Cut as low to ground as possible without the blades and teeth striking the ground or other obstructions.

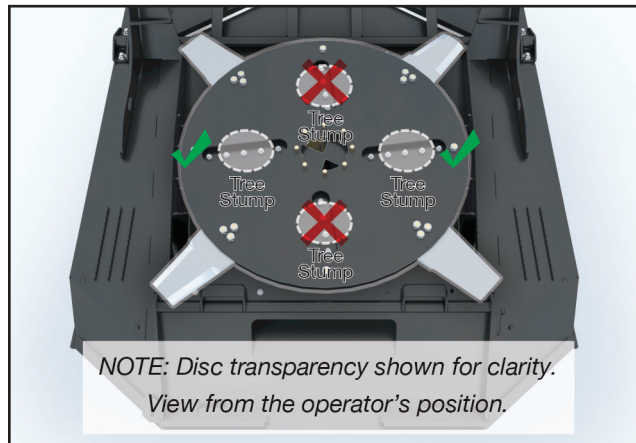

- Use the carbide teeth on the underside of the disc for grinding stumps up to 10 in. (25.4 cm) in diameter.

Position the Kwik Cut so the stump is either to the left or right side of the drive center as shown above. Stumps can be cut to ground level by slowly lowering the head to process.

- To groom the area, raise the Kwik Cut slightly and angle the front of the disc toward the ground allowing the disc to skim the ground. Back over debris for a finished look.

Stopping the Kwik Cut

Before making any inspections or performing any maintenance, disengage the power unit's hydraulics and wait for the disc to come to a complete stop.

Lower the Kwik Cut to the ground.

Before dismounting the power unit, shut off the engine set the parking brake and remove the key.

Detaching the Kwik Cut from the Loader

Park on clear, level ground with enough room to lower the Kwik Cut.

Disconnect the loader from the Kwik Cut.

Clean the Kwik Cut after every use.

Hydraulic Hose Storage

When not in use, protect the hose couplers by laying the hydraulic hoses around the motor cover, ensuring the couplers do not come in contact with the machine, ground, or any other surface.

Transporting

Road Travel



CAUTION: Always comply with all federal, state and local laws when traveling on public roads whether at night or during the day. Use accessory lights and devices for adequate warning to operators of other vehicles.

Disengage hydraulics.

Raise the Kwik Cut high enough so that the disc can not come in contact with the ground during travel. Ensure the operator has a clear vision of the path ahead.

Select a safe ground travel speed when transporting from one area to another. Reduce ground speed when turning.

Hauling

When transporting the Kwik Cut on a trailer or on a truck, make sure the machine is properly and safely tied down and secure.



WARNING: Failure to secure the Kwik Cut when transporting could result in serious injury or death to surrounding.



General Maintenance

IMPORTANT: Refer to “Maintenance Safety” on page 7 and become familiar with the safety rules before performing any maintenance or service on the Kwik Cut.

To ensure efficient operation, you should inspect, lubricate, and make necessary adjustments and repairs at regular intervals. Parts that are starting to show wear should be ordered ahead of time, before a costly breakdown occurs and you have to wait for replacement parts. Keep good maintenance records, and adequately clean your brush cutter after each use.

Proper lubrication is important. Too little lubricant will cause premature failure of a bearing. Too much lubrication usually causes high operating temperature and early failure of seals. Follow all lubrication instructions and schedules included in this section.

Break-In Schedule

Inspect and service after one (1) hour of operation all bolts, teeth, and motor mount.

Regular maintenance should then be followed thereafter. Refer to the chart below for the maintenance schedule.

Maintenance Schedule

INTERVAL	SERVICE POINTS	SERVICE REQUIRED				
		CHECK	CLEAN	CHANGE	GREASE	ADJUST
Every 8 hr.	Machine		X			
	Loose Bolts					X
	Hoses	X				
	Oil Leaks	X				
	Blades and Teeth	X				
Every 100 hr.	Safety Labels	X				
Yearly	Bearing Support Lube			X		

Lubrication

Changing Bearing Support Gear Lube

IMPORTANT: The Kwik Cut must be disconnected from the power unit and the entire machine turned on its side for this procedure.

Refer to “Lifting Points” on page 23 for instructions on where to safely connect lifting equipment to the Kwik Cut.



DANGER: Crushing Hazard. Failure to safely secure and lift the Kwik Cut could result in severe injury or death. Use a power hoist and proper lifting equipment. Allow only trained personnel to lift the Kwik Cut.



Using the hoist and chains (or straps), lift and place the Kwik Cut on its side (shown above on left side). Make sure it is stable and secure for this procedure.

NOTE: The hoist/lifting device and chains or strap must be in good condition and of adequate size to lift the Kwik Cut.

The motor cover must be removed to access the bearing support ports. Refer to “Removing Motor Cover” on page 22 for instructions.

(Procedure continued on following page.)

Maintenance

Lubrication (Cont'd)

Changing Bearing Support Gear Lube (Cont'd)

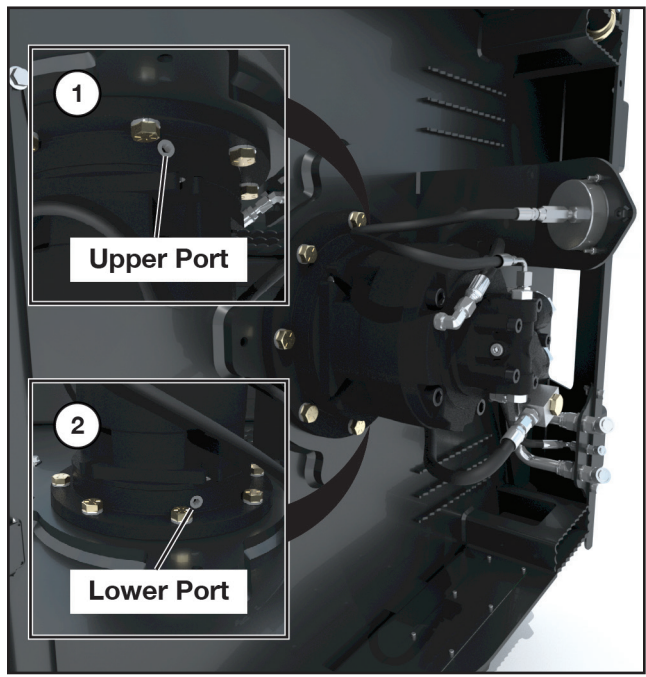

With the Kwik Cut on its side, use a 6 mm Allen wrench to remove the plug from the uppermost port (1) on the bearing support.

Place a container underneath the lowermost port (2) on the bearing support - large enough to hold 40 oz. of fluid, then remove the plug from that port using the 6 mm wrench.

Allow the fluid to drain completely. Reinsert the plug into the lowermost (2) port and tighten.

Add 40 oz. of 80W-90 gear lube (Mobil SHC 632 recommended) through the upper port (1).

When complete, reinsert the plug into the uppermost port and tighten.

Using the hoist, return the Kwik Cut back into the upright position, resting on the skids.

Disconnect the lifting equipment and reinstall the motor cover.

Removing Motor Cover

 **DANGER:** Shut down power from the power unit before removing the motor cover.

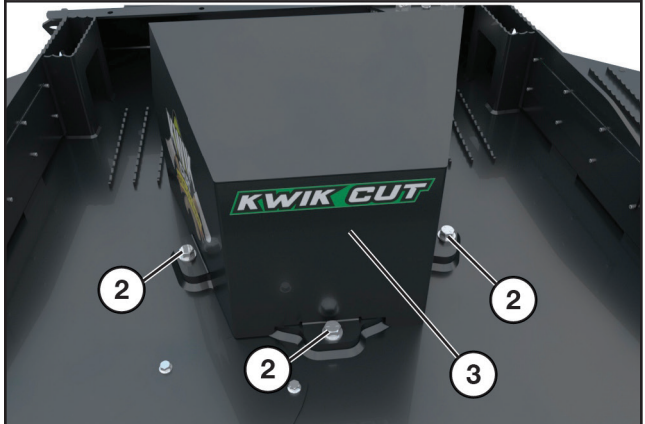
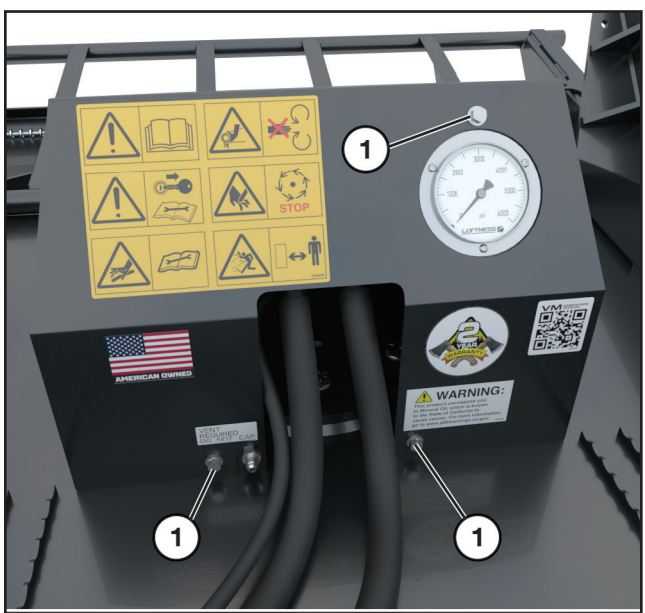

Using a 9/16" wrench remove the three 3/8" bolts (1). Then using an 15/16" wrench, remove the three 5/8" bolts (2). Slowly lift the motor cover (3) off of the frame.

IMPORTANT: The hose from the hydraulic motor to the back side of the pressure gauge will remain connected. Use care when removing the cover to prevent damage to the hose.

Reverse the procedure to return the cover back into position.

Reinstall the bolts and tighten.

Lifting Points



DANGER: Use only the designated lifting points when lifting the Kwik Cut. Lifting from any other location on the brush cutter could result in machine damage, severe injury or death.



Six lifting points are located on the Kwik Cut (three on each side of the machine). The decal shown above is located adjacent to each point.

IMPORTANT: Any hoist/lifting device, hooks, chains or straps must be in good condition and of adequate size to safely lift the Kwik Cut.



DANGER: Crushing Hazard. Failure to safely secure and lift the Kwik Cut could result in severe injury or death. Use a power hoist and proper lifting equipment. Allow only trained personnel to lift the Kwik Cut.

Disc Removal

IMPORTANT: The Kwik Cut must be disconnected from the power unit and the entire machine lifted and overturned for this procedure.

Refer to “Lifting Points” on page 23 for instructions on where to safely connect lifting equipment to the Kwik Cut.



DANGER: Crushing Hazard. Failure to safely secure and lift the Kwik Cut could result in severe injury or death. Use a power hoist and proper lifting equipment. Allow only trained personnel to lift the Kwik Cut.

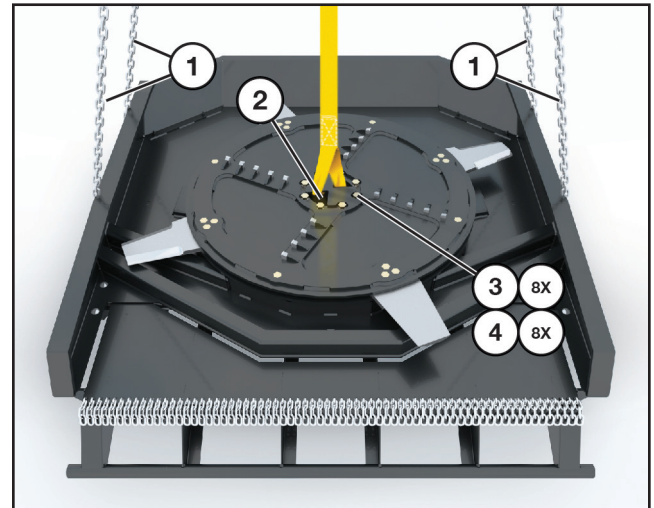

Use the hoist and chains (or straps) (1) to lift and overturn the Kwik Cut as shown, making sure it is stable and secure for this procedure.

NOTE: The hoist/lifting device and chains or strap must be in good condition and of adequate size to lift the Kwik Cut.



CAUTION: The blades and teeth on the disc are sharp. Wear gloves during this procedure to avoid getting cut while handling the disc.

Secure a chain or strap through the openings (2) on the disc.

Use a 1-1/8" socket to remove the eight bolts (3) with washers (4) securing the disc to the drive.

Using the hoist, slowly lift the disc. Hold onto the disc to maintain balance. DO NOT hold onto a blade or any of the teeth.

Reverse the process to reinstall the disc.

When reinstalling the bolts, apply red Loctite® to the bolt threads and into the threaded holes in the bearing support. Torque to 240 ft.-lbs.

Maintenance

Motor Removal

To remove the motor, the cutting disc must be removed first. Follow the procedure "Disc Removal" on page 23 to remove the disc.

When disc removal is complete, return the Kwik Cut back to the upright position before starting the motor removal procedure.

	DANGER: Disconnect the Kwik Cut from the loader to ensure that all power is cut off before starting this procedure.
---	--

Remove the motor cover. See "Removing Motor Cover" on page 22 for location and removal instructions.

Disconnect all hydraulic hoses connected at the motor.

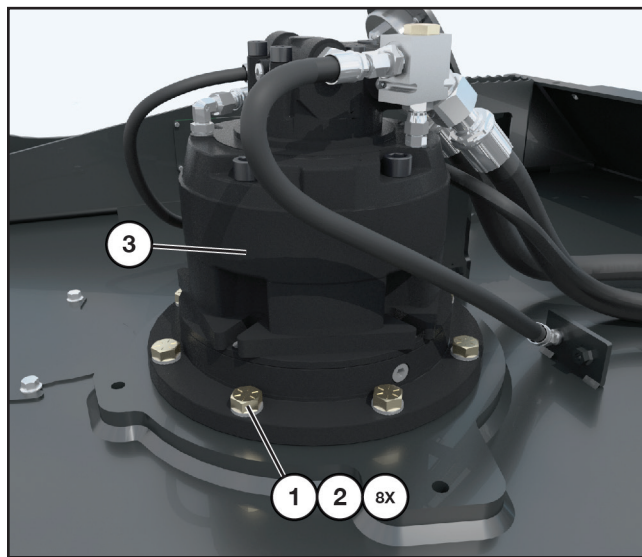

Using a 15/16" wrench, remove the eight bolts (1) and washers (2) securing the motor (3) to the motor mount.

	CAUTION: The motor is heavy. Use two people or a hoist to lift and remove the motor.
---	---

Pull motor up to remove from mount.

Reverse procedure to return motor back into operation.

When reinstalling the bolts, apply red Loctite® to the bolt threads and into the threaded holes in the disc. Torque to 165 ft.-lbs.

Blade and Tooth Access Plate

	DANGER: Shut down the power and disconnect the hydraulic supply from the loader before opening the access plate.
---	---

The access plate located on the top of the Kwik Cut frame provides access to the disc blades and teeth when service or maintenance is required.

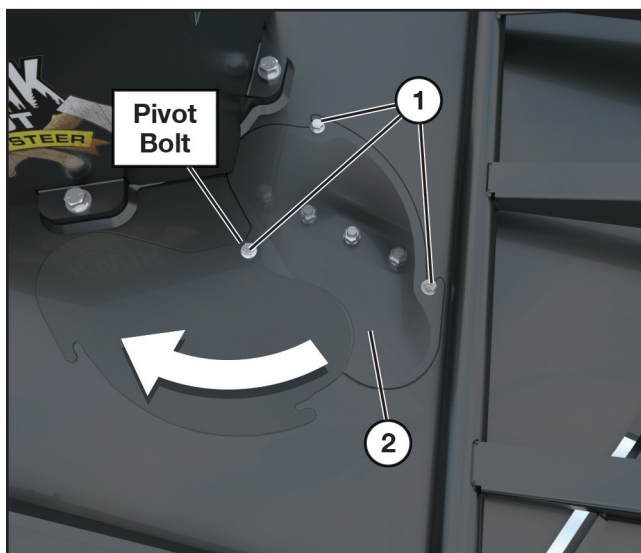

With a 9/16" wrench, loosen, but do not remove the three bolts (1) securing the plate (2) to the brush cutter frame.

Rotate the plate clockwise on the pivot bolt to access the disc blade and tooth hardware.

Reverse the procedure to return the cover back into position.

Tighten all bolts.

Blade and Tooth Removal/ Replacement

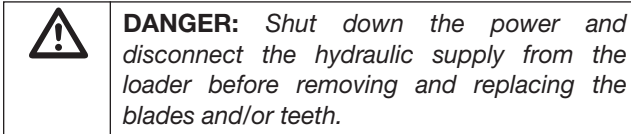

Open the access plate on top of the Kwik Cut deck. See “Blade and Tooth Access Plate” on page 24 for location and instructions.

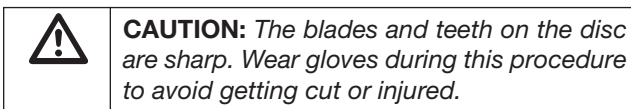

NOTE: The disc must be stabilized to remove the blades and teeth.

Cutting Blade

Rotate the cutting disc until the hardware securing the blade is visible through the access door.

The bolt head on the opposite side of the disc is set into the disc plate. Place a rag or pan underneath the blade to catch the bolt as the nut is removed.

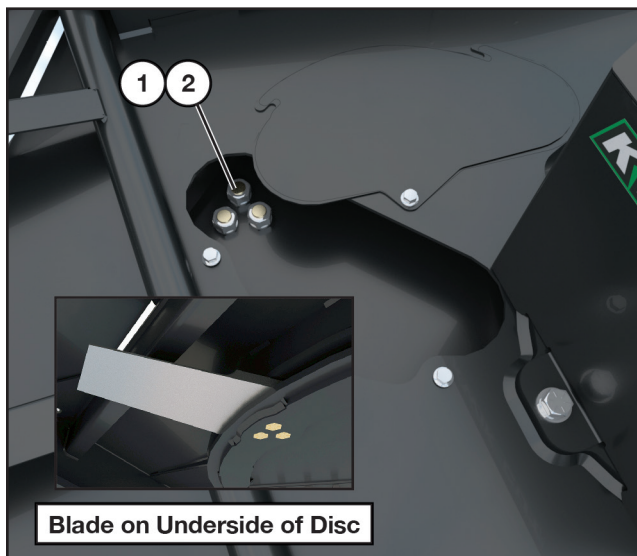

Using a 1-1/8" socket, remove the three nuts (1) with washers (2). The bolts from the underside will drop through.

From the front of the Kwik Cut, reach under and remove the blade with the spacer, making note of the orientation of the cutting edge (edge up, or edge down). The new blade must be returned in the same orientation. If needed, refer to the exploded view on page 34 for assembly.

When reinstalling the blade, apply red Loctite® to the bolt threads. Torque the nuts to 240 ft.-lbs.

IMPORTANT: When a damaged blade is replaced, the blade directly opposite (180 degrees) must be replaced at the same time to retain balance.

Blade Rotation

When the blades are getting noticeably dull, remove and flip each of the four blades 180° to provide a fresh cutting edge.

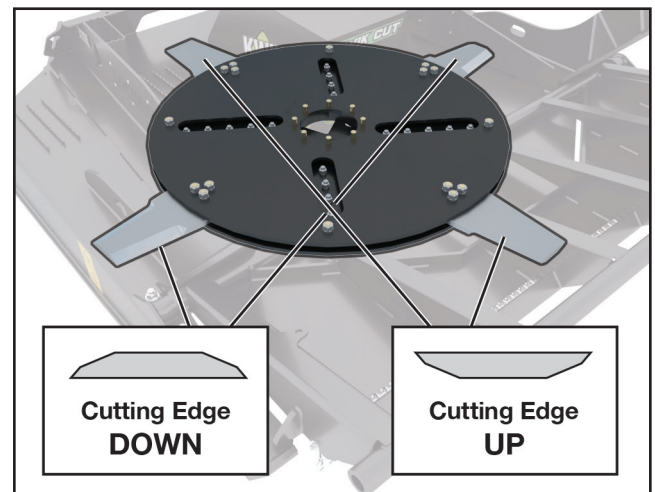

IMPORTANT: The cutting blades must be installed maintaining an alternating orientation on the disc as shown above.

Damaged or dull blades should be replaced.

Maintenance

Blade and Tooth Removal/ Replacement (Cont'd)

Cutting Teeth

Rotate the cutting disc until the hardware securing the set of teeth are visible through the access door.

Place a rag or pan underneath the disc to catch the tooth as the nut and washer are removed.

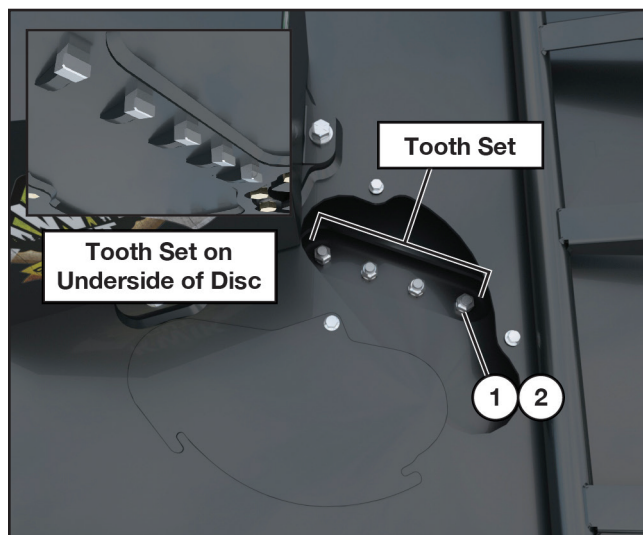

Using a 15/16" socket, remove the nut (1) and washer (2). When removed, the tooth on the underside of the disc will drop through.

From the front of the Kwik Cut, reach under and collect the tooth.

Follow this process to remove all teeth.

When reinstalling the tooth, apply red Loctite® to the threads. Torque to 128 ft.-lbs. when reinstalling the nuts.

IMPORTANT: *Damaged or dull teeth should be replaced. Do not sharpen the teeth.*

Storage

End of Season

- Clean entire Kwik Cut thoroughly.
- Change lube in the bearing support. See “Changing Bearing Support Gear Lube” on page 21.
- Make a list of all worn or damaged parts and replace them.
- Paint all parts that are worn or rusted.
- Store brush cutter in a clean, dry area.
- Review the brush cutter operator’s manual.
- Secure hydraulic hoses in storage position. See “Hydraulic Hose Storage” on page 19.

Beginning of the Season

- Review the Kwik Cut operator’s manual.
- Tighten all bolts, nuts, and set screws. See “Torque Specifications” on page 45.
- Replace all damaged, worn or missing decals.
- Install the brush cutter on a loader and test for proper operation.

GPM Chart

Radial Piston Motor 5000 PSI

GPM	Disc RPM	Piston Motor Number	Displacement	Loftness Part number
28	707	5	150 Max Displacement	SAI 209767
29	732			
30	757			
31	782			
32	808			
33	833			
34	858			
35	883			
36	908			
37	934			
38	959			
39	984			
40	1009			
41	1035			
42	1060			
43	1085			
44	1110			
45	1136			

Maintenance

Troubleshooting

PROBLEM	CAUSE	SOLUTION
Excessive Vibration	Broken or missing tooth or blade.	Replace teeth or blade.
	Mud and/or debris wrapped around the disc.	Clean the brush cutter.
	Damage to disc (includes bent spindle or actual disc deformity from striking rocks, etc.)	Consult factory.
Uneven Cutting	Teeth and/or blades are dull or worn excessively.	Replace teeth and/or blades.
	Engine RPM too slow.	Adjust machine RPM to full throttle.
	Travel speed too fast.	Reduce ground speed.
Disc Will Not Turn	Low oil.	Check oil level in loader. Add if necessary.
	Low oil flow.	Check flow control on loader.
	Oil filter plugged.	Replace loader oil filter.
	Disc jammed.	Remove material from disc.
	Quick couplers at loader are installed incorrectly.	Check hose connections.
Oil Leak At Hydraulic Control Valve Cover.	Pinched case drain hose.	Check hose.
	Disconnected case drain hose.	Reconnect hose.



PARTS IDENTIFICATION

Parts Identification

Cutter Door; Skid Plates; Access Plate

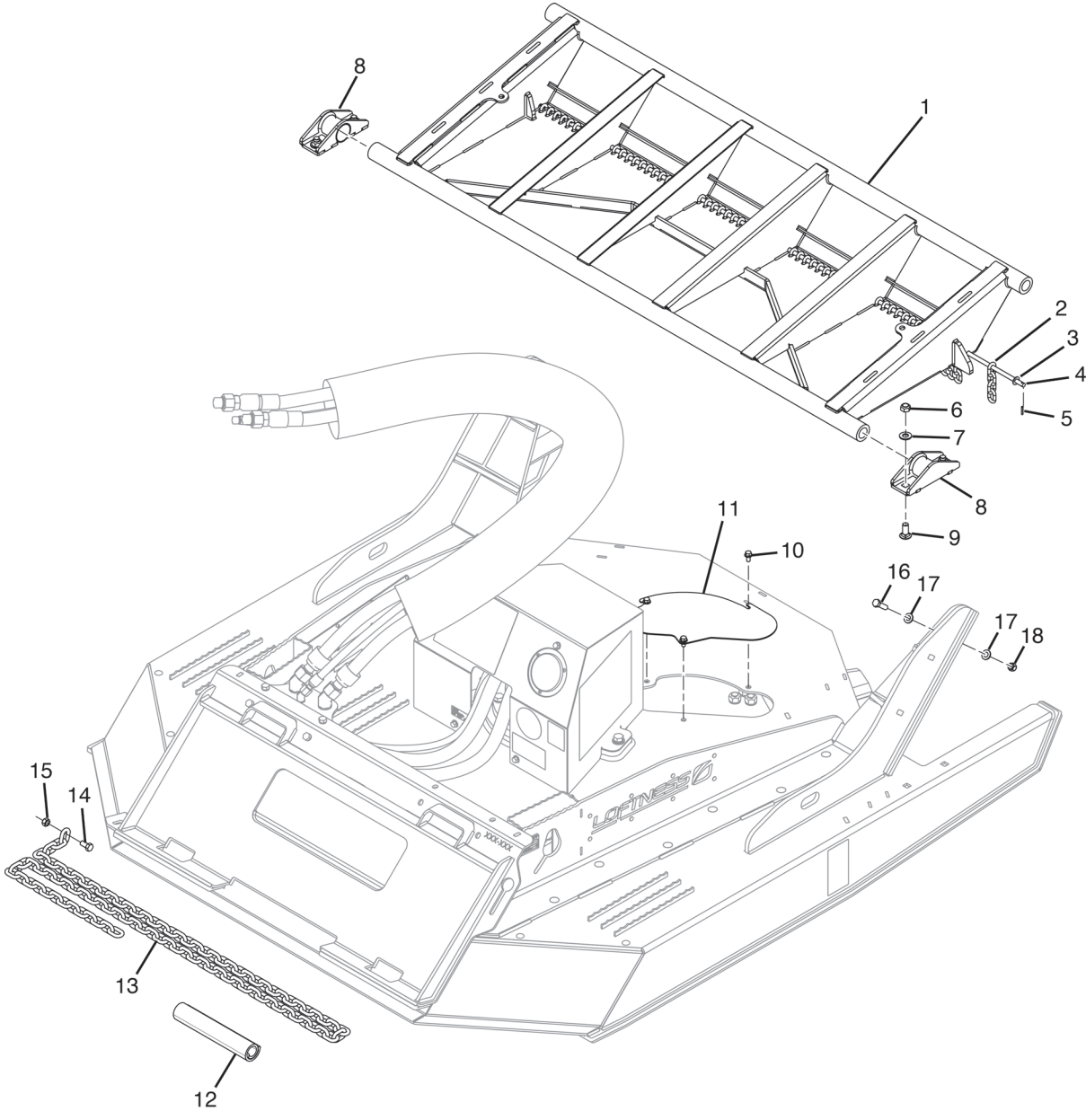

Parts Identification

Cutter Door; Skid Plates; Access Plate

#	QTY.	PART #	DESCRIPTION
1	1	201887	DOOR, ROTARY CUTTER 2
2	68	201519	CHAIN, 5/16 DEFLECTOR 4 LINK
3	2	4301	WASHER, 7/16" FLAT
4	1	201490	ROD, ROTARY CUTTER 72" CHAIN
5	2	4375	PIN, ROLL 3/16" X 1"
6	4	4055	NUT, LOCK 5/8" TOP
7	4	4997	WASHER, FLAT 5/8" SAE
8	2	217029	HINGE, KWIK CUT DOOR 5/8
9	4	4386	BOLT, CARRIAGE 5/8" X 1-1/2"
10	3	N36497	BOLT, 3/8" X 3/4" SER FLG
11	1	201457	PLATE, TOOTH ACCESS
12	1	201480	MANUAL, ROTARY CUTTER
13	1	215643	CHAIN, 3/8 X 10' GRADE 70
14	1	N15717	BOLT, 1/2" X 1" GR 8 FINE THRD
15	1	4436	NUT, 1/2" LOCK FN TD GRADE 8
16	2	4014	BOLT, 1/2" X 1-3/4" GRADE 5
17	4	4068	WASHER, 1/2" SAE FLAT
18	2	N149702	NUT, LOCK 1/2-13 NYLOCK

Parts Identification

Drive Motor; Motor Cover; Cutter

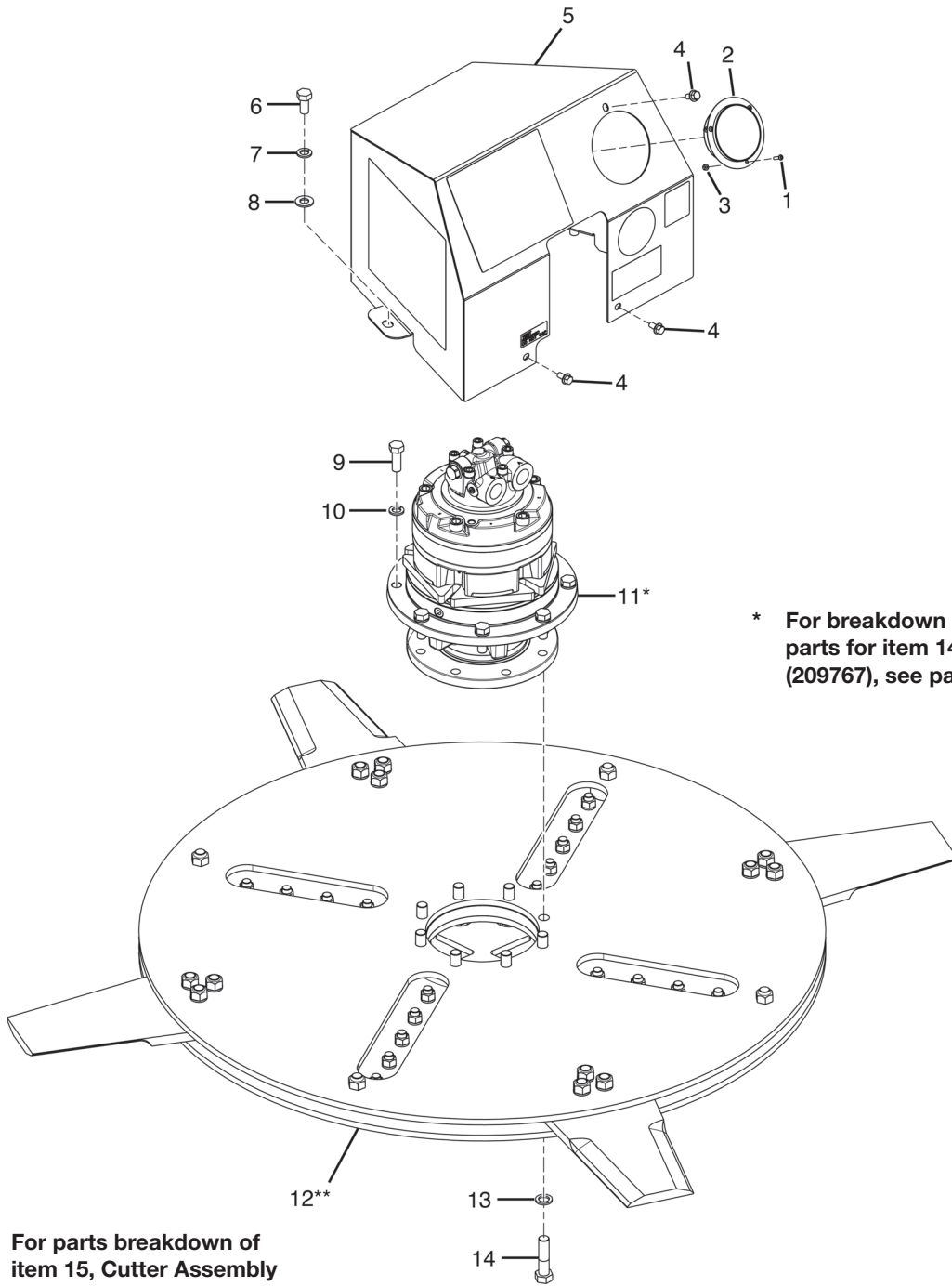

* For breakdown of replacement parts for item 14, SAI motor (209767), see page 38.

** For parts breakdown of item 15, Cutter Assembly (201430), see page 34.

Parts Identification

Drive Motor; Motor Cover; Cutter

#	QTY.	PART #	DESCRIPTION
1	3	N22358	BOLT, #10-32 X 3/4" BHCS
2	1	205041	GAUGE, 0-6000 PSI 4IN PRESS
3	3	N16334	NUT, NYLON INSERT #10
4	3	N36497	BOLT, 3/8" X 3/4" SER FLG
5	1	217390	COVER, MOTOR W/DECALS
6	3	4019	BOLT, 5/8" X 1-1/4" GRADE 5
7	3	4070	WASHER, LOCK 5/8"
8	3	4997	WASHER, FLAT 5/8" SAE
9	8	N16476	BOLT, 5/8"-11 X 1-3/4" GR 8
10	8	N16473	WASHER, NORD-LOCK 5/8 IN
11	1	209767	MOTOR, 150CC SAI SAE PORTS
12	1	201430	ASSEMBLY, CUTTER
13	8	N16474	WASHER, 3/4 NORDLOCK
14	8	201481	BOLT, 3/4"-10 X 3" GRADE 8

Parts Identification

Cutter Assembly (201430)

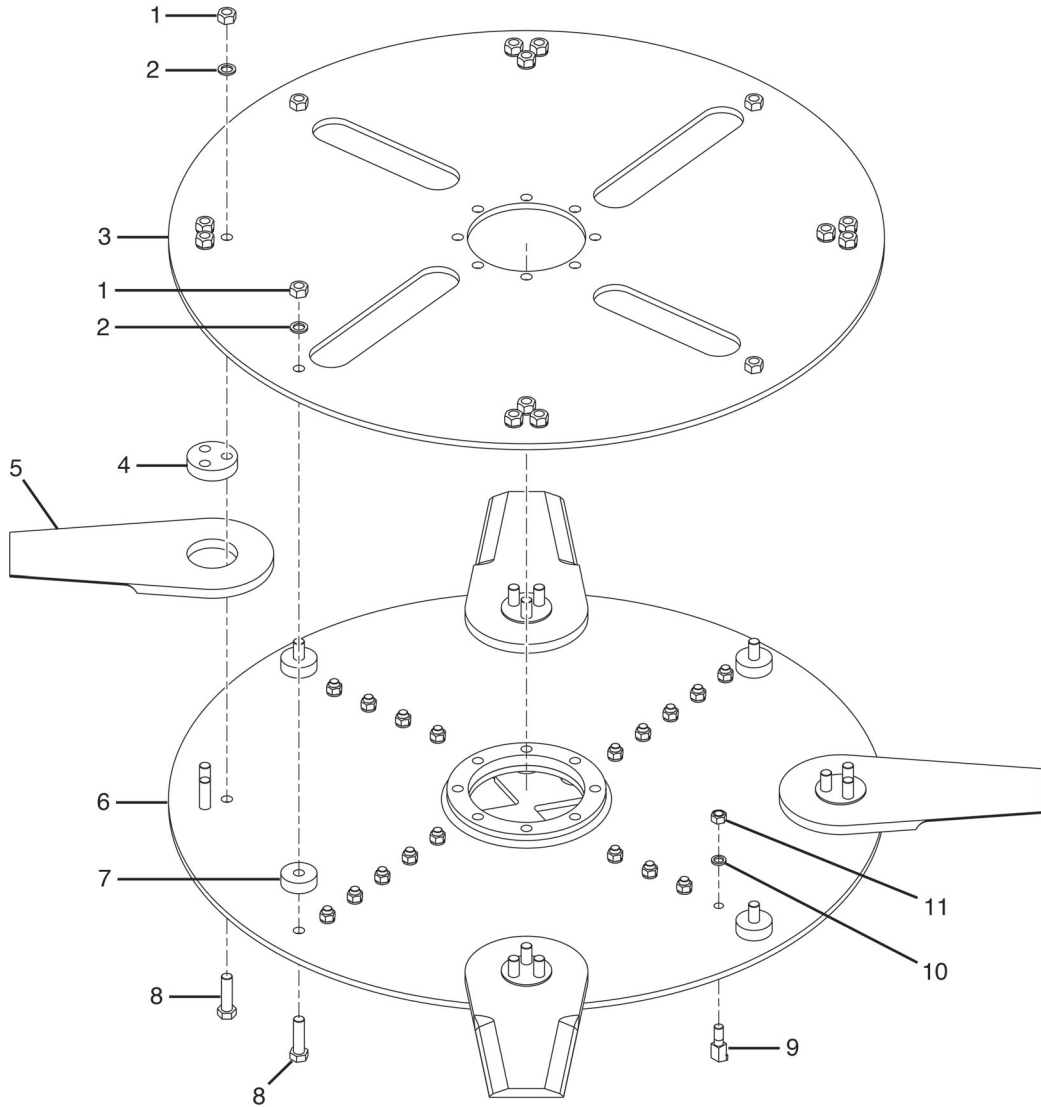

Parts Identification

Cutter Assembly (201430)

#	QTY.	PART #	DESCRIPTION
1	16	N16352	NUT, LOCK 3/4" GRADE 8 FINE
2	16	N16474	WASHER, 3/4 NORDLOCK
3	1	201423	PLATE, UPPER BLADE MOUNT
4	4	201426	PLATE, BLADE SPACER
5	4	201428	BLADE, DUAL EDGE
6	1	201429	WELDMENT, BLADE HOLDER
7	4	201425	PLATE, MOUNT SPACER
8	16	N16510	BOLT, 3/4" X 2-3/4" FN TH GR8
9	18	201433	TOOTH, 5/8" UNF STUMP CUTTER
10	18	N16473	WASHER, 5/8 NORDLOCK
11	18	4057	NUT, 5/8" FINE THREAD TOP LOCK

Parts Identification

Hydraulics

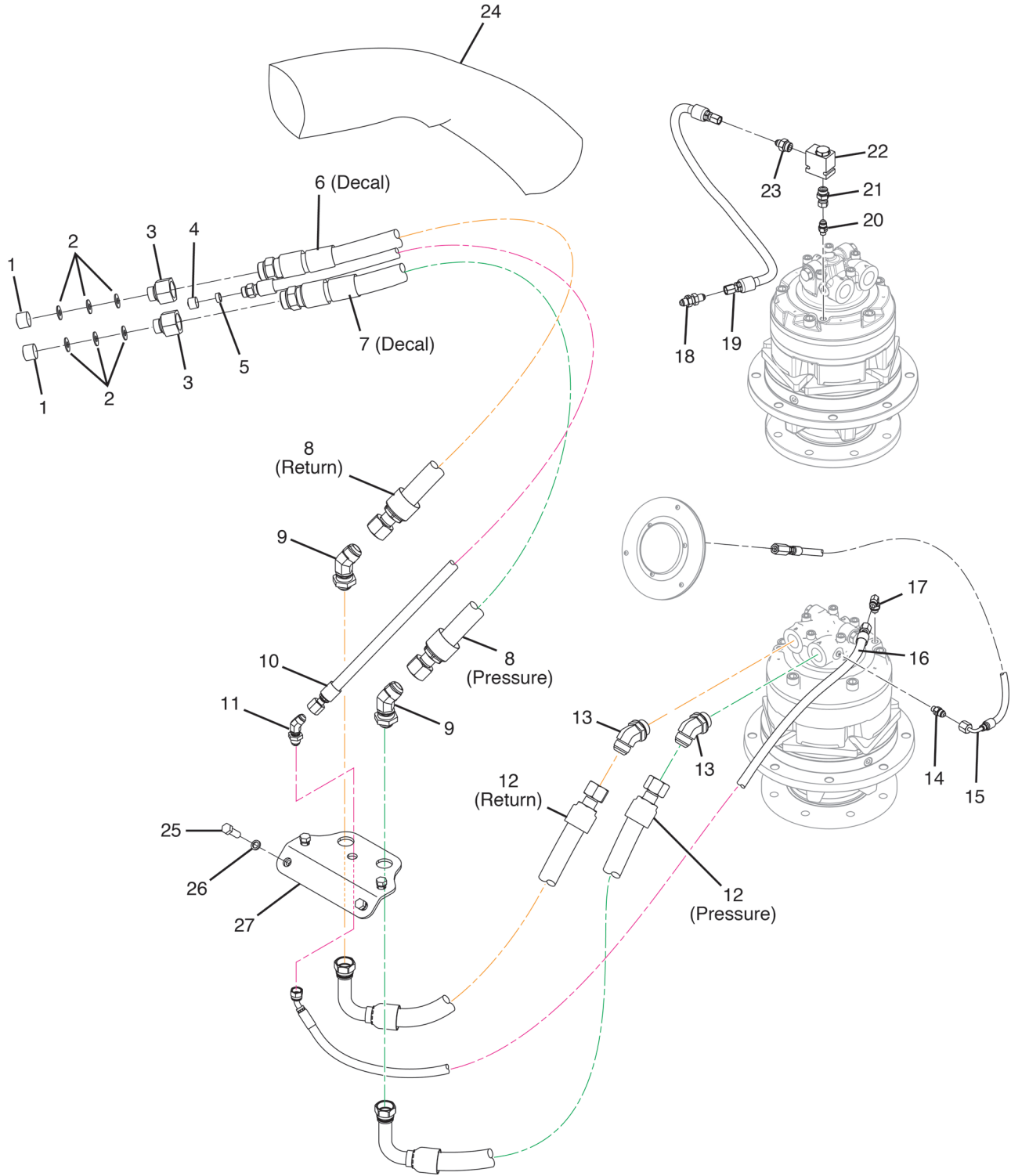

Parts Identification

Hydraulics

#	QTY.	PART #	DESCRIPTION
1	2	N15893	CAP, 3/4 ALUMINUM HOSE
2	6	4064	WASHER, FLAT 3/8"
3	2	N28108	ADAPTER, - 12MOR - 16FOR
4	1	N15895	CAP, 1/2 ALUMINUM HOSE
5	1	N32002	PLUG, 3/8 SCH 40 X .25
6	1	N24823	DECAL, RETURN
7	1	N24822	DECAL, PRESSURE
8	2	N90130	HOSE, 1 84 -16FJIC -16MORB
9	2	N108294	ADAPTER, BULKHEAD 45-16MJIC
10	1	N34579	HOSE, 1/2 84 -8FJIC -8MORB
11	1	200382	ADAPTER, 45 BULKHEAD -8MJIC
12	2	209994	HOSE, 1 X 32.00 -16FJIC-16FJIC90LG
13	2	N19273	ELBOW 45 DEG, 16MJIC - 16MOR
14	1	N28824	ADAPTER, 6MJIC -4MOR
15	1	201539	HOSE, 1/4 X 26 -4FPSW -6FJIC90
16	1	209992	HOSE, 3/8 X 45.00 -6FJX-8FJX45
17	1	201526	ELBOW, 90 DEG -6MJIC -4MBSPP
18	1	207832	ADAPTER, 45 BULKHEAD -6MJIC
19	1	206509	HOSE, 3/8 X 23 -6FJIC -6FJIC, 3000PSI
20	1	N28846	ADAPTER, -6MJIC -4MBSPP
21	1	207880	ADAPTER, -8MOR -6FJIC
22	1	214076	VALVE, RELIEF 200PSI
23	1	N17022	ADAPTER, 6MJIC - 8MOR
24	1	N88334	WRAP, HOSE 70
25	4	4012	BOLT, 1/2" X 1-1/4" GRADE 5
26	4	N16472	N16472 WASHER, 1/2 NORDLOCK
27	1	215809	BRACKET, BULKHEAD MOUNTING

Parts Identification

SAI Motor (209767)

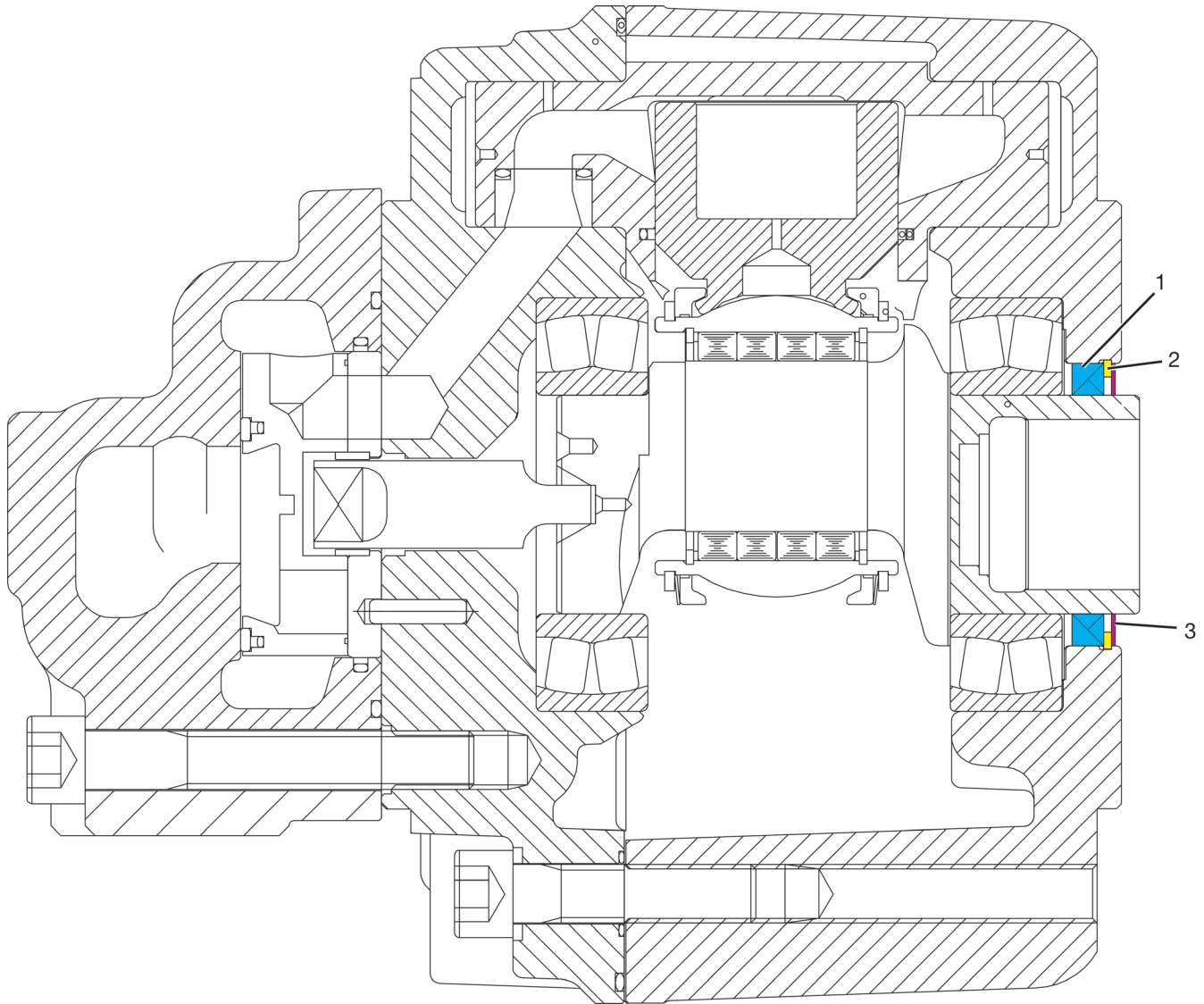

#	QTY.	PART #	DESCRIPTION
*	1	206999	KIT, FS30A1/A2 MOTOR SEAL (Includes items 1, 2 and 3)
1	1	NOT SOLD SEPARATELY	SEAL, SHAFT
2	1	NOT SOLD SEPARATELY	RING, RETAINING SB70
3	1	NOT SOLD SEPARATELY	RING, HIGH PRESSURE BACKUP

Seal, SAI Bearing Support Shaft (212126)

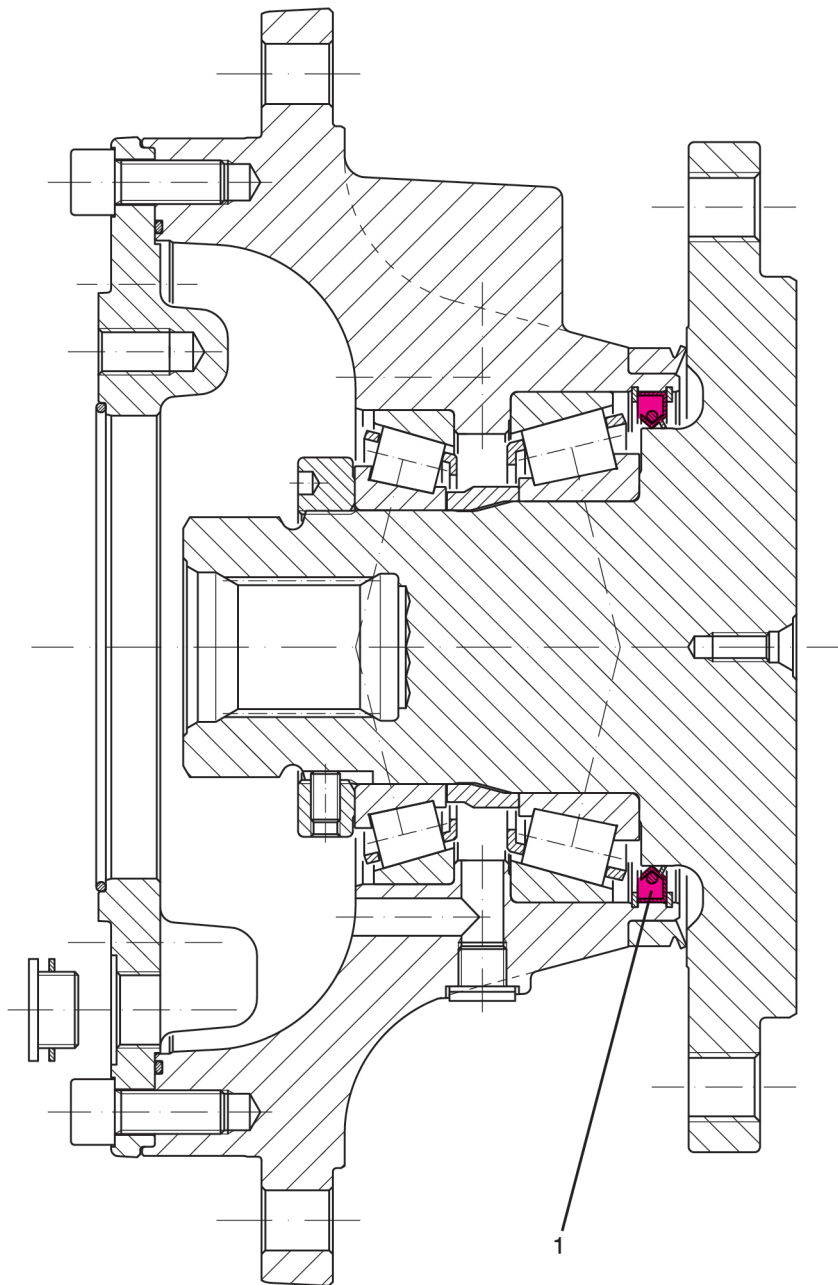

#	QTY.	PART #	DESCRIPTION
1	1	212126	SEAL, SAI BEARING SUPPORT SHAFT

Parts Identification

Machine Decals and Signs

NOTE: All safety related decals are also shown in the Safety Instructions Section along with their location on the machine. See "Safety Decals" on page 10.

Check and replace any worn, torn, hard to read or missing decals on your machine.

Part No. 216436



Part No. 216437



Part No. 203264



Part No. 214428

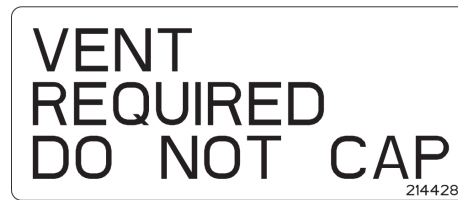

Part No. N24823



Part No. N24822

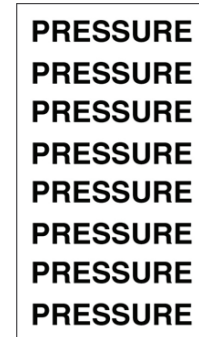

Machine Decals and Signs (Cont'd)

Part No. N13721

LOFTNESS 			
Model			
Serial Number			
Net Weight	Lb	Max Flow	Gpm
Max Power	Hp	Max Pressure	Psi

Part No. 209449



Part No. 214438



Part No. 217394





Specifications

DESCRIPTION	KWIK CUT
Cutting Width	72 in. (183.9 cm)
Capacity Monitor	Pressure Gauge
Motor	Radial Piston - 150cc
Mount	Universal Skid Type
Cutters	4 Dual-Edge Beveled Blades; 18 Carbide Cutting Teeth on Underside of Disc
Skid Shoes	Abrasive resistant
Deflector	Chains

Appendix

Dimensions

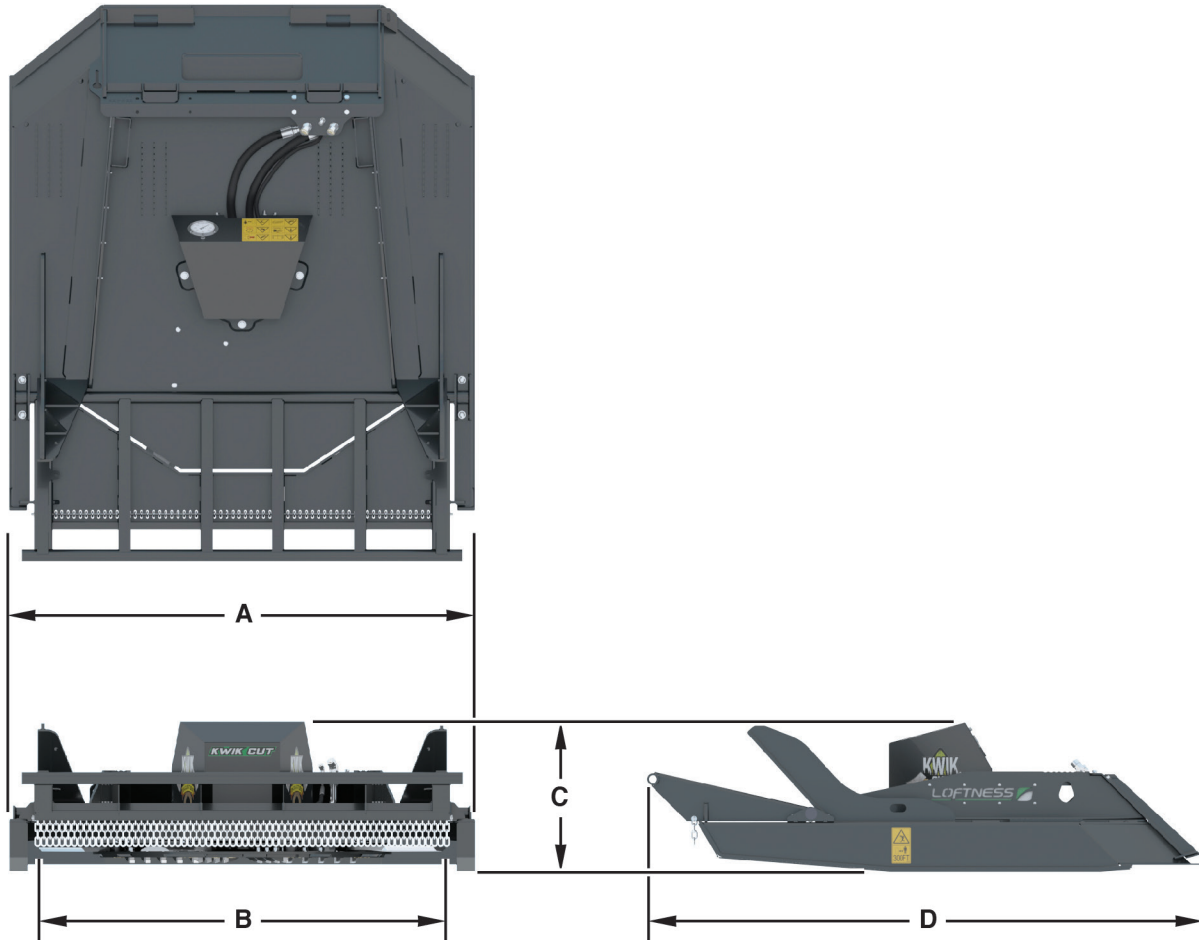

DESCRIPTION	Kwik Cut
Overall Width (A)	78 in. (198.1 cm)
Cutting Width (B)	72 in. (183.9 cm)
Operating Height (C)	25 in. (63.5 cm)
Overall Length (D)	92 in. (233.7 cm)
Cutters	4 Dual-Edge Beveled Blades; 18 Carbide Cutting Teeth on Underside of Disc
Weight	2,350 lbs. (1066 kg)
Crated Weight	2,500 lbs. (1134 kg)

Torque Specifications

Inches Hardware and Lock Nuts

TORQUE CHARTS

Minimum Hardware Tightening Torques

Normal Assembly Applications
(Standard Hardware and Lock Nuts)

SAE Gr. 2 Nominal Size	SAE Grade 5		SAE Grade 8		LOCK NUTS			
	Unplated or Plated Silver	Plated W / ZnCr Gold	Unplated or Plated Silver	Plated W / ZnCr Gold	Unplated or Plated Silver	Plated W / ZnCr Gold	Grade W / Gr. 5 Bolt	Grade W / Gr. 8 Bolt
1/4	55 in.-lb. (6.2 N•m)	72 in.-lb. (8.1 N•m)	86 in.-lb. (9.7 N•m)	112 in.-lb. (12.6 N•m)	121 in.-lb. (13.6 N•m)	157 in.-lb. (17.7 N•m)	61 in.-lb. (6.9 N•m)	86 in.-lb. (9.8 N•m)
5/16	115 in.-lb. (13 N•m)	149 in.-lb. (17 N•m)	178 in.-lb. (20 N•m)	229 in.-lb. (26 N•m)	250 in.-lb. (28 N•m)	324 in.-lb. (37 N•m)	125 in.-lb. (14 N•m)	176 in.-lb. (20 N•m)
3/8	17 ft.-lb. (23 N•m)	22 ft.-lb. (30 N•m)	26 ft.-lb. (35 N•m)	34 ft.-lb. (46 N•m)	37 ft.-lb. (50 N•m)	48 ft.-lb. (65 N•m)	19 ft.-lb. (26 N•m)	26 ft.-lb. (35 N•m)
7/16	27 ft.-lb. (37 N•m)	35 ft.-lb. (47 N•m)	42 ft.-lb. (57 N•m)	54 ft.-lb. (73 N•m)	59 ft.-lb. (80 N•m)	77 ft.-lb. (104 N•m)	30 ft.-lb. (41 N•m)	42 ft.-lb. (57 N•m)
1/2	42 ft.-lb. (57 N•m)	54 ft.-lb. (73 N•m)	64 ft.-lb. (87 N•m)	83 ft.-lb. (113 N•m)	91 ft.-lb. (123 N•m)	117 ft.-lb. (159 N•m)	45 ft.-lb. (61 N•m)	64 ft.-lb. (88 N•m)
9/16	60 ft.-lb. (81 N•m)	77 ft.-lb. (104 N•m)	92 ft.-lb. (125 N•m)	120 ft.-lb. (163 N•m)	130 ft.-lb. (176 N•m)	169 ft.-lb. (229 N•m)	65 ft.-lb. (88 N•m)	92 ft.-lb. (125 N•m)
5/8	83 ft.-lb. (112 N•m)	107 ft.-lb. (145 N•m)	128 ft.-lb. (174 N•m)	165 ft.-lb. (224 N•m)	180 ft.-lb. (244 N•m)	233 ft.-lb. (316 N•m)	90 ft.-lb. (122 N•m)	127 ft.-lb. (172 N•m)
3/4	146 ft.-lb. (198 N•m)	189 ft.-lb. (256 N•m)	226 ft.-lb. (306 N•m)	293 ft.-lb. (397 N•m)	319 ft.-lb. (432 N•m)	413 ft.-lb. (560 N•m)	160 ft.-lb. (217 N•m)	226 ft.-lb. (306 N•m)
7/8	142 ft.-lb. (193 N•m)	183 ft.-lb. (248 N•m)	365 ft.-lb. (495 N•m)	473 ft.-lb. (641 N•m)	515 ft.-lb. (698 N•m)	667 ft.-lb. (904 N•m)	258 ft.-lb. (350 N•m)	364 ft.-lb. (494 N•m)
1	213 ft.-lb. (289 N•m)	275 ft.-lb. (373 N•m)	547 ft.-lb. (742 N•m)	708 ft.-lb. (960 N•m)	773 ft.-lb. (1048 N•m)	1000 ft.-lb. (1356 N•m)	386 ft.-lb. (523 N•m)	545 ft.-lb. (739 N•m)

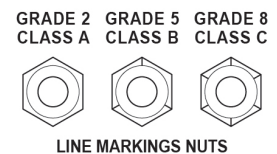
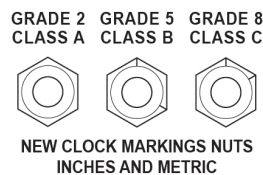
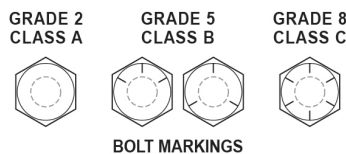

Appendix

Torque Specifications (Cont'd)

Metric Hardware and Lock Nuts

TORQUE CHARTS

Minimum Hardware Tightening Torques

Normal Assembly Applications
(Metric Hardware and Lock Nuts)

Nominal Size	Class 5,8		Class 8,8		Class 10,9		Lock nuts Class 8 W / CL. 8,8 Bolt
	Unplated or Plated Silver	Plated W / ZnCr Gold	Unplated or Plated Silver	Plated W / ZnCr Gold	Unplated or Plated Silver	Plated W / ZnCr Gold	
M4	1.7 N•m (15 in.-lb.)	2.2 N•m (19 in.-lb.)	2.6 N•m (23 in.-lb.)	3.4 N•m (30 in.-lb.)	3.7 N•m (33 in.-lb.)	4.8 N•m (42 in.-lb.)	1.8 N•m (16 in.-lb.)
M6	5.8 N•m (51 in.-lb.)	7.6 N•m (67 in.-lb.)	8.9 N•m (79 in.-lb.)	12 N•m (102 in.-lb.)	13 N•m (115 in.-lb.)	17 N•m (150 in.-lb.)	6.3 N•m (56 in.-lb.)
M8	14 N•m (124 in.-lb.)	18 N•m (159 in.-lb.)	22 N•m (195 in.-lb.)	28 N•m (248 in.-lb.)	31 N•m (274 in.-lb.)	40 N•m (354 in.-lb.)	15 N•m (133 in.-lb.)
M10	28 N•m (21 ft.-lb.)	36 N•m (27 ft.-lb.)	43 N•m (32 ft.-lb.)	56 N•m (41 ft.-lb.)	61 N•m (45 ft.-lb.)	79 N•m (58 ft.-lb.)	30 N•m (22 ft.-lb.)
M12	49 N•m (36 ft.-lb.)	63 N•m (46 ft.-lb.)	75 N•m (55 ft.-lb.)	97 N•m (72 ft.-lb.)	107 N•m (79 ft.-lb.)	138 N•m (102 ft.-lb.)	53 N•m (39 ft.-lb.)
M16	121 N•m (89 ft.-lb.)	158 N•m (117 ft.-lb.)	186 N•m (137 ft.-lb.)	240 N•m (177 ft.-lb.)	266 N•m (196 ft.-lb.)	344 N•m (254 ft.-lb.)	131 N•m (97 ft.-lb.)
M20	237 N•m (175 ft.-lb.)	307 N•m (226 ft.-lb.)	375 N•m (277 ft.-lb.)	485 N•m (358 ft.-lb.)	519 N•m (383 ft.-lb.)	671 N•m (495 ft.-lb.)	265 N•m (195 ft.-lb.)
M24	411 N•m (303 ft.-lb.)	531 N•m (392 ft.-lb.)	648 N•m (478 ft.-lb.)	839 N•m (619 ft.-lb.)	897 N•m (662 ft.-lb.)	1160 N•m (855 ft.-lb.)	458 N•m (338 ft.-lb.)

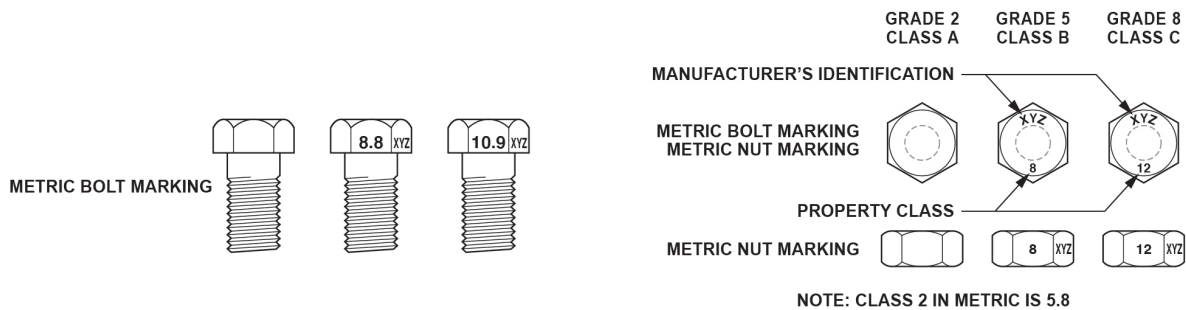



www.loftness.com

Loftness Specialized Equipment, Inc.
650 So. Main Street • PO Box 337 • Hector, MN 55342
Tel: 320.848.6266 • Fax: 320.848.6269 • Toll Free: 1.800.828.7624

Printed in USA
© Loftness 2026