



# Kubota SVL97-3/SVL110-3 Oil Cooler Cab Mount Kit

## Installation Instructions

(Originating with Oil Cooler  
Serial Number 50-1183)

Model Number: \_\_\_\_\_  
Serial Number: \_\_\_\_\_  
Date of Purchase: \_\_\_\_\_





# LOFTNESS SPECIALIZED EQUIPMENT, INC.

## LIMITED WARRANTY POLICY

The limited warranty policy begins upon delivery of the unit to the original customer.

The following Loftness products have a two (2) year limited warranty;

XLB10 Grain Bag Loader, Battle Ax L-series Skid Steer, Battle Ax S-series Skid Steer, Battle Ax H-series Skid Steer, Battle Ax Excavator 20-series, Battle Ax Excavator 30-series, Battle Ax Excavator 40-series, Battle Ax Excavator 50-series, Battle Ax Extreme, Bad Ax Skid Steer, Timber Ax Skid Steer, Stump Ax, BT20, Kwik Cut.

All other Loftness products have a one (1) year limited warranty.

If any Loftness product is used as rental or leased equipment the limited warranty period is for only 30 days from the delivery date to the original customers.

Loftness Specialized Equipment, Inc. (“LOFTNESS”) warrants new LOFTNESS machinery and/or attachments at the time of delivery to the original purchaser, to be free from defects in material and workmanship when properly set up and operated in accordance with the recommendations set forth in the LOFTNESS Operator’s Manual. The second year of limited warranty includes only parts, and not labor.

LOFTNESS’ liability for any defect with respect to accepted goods shall be limited to repairing the goods at an authorized dealer or other LOFTNESS designated location, or replacing them as LOFTNESS shall elect. The above shall be in accordance with LOFTNESS warranty adjustment policies.

### WARRANTY REQUIREMENTS

**Warranty registration form must be filled out and returned to Loftness Specialized Equipment to validate all warranty claims.**

To request a warranty claim, a return authorization from LOFTNESS must be obtained. The failed part may then be returned in an untampered status. This warranty does not include freight or delivery charges incurred when returning machinery for servicing. Dealer mileage, service calls and pick-up/delivery charges are the customer’s responsibility.

### LIMITATIONS OF WARRANTY

LOFTNESS products are designed to provide years of dependable service when proper use and maintenance is adhered to. The potential for misuse in many applications exists; therefore, a limited warranty is provided as follows.

This warranty shall not apply to any machine or attachment which shall have been repaired or altered outside the LOFTNESS factory or authorized LOFTNESS dealership or in any way so as in LOFTNESS’ judgment, to affect its stability or reliability, nor which has been subject to misuse, negligence or accident, nor to any machine or attachment which shall not have been operated in accordance with LOFTNESS’ printed instructions or beyond the company recommended machine rated capacity. LOFTNESS may elect to have an area representative evaluate the condition of the machine before warranty is considered.

In addition, this limited warranty provides no coverage for general wear or maintenance items, misuse, environmental conditions and/or contamination for which they were not designed or not intended, including but not limited to the following items;

Use of machine beyond its rated capacity, Conveyors, Improper knife replacement, Auger wear, Missing knives, Saw blades, Striking foreign objects, Brakes and brake pads, Lack of lubrication, Tires, Failures caused by running in an “out-of-balance” condition, Hydraulic hoses damaged by being caught in “pinch points” or by moving parts, and Damage caused by excessive force from the power unit.

### EXCLUSIONS OF WARRANTY

Except as otherwise expressly stated herein, LOFTNESS makes no representation or warranty of any kind, expressed or implied. **The implied warranty of merchantability and fitness for a particular purpose are disclaimed, and excluded from this limited warranty.** The remedies set forth in this warranty are the sole and exclusive remedies available to any person under this warranty. LOFTNESS shall have no liability to any person for incidental, consequential or special damages of any description, whether arising out of express or implied warranty or any other contract, negligence, or other tort or otherwise. This exclusion of consequential, incidental and special damages is independent from and shall survive any finding that the exclusive remedy failed of its essential purpose. Upon purchase, the buyer assumes all liability, all personal injury and property damage resulting from the handling, possession or use of the goods by the buyer.

No agent, employee or representative of LOFTNESS has any authority to bind LOFTNESS to any affirmation, representation or warranty concerning its machinery and/or attachments except as specifically set forth herein. (October 2025)

**LOFTNESS** ™

# Table of Contents

---

## Warranty

## Table of Contents

## Introduction

Dealer/Owner Information . . . . .	1
Dealer/Owner Responsibility . . . . .	1

## Safety Instructions

Safety First . . . . .	2
Safety Rules . . . . .	2
Set-up Safety . . . . .	2
Hoist (Lifting) Safety . . . . .	3
Hydraulic Safety . . . . .	3
California Proposition 65 Warning . . . . .	3

## Options

Universal Oil Cooler Kit (Kubota SVL97-3/SVL110-3) Options . . . . .	4
--	---

## Installation Instructions

Set-up . . . . .	6
Mounting the Oil Cooler to the Cooler Mounting Frame . . . . .	6
Mounting the Cooler Kit to the Cab . . . . .	6
Temporarily Removing the Front Lights . . . . .	6
Mounting . . . . .	7
Reinstalling the Front Lights . . . . .	8
Installing Hydraulic Hoses and Electrical Wiring Harness . . . . .	8
Removing Access Panel . . . . .	8
Drilling Routing Holes . . . . .	9
Draining Hydraulic Oil . . . . .	9
Disconnecting Kubota Loader Hoses . . . . .	10
Connecting and Routing Oil Cooler Kit Hoses . . . . .	11
Hose Connection - Control Valve/Oil Cooler Inlet (215895) . . . . .	11
Hose Connection - Hydraulic Tank/Oil Cooler Outlet (215893) . . . . .	12
Reconnecting Loader Hoses . . . . .	12
Refilling Hydraulic Tank . . . . .	13
Oil Cooler Hydraulic Connections . . . . .	13
Routing the Cooler Wiring Harness . . . . .	13
Loftness Cooler Position Schematic (Wire Harness N68127) . . . . .	15
Electrical Connections . . . . .	16
Check and Verify Fan Operation . . . . .	16
To Check Fan with Key On . . . . .	16
Securing Hoses and Wiring Harness . . . . .	16
Testing the Oil Cooler Cab Kit . . . . .	17
Securing Swing-Out Radiator and Closing Rear Access Door . . . . .	17
Reinstalling Covers . . . . .	17

## Appendix

Torque Specifications . . . . .	18
Inches Hardware and Lock Nuts . . . . .	18
Metric Hardware and Lock Nuts . . . . .	19

**LOFTNESS** ™

## Dealer/Owner Information

Some components of the Universal Hydraulic Oil Cooler Cab Mount Kit for the Kubota SVL97-3/SVL110-3 are shipped disassembled and need to be removed from their shipping positions, assembled, and secured in their operating position before being delivered to the owner.

To ensure safe and proper set-up of the oil cooler cab mount kit, it is mandatory that you thoroughly study this manual and follow its recommendations and information. Proper assembly is essential to prevent injury or damage and to maximize the life of the oil cooler.

For specific operating and maintenance instructions, specifications, and serviceable parts for the Loftness Universal Oil Cooler, refer to the Owner's Manual that is shipped with each cooler, or visit [www.loftness.com](http://www.loftness.com) for an electronic file of the manual.

Keep all factory-installed track loader parts that will be replaced by any new Loftness Oil Cooler Cab Kit parts. Those parts will need to be reinstalled should the Oil Cooler Cab Kit ever need to be removed from the track loader.

Continuous improvement and advancement of Loftness products may result in changes to this equipment that may not be reflected in this publication. Loftness reserves the right to make product improvements to the oil cooler cab mount kit at any time. Although great care has been taken to ensure the accuracy of this publication, Loftness does not assume any liability for errors or omissions.

## Dealer/Owner Responsibility

Assemble and set up the oil cooler cab mount kit in a safe manner and in accordance with all applicable local, state, and federal codes, regulations and/or laws, and in compliance with on-product labeling and these instructions.

Make sure that all personnel employed to set up and assemble the oil cooler cab mount kit:

- has read this manual and thoroughly understands safe and correct installation procedures.
- is familiar with the oil cooler and track loader.
- has a full understanding of the tools and/or equipment used to set up the oil cooler cab mount kit, such as hoists, power tools, etc.

Make sure the oil cooler cab mount kit is installed correctly before being placed into service.

Fulfill and assist the owner with all warranty obligations so as not to void the warranties. The warranty policy included in the Owner's Manual for the oil cooler outlines the warranty policy of Loftness.

# Safety Instructions

---

## Safety First

Accidents can be prevented by recognizing the causes or hazards before an accident occurs and doing something about them. Regardless of the care used in the design and construction of the oil cooler cab mount kit, there are some areas that cannot be safeguarded without interfering with accessibility and efficient operation.

	<b>Safety Alert Symbol</b> This message alert symbol identifies important safety messages on the product and in this manual. When you see this symbol, be alert to the possibility of personal injury and carefully read the message that follows.
---	---

In this manual and on decals used on the oil cooler the words **DANGER, WARNING, CAUTION, IMPORTANT,** and **NOTE** are used to indicate the following:

**DANGER:** This word warns of immediate hazards which, if not avoided, will result in severe personal injury or death. The color associated with Danger is RED.



**WARNING:** This word refers to a potentially hazardous situation which, if not avoided, could result in severe personal injury or death. The color associated with Warning is ORANGE.

**CAUTION:** This word refers to a potentially hazardous or unsafe situation that, if not avoided, may result in minor or moderate injury. It may also be used to alert against unsafe practices. The color associated with Caution is YELLOW.

**IMPORTANT:** Highlights information that must be heeded.

**NOTE:** A reminder of other related information that needs to be considered.

If Safety Decals on the oil cooler are ISO two panel pictorial, decals are defined as follows:

- The first panel indicates the nature of the hazard.
- The second panel indicates the appropriate avoidance of the hazard.
- Background color is YELLOW.
- Prohibition symbols such as   and  if used, are RED.

**Be certain all assemblers are aware of the dangers indicated by safety decals applied to the oil cooler, and be certain they follow all safety decal instructions. Contact Loftness for safety decal replacement.**

Loftness cannot anticipate every possible circumstance that may involve a potential hazard. The warnings in this manual are not all inclusive.

## Safety Rules

**These are general safety considerations. Additional precautions may be necessary to set up the oil cooler cab mount kit in a safe manner. Be certain you are operating your equipment and tools in accordance with all safety codes, OSHA rules and regulations, insurance requirements and local, state, and federal laws while setting up this Loftness unit.**

### Set-up Safety

- Disconnect battery connections before beginning the installation.
- Do not allow anyone to set up and/or assemble the oil cooler cab mount kit until he or she has read the set-up manual and is completely familiar with all safety precautions.
- Become familiar with the safety decals on the oil cooler.
- Do not allow inexperienced persons unfamiliar with the track loader, or the tools/equipment used to set up the oil cooler cab mount kit, to perform any set up procedures.
- Do not allow persons under the influence of alcohol, medications, or other drugs that can impair judgment or cause drowsiness to set up the oil cooler cab mount kit.
- Make sure the set-up area is clear of any distracting objects. Keep work areas clean and free of grease and oil to avoid slipping or falling.

## Safety Rules (Cont'd)

- Keep children, bystanders and other workers away from the unit while being set up.
- Wear safety glasses, ear protection, respirators, gloves, hard hats, safety shoes and other protective clothing when required.
- It is the dealer/owner's responsibility to be aware of work area hazards when assembling the oil cooler cab mount kit.
- Do not replace components or parts with other than factory-supplied parts. To do so may decrease the effectiveness of the oil cooler. If you notice any missing or damaged parts contact Loftness immediately.
- Never attempt to make any adjustments to the oil cooler cab mount kit if the engine is running or the key is in the "ON" position in the track loader. Before leaving the operator's position, disengage power to the track loader and remove ignition key.

## Hoist (Lifting) Safety

During maneuvering and set-up, it is recommended that a power hoist, or lift, be used to lift the cooler cab mount kit assembly into the operating position.

- Make sure the lifting device (hoist or heavy equipment) is capable of lifting the specified parts and/or assemblies.
- All personnel must be properly trained and experienced lift operators.

## Hydraulic Safety



**WARNING:** *Contact with high pressure fluids may cause fluid penetration and burn hazards. Fluid that is under pressure can penetrate body tissue. Fluid penetration can cause serious injury and possible death. If fluid is injected into the skin, seek medical attention immediately!*

- Always wear safety goggles or glasses when working on hydraulic system to avoid eye injury.
- The hydraulic system is under high pressure. Make sure all lines and fittings are tight and in good condition. These fluids escaping under high pressure can have sufficient force to penetrate skin and cause serious injury.
- Never check for leaks by using any part of your body to feel for escaping fluid.
- To prevent serious personal injury from escaping high pressure fluid, never attempt to inspect, service or disassemble any part of the hydraulic system until all pressure has been relieved from the system.

## California Proposition 65 Warning



**WARNING:** *This product can expose you to Mineral Oil, which is known to the State of California to cause cancer. For more information, go to [www.p65warnings.ca.gov](http://www.p65warnings.ca.gov).*

# Options

## Universal Oil Cooler Kit (Kubota SVL97-3/SVL110-3) Options

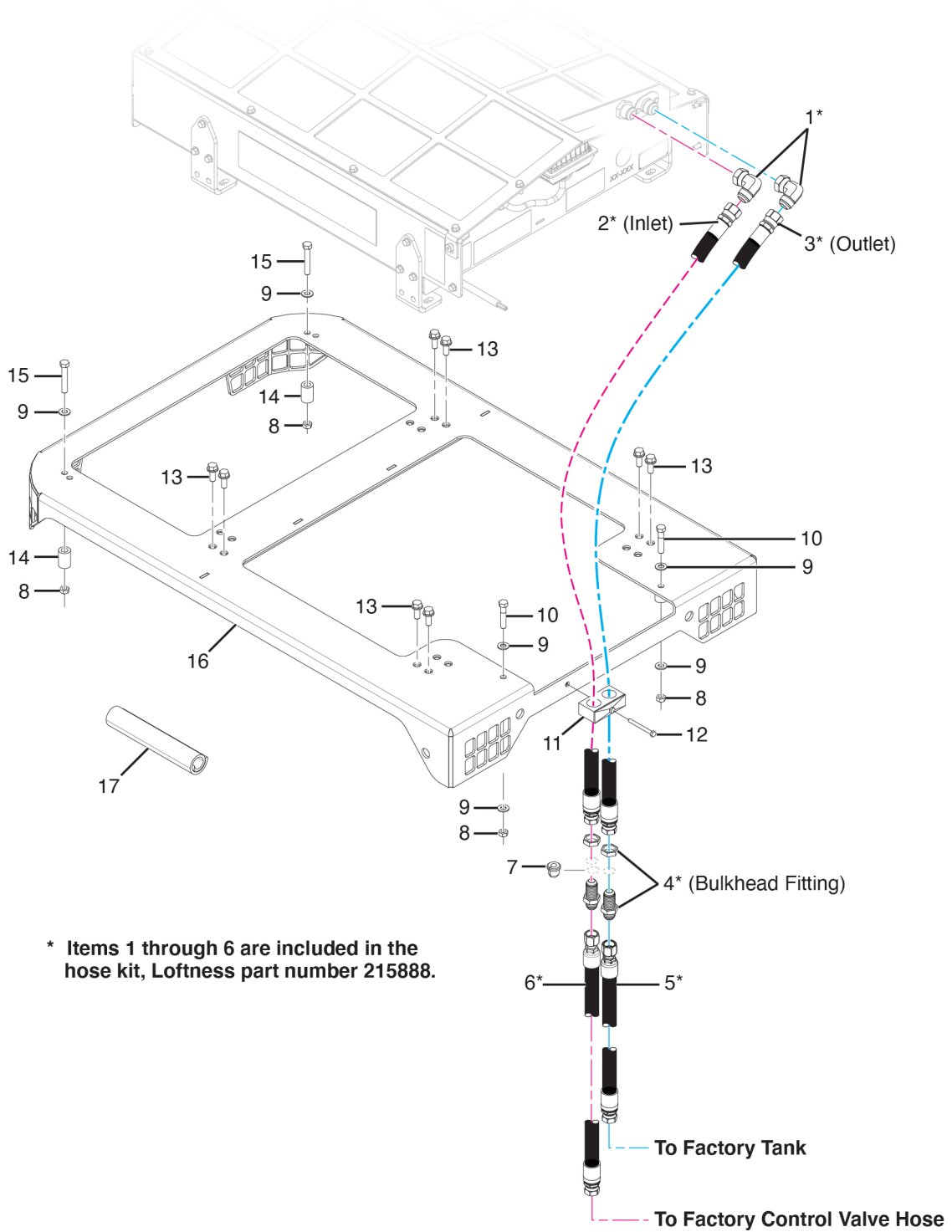

---

**Universal Oil Cooler Kit (Kubota SVL97-3/SVL110-3) Options**

#	QTY.	PART #	DESCRIPTION
1*	2	N19270	ELBOW, 90 DEG - 16MJC - 16FJC
2*	1	215889	HOSE, 1 X 52 -12FJIC -16FJIC
3*	1	215891	HOSE, 1 X 53.5 -12FJIC -16FJIC
4*	2	N28816	ADAPTER, BULKHEAD -12MJIC
5*	1	215893	HOSE, 3/4 X 62.5 -12FBSPP -12FJIC
6*	1	215895	HOSE, 3/4 X 80 -12MBSPP -12FJIC
7	1	215898	GROMMET, RUBBER MODIFIED
8	4	4054	NUT, LOCK 1/2" TOP
9	6	4068	WASHER, 1/2" SAE FLAT
10	2	4218	BOLT, 1/2" X 2-1/2" GRADE 5
11	1	N29662	CLAMP, 1" HYD HOSE DOUBLE
12	1	4004	BOLT, 5/16" X 3" GRADE 5
13	8	N18360	BOLT, 1/2-13 X 1-1/4 SER FLG
14	2	212428	SPACER, .625ID X 1.125OD LG
15	2	4496	BOLT, 1/2IN X 2-3/4IN GR 5
16	1	212430	WLDMT, KUBOTA SVL75-3 CAB MNT
17	1	215887	INSTRUCTIONS, KUBOTA COOLER MNT

\* Items 1 through 6 are included in the hose kit, Loftness part number 215888.

# Installation Instructions

## Set-up

Park the track loader on a firm, flat and level surface.

Lower the lift arms to the ground and stop the engine.

	<b>WARNING:</b> <i>Crushing hazard. Death or serious injury can result from falling lift arm and/or attachment.</i>
---	---

Shut down and lock out power to the track loader.

	<b>WARNING:</b> <i>Failure to shut down and lock out power could result in serious injury, or death.</i>
---	--

**NOTE:** *Some procedures during the installation may be easier with the assistance of another person.*

## Mounting the Oil Cooler to the Cooler Mounting Frame

**NOTE:** *The cab on the track loader must be in the operation position during this procedure. If the cab is tilted back into the maintenance position, lower back down.*

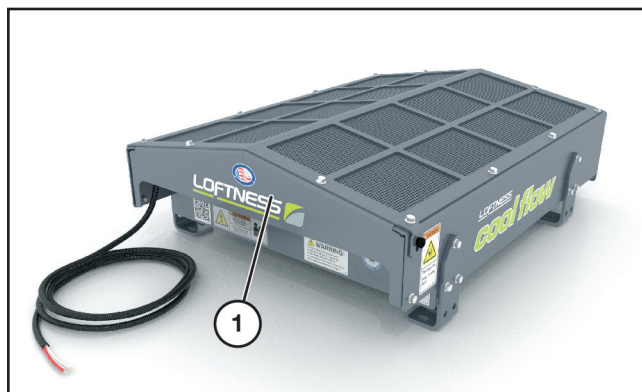

While the oil cooler is still on the ground, remove the back cover (1). This allows for easier access to the hydraulic fittings when connecting the hydraulic hoses.



Using a hoist, lift the oil cooler and place on top of the cooler mounting frame. Align the slotted holes in the mounting brackets to the holes in the mounting frame.

Secure using 1/2"-13 x 1-1/4" bolts (1) supplied with the kit. Two bolts at each bracket (8 total).

## Mounting the Cooler Kit to the Cab

### Temporarily Removing the Front Lights

**NOTE:** *The front lights will need to be temporarily removed to access two holes used to secure the cooler kit. They will be reinstalled when the mounting is complete so keep in mind the order and orientation when removing.*

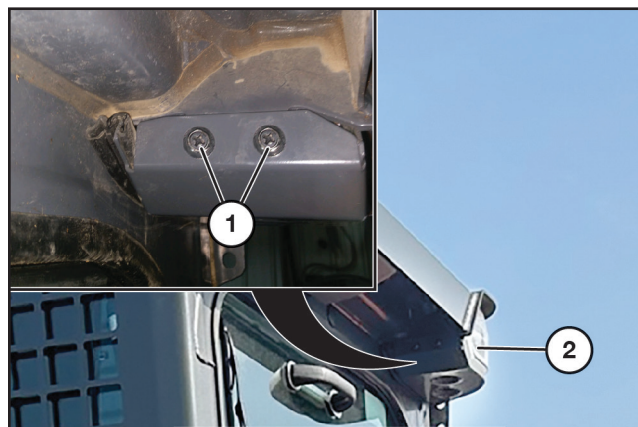

Remove the two inner bolts (1) securing the front left side headlight (2).

# Installation Instructions

## Mounting the Cooler Kit to the Cab (Cont'd)

### Temporarily Removing the Front Lights (Cont'd)

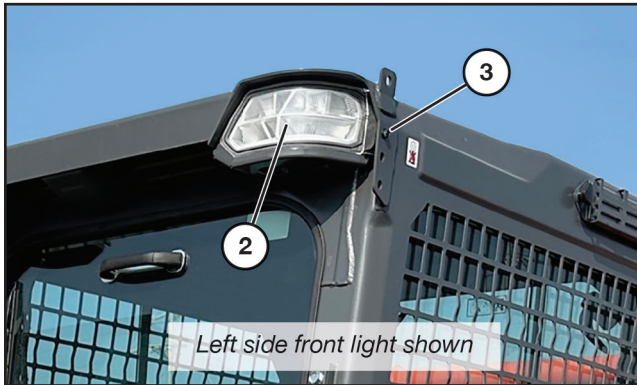

While supporting the light (2), remove the outer bolt (3).

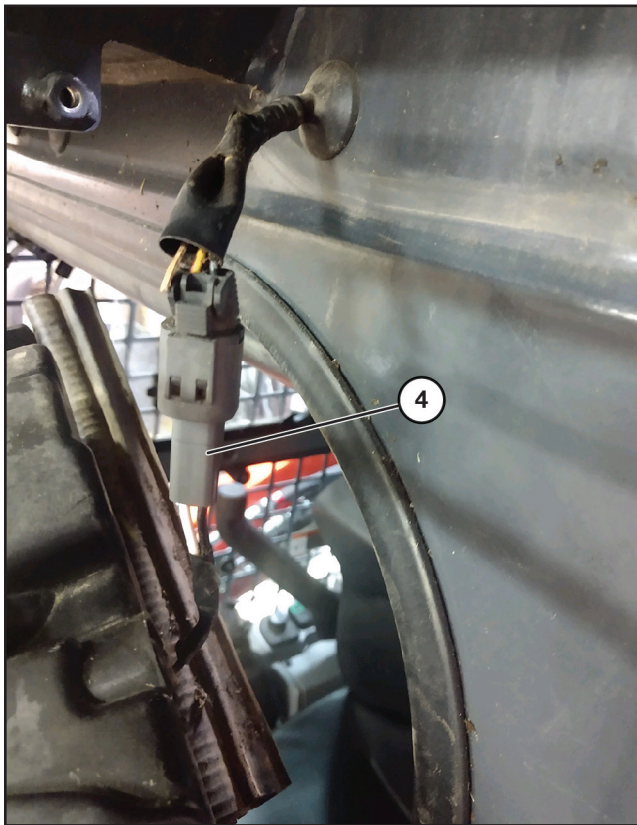

Disconnect the headlight wiring harness (4) and carefully remove the light. Set aside.

Repeat the procedure on the front right side headlight.

## Mounting



**WARNING:** The cooler mounting frame and oil cooler are heavy. Use a power hoist to lift and place the assembly into position. Failure to do so could result in serious injury, or death.

Ensure the antenna on the rear of the cab is folded down.



Lift the cooler kit and place into position on top of the track loader cab.

Align the holes in the cooler mounting frame with the holes on the cab.

**NOTE:** Before installing the mounting hardware, refer to the exploded view on page 4 for reference.

*(Procedure continued on following page.)*

# Installation Instructions

## Mounting the Cooler Kit to the Cab (Cont'd)

### Mounting (Cont'd)

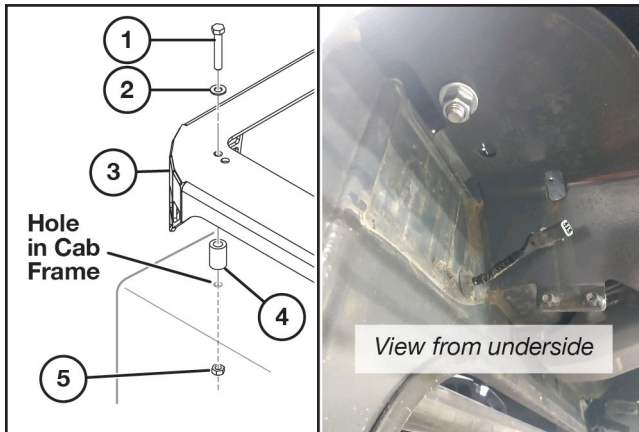

When the front holes are aligned, insert a bolt (1) - part no. 4496 with washer (2) - part no. 4068 from the top side of the cooler mount (3), and install a spacer (4) - part number 212428 on the underside of the cooler mount.

From the underside of the cab frame, install a nut (5) - part no. 4054 onto the bolt. Hand tighten the hardware.

Repeat the procedure on the opposite side of the cooler mounting frame.

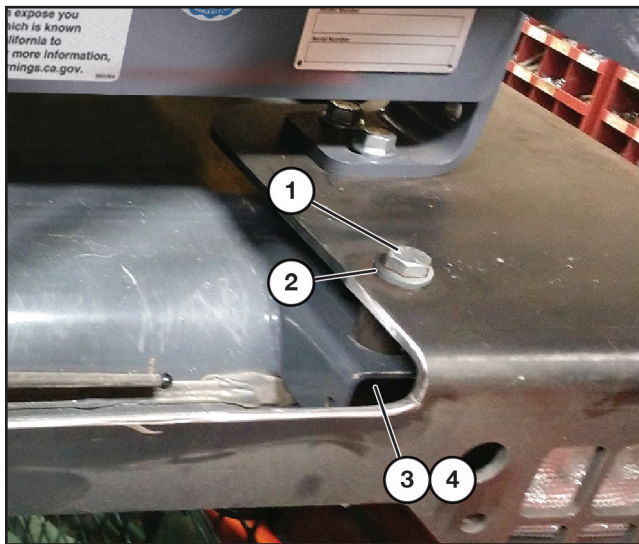

When the holes adjacent to the rear cab lights are aligned, insert a bolt (1) - part no. 4218 with washer (2) - part no. 4068 from the top side of the cooler mounting frame as shown above.

From the underside of the bracket on the cab, install a washer (3) - part no. 4068 and nut (4) - part no. 4054 onto the bolt. Hand tighten the hardware.

Repeat the procedure on the opposite side of the cooler mounting frame.

**IMPORTANT:** Before tightening the hardware, push the cooler mounting frame towards rear of cab.

Tighten the mounting hardware at all four locations.

## Reinstalling the Front Lights

Return the front lights back into position. Connect the wiring harnesses and reinstall all hardware.

## Installing Hydraulic Hoses and Electrical Wiring Harness

### Removing Access Panel

Start the loader and raise the lift arms.

Shut down and lock out power to the track loader.

Install the lift arm stop onto the lift cylinder. For detailed instructions, refer to the Kubota SVL97-3/SVL110-3 Owner/Operator's Manual.

 **WARNING:** Crushing hazard. Failure to shut down, lock out the power, and install the lift arm stop may result in serious injury or death.



Remove the screened access panel (1) on the rear left side of the loader and set aside.

# Installation Instructions

## Drilling Routing Holes

Three holes will need to be drilled into the loader frame - two for bulkhead fittings used with the oil cooler hydraulic system, and one for the wiring harness.

**IMPORTANT:** A Kubota loader wiring harness runs directly beneath the drilling area. Carefully move the harness out of the way before drilling.

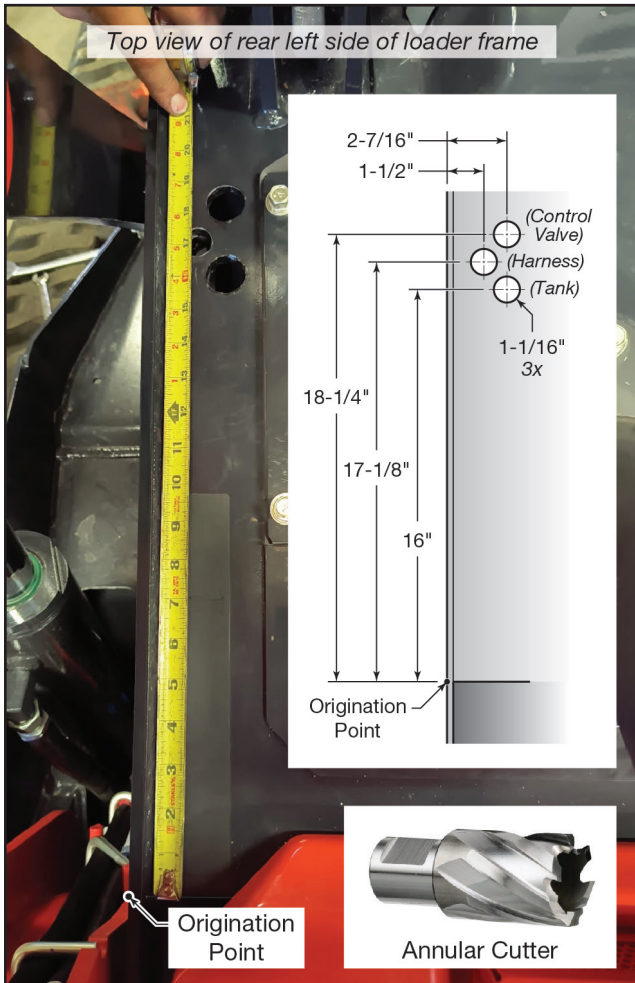

Use a tape measure to lay out the hole locations. Refer to the image above for exact dimensions.

**IMPORTANT:** Make sure all dimensions originate from the point shown in the drawing above.

Place a mat inside the engine bay beneath the hole locations to catch the metal filings. Do not let any filings enter the engine bay.

Using a 1-1/16" annular cutter, drill the three holes in the locations show above.

## Draining Hydraulic Oil

Some hydraulic hoses and other hydraulic components will be disconnected during the installation procedure. The loader cab will need to be tilted into the maintenance position and the hydraulic oil in the loader will need to be drained to avoid excessive leaks and spills.

**IMPORTANT:** The following procedure provides basic instructions for draining hydraulic oil. For detailed instructions on tilting the cab and draining the system, refer to the Kubota SVL97-3/SVL110-3 Owner/Operator's Manual.

**NOTE:** The Kubota SVL97-3/SVL110-3 contains approximately 10 gallons (30.28 liters) of hydraulic oil in tank.

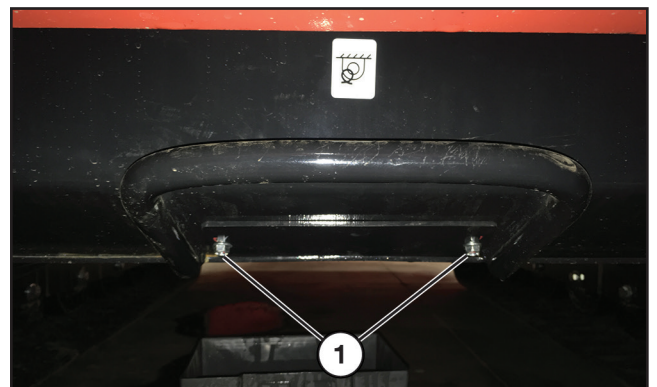

Remove the two bolts (1) securing the cover to the bottom of the track loader and lower the cover.

Provide a container or other collection device for the hydraulic oil to drain into.



Remove the drain plug (1) and drain the hydraulic oil.

Reinstall the plug after all of the hydraulic oil has drained.

# Installation Instructions

## Disconnecting Kubota Loader Hoses

Some hoses will need to be temporarily disconnected to access the hoses and fittings required for the oil cooler kit installation.

**IMPORTANT:** Label the hoses referenced in the following steps and take photos before disconnecting. This will help ensure all hoses are reconnected correctly later in the installation.

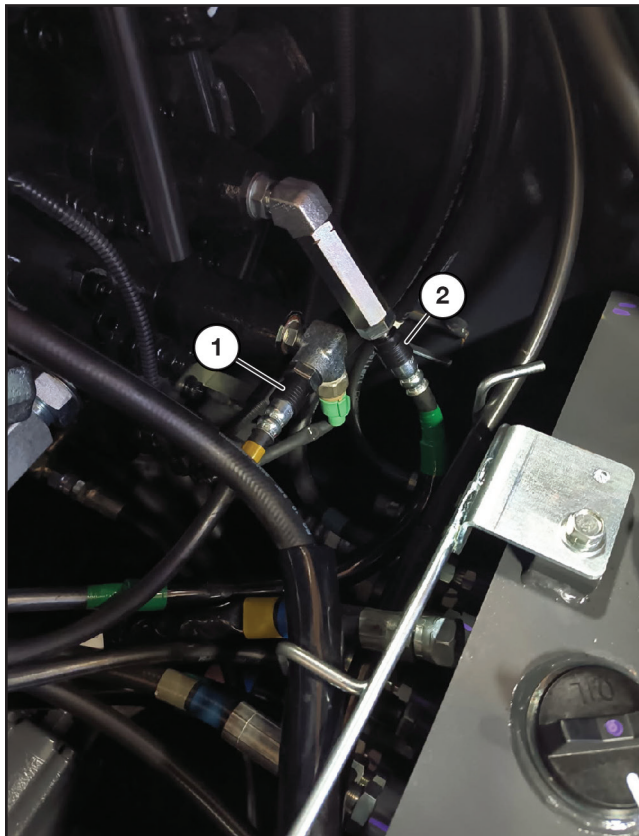

Disconnect the two quick-connect hoses at the locations shown above. They are factory labeled with colored tape: Yellow (1); Green (2).

Position the hoses out of the way with the ends facing upward to minimize fluid leakage. Cover the hose ends to prevent contamination of the hydraulic system.

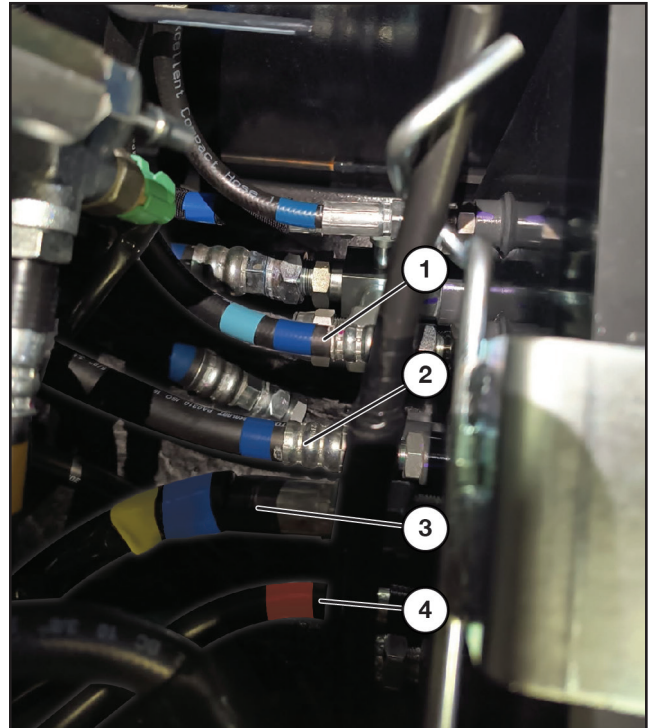

Disconnect the four hoses at the locations shown above. They are factory labeled with colored tape: Blue and Light Blue (1); Blue (2); Blue and Yellow (3); Red (4).

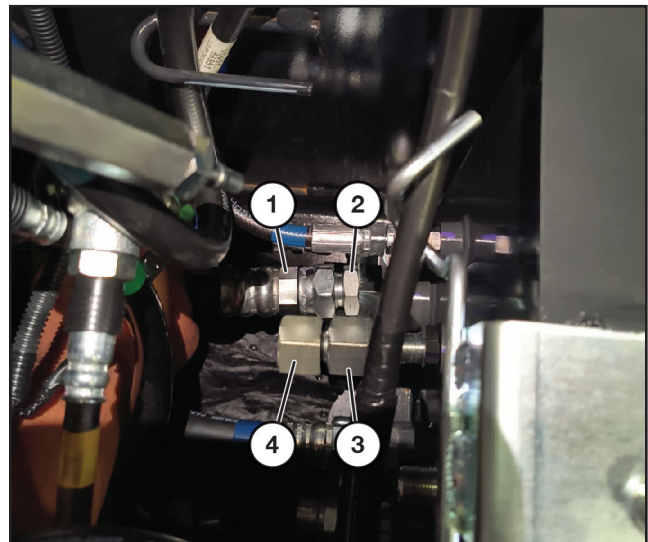

Disconnect and plug the control valve hose (1 - labeled with Blue tape) with a -12MBSPP plug (2).

Cap the tank fitting (3) with a -12FBSPP cap (4).

**NOTE:** Plug and cap are dealer-supplied.

# Installation Instructions

## Connecting and Routing Oil Cooler Kit Hoses

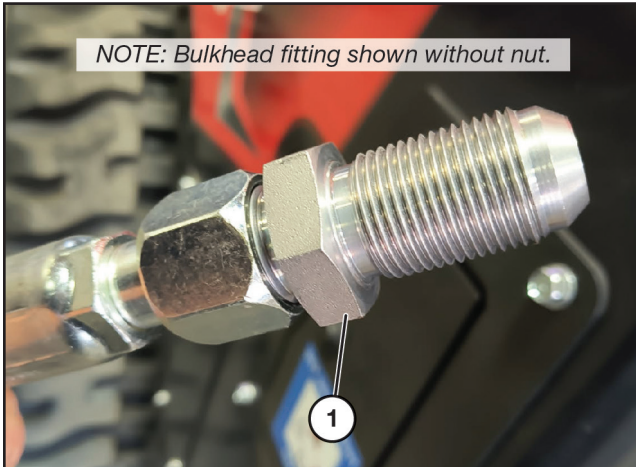

Install a bulkhead fitting (1) - part no. N28816 onto the JIC ends of the two hydraulic hoses included in the cooler kit - part nos. 215895 (control valve) and 215893 (tank). The long end of the bulkhead fittings will extend upward through the holes drilled into the loader frame earlier.



Route both hoses, one at a time, down into the engine bay as shown. Use the opening from the screened access panel that was removed earlier to assist with routing.

## Hose Connection - Control Valve/Oil Cooler Inlet (215895)

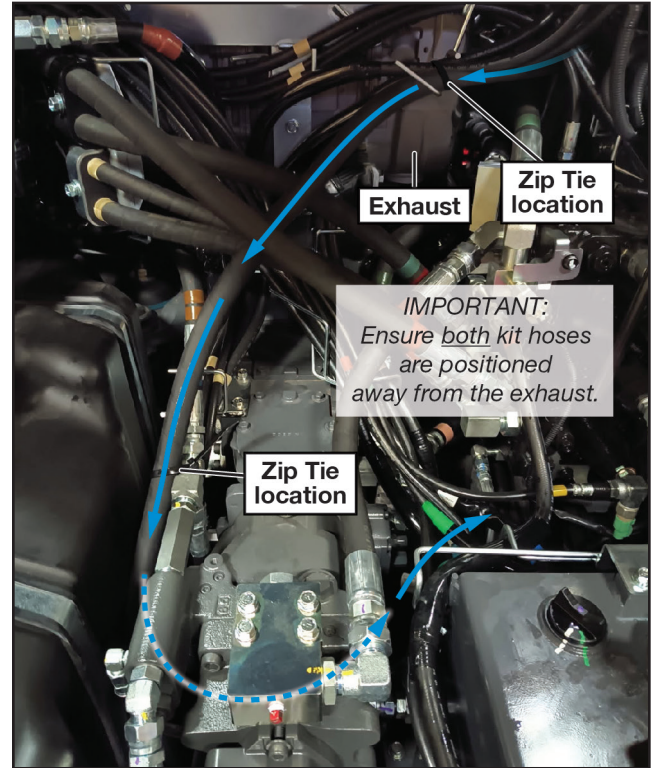

Route the control valve hose (215895) from the engine bay access opening, guiding it down and around beneath the hydro (HST). Use the arrows in the image above to identify the hose's installation direction and routing path.

**IMPORTANT:** Ensure both kit hoses are positioned away from the exhaust to prevent heat damage. Secure with zip ties when both hose connections are complete.

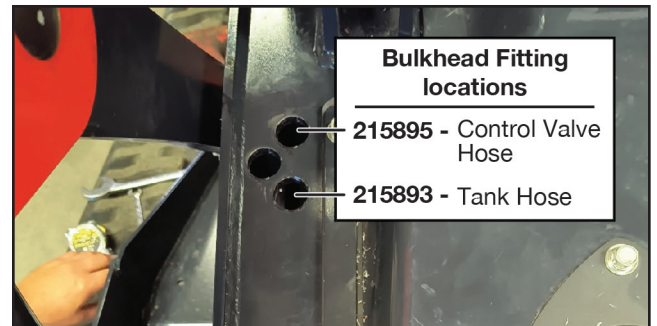

Install the bulkhead fitting with control valve hose (215895) into the front hole (closest to the cab) and secure with the nut.

*(Procedure continued on following page.)*

# Installation Instructions

## Connecting and Routing Oil Cooler Kit Hoses (Cont'd)

### Hose Connection - Control Valve/Oil Cooler Inlet (215895) (Cont'd)

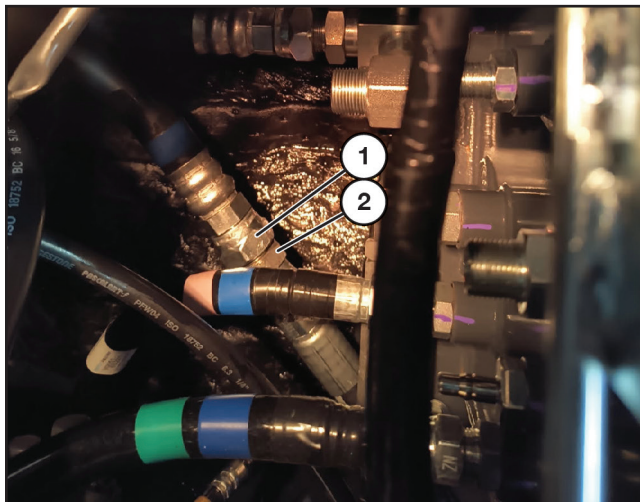

Remove the -12MBSPP plug (which was installed earlier) from the Kubota factory hose (1), then connect that hose to the end of the kit hose (2) - (215895).

After the connections are made, secure the hose with zip ties. Refer to the image on the previous page for the recommended location.

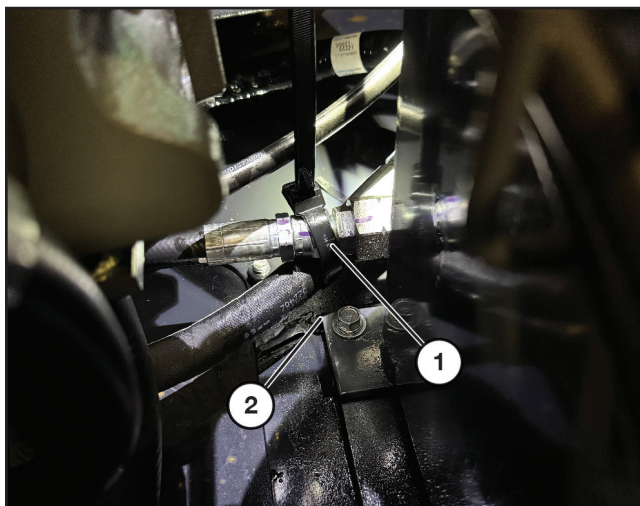

Secure kit hose 215895 using a zip tie (1) at the location shown above to prevent contact with the corner (2) of the plate supporting the hydraulic tank.

### Hose Connection - Hydraulic Tank/Oil Cooler Outlet (215893)

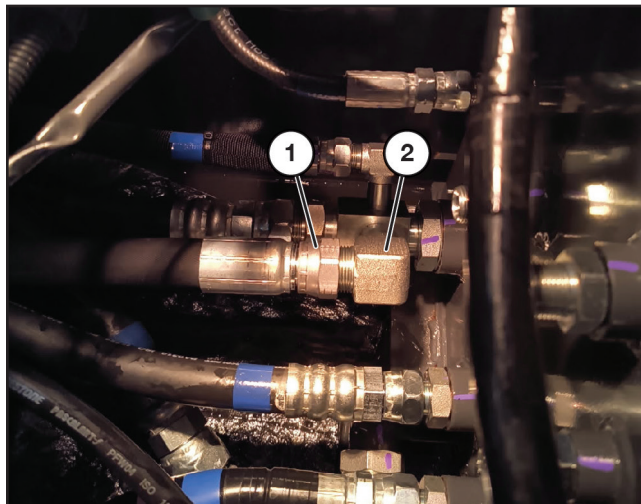

Route the tank hose (1) - (215893) from the engine bay access opening, behind the control valve, and down to the hydraulic tank.

Remove the -12 FBSPP cap, then connect the hose to the elbow fitting (2).

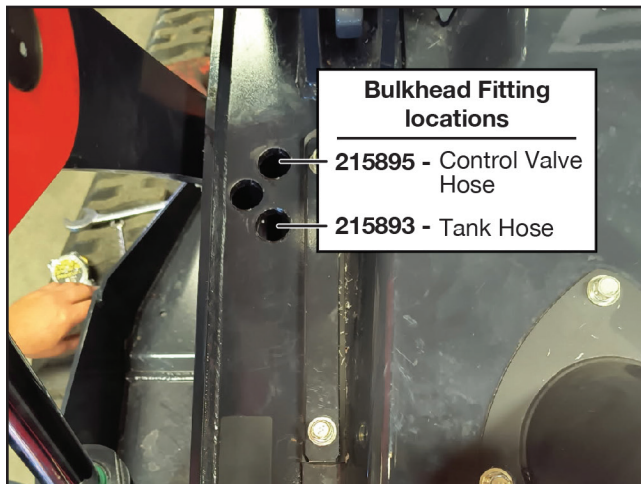

Install the bulkhead fitting with tank hose (215893) into the rear hole (furthest from the cab) and secure with the nut.

## Reconnecting Loader Hoses

Reconnect the Kubota loader hoses that were disconnected at the beginning of the installation. Refer to the photos, labels, and documentation recorded to ensure proper reconnection.

# Installation Instructions

## Refilling Hydraulic Tank

Once all kit hoses have been installed and tightened, and all Kubota loader hoses have been properly reconnected, hydraulic oil will need to be added back into the hydraulic system.

Refer to the Kubota SVL97-3/SVL110-3 Owner/Operator's Manual for adding hydraulic oil, keeping in mind that the oil cooler cab mount kit is shipped without hydraulic oil. This addition to the hydraulic system will need to be taken into consideration when filling.

## Oil Cooler Hydraulic Connections

Return the loader cab to the operating position. Refer to the Kubota SVL97-3/SVL110-3 Owner/Operator's Manual for proper lowering instructions.

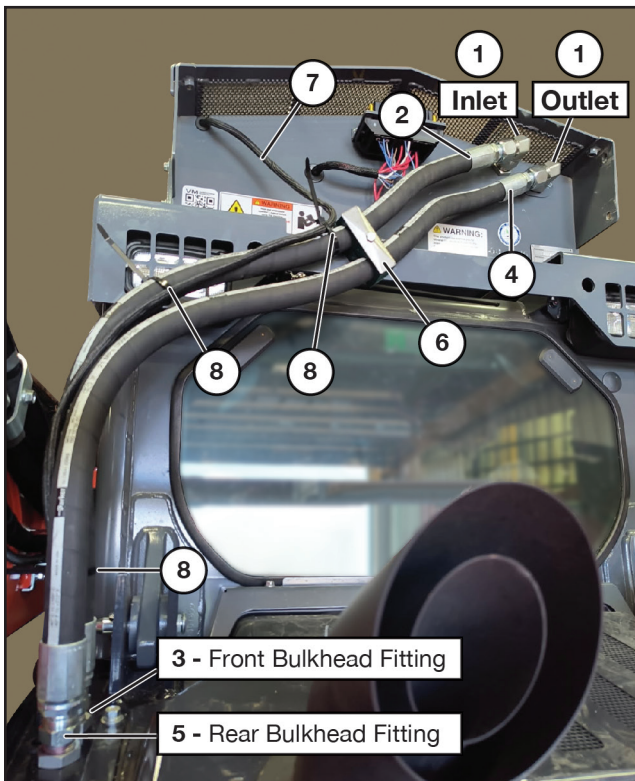

Connect the two elbow fittings (1) - part no. N19270 to the oil cooler INLET and OUTLET ports and position at the angle shown above. Tighten.

Connect one end of the INLET hose (2) - part no. 215889 supplied with the kit to the INLET fitting on the oil cooler.

Connect the opposite end of the INLET hose to the front bulkhead fitting (3) - (closest to the loader cab).

Connect one end of the OUTLET hose (4) - part no. 215891 supplied with the kit to the OUTLET fitting on the oil cooler.

Connect the opposite end of the OUTLET hose to the rear bulkhead fitting (5).

Install the hose clamp (6) - part no. N29662 and position hoses as shown.

**NOTE:** *Keep hoses to the left-rear corner of the cab. Avoid any potential pinch points or sharp turns that could cut or wear on the hoses or wiring harness.*

Ensure all fittings, hose connections, and hose clamp are tightened.

## Routing the Cooler Wiring Harness

Route the wiring harness (7 - see image on left) from the oil cooler through the hole drilled earlier adjacent to the bulkhead fittings and into the engine bay. Secure the harness to the inlet hose using zip ties at the locations (8 - see image on left) shown.

**NOTE:** *When complete, refer to the exploded drawing on page 4 to verify hose routing and connections.*

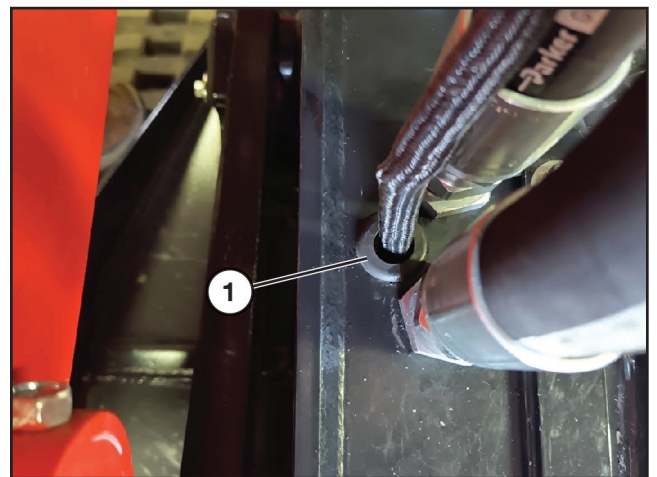

Install the grommet (1) - part no. 215898 around the wire harness and insert it into the hole drilled earlier adjacent to the bulkhead fittings.

*(Procedure continued on following page.)*

# Installation Instructions

## Routing the Cooler Wiring Harness (Cont'd)

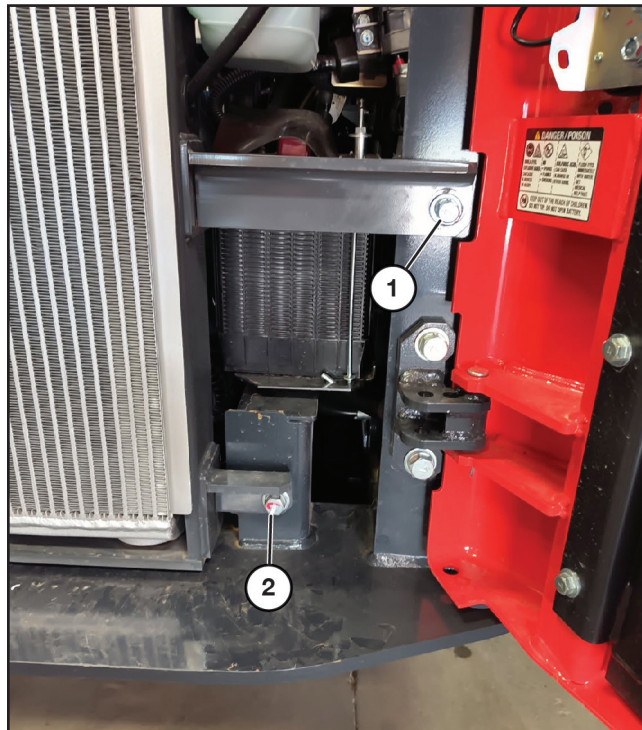

Open the rear access door on the loader. Refer to the Kubota SVL97-3/SVL110-3 Owner/Operator's Manual for instructions.

Remove the two bolts and washers (1 and 2) securing the swing-out radiator to the loader frame.

Swing the radiator out to access the engine bay.

**NOTE:** To allow the swing-out radiator to open more easily, you may need to remove the radiator hose from the retaining brackets located in the engine bay, above the radiator. Refer to the Kubota SVL97-3/SVL110-3 Owner/Operator's Manual if needed.

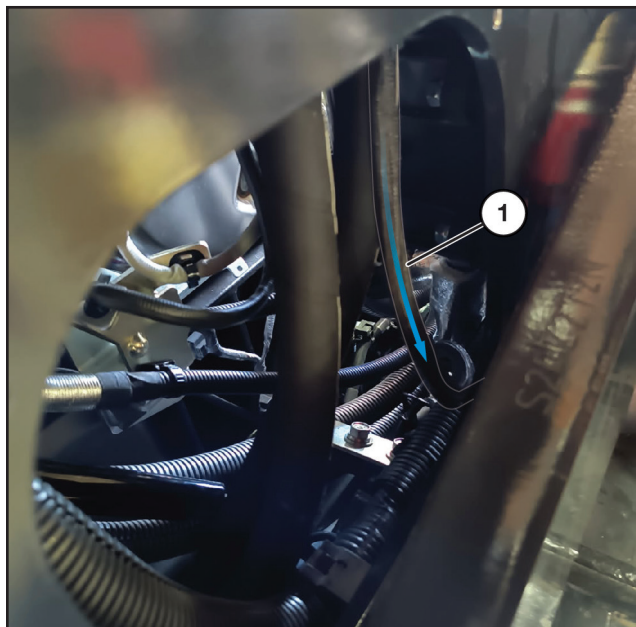

Route the harness along the left rear side of the engine bay, then down to the bottom of the engine bay

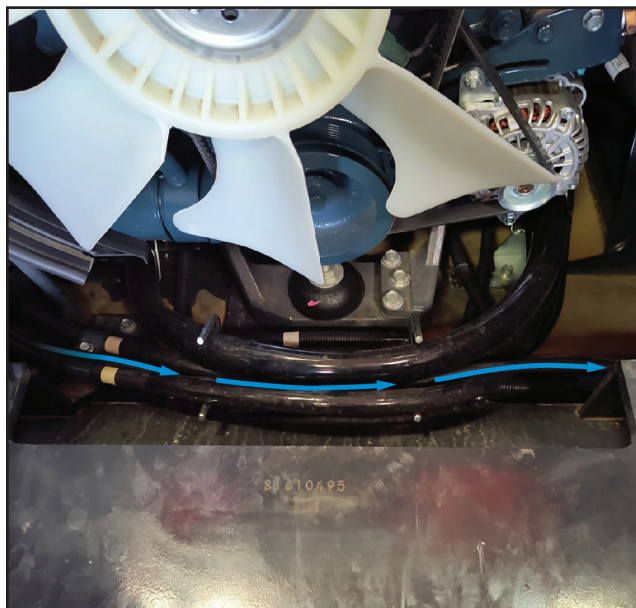

Continue routing the harness along the back of the engine bay toward the battery.

Use the arrows in the images above to identify the harness' direction and routing path.

**NOTE:** Temporarily close the swing-out radiator to check for clearance. Use zip ties to keep the harness in place.

# Installation Instructions

## Loftness Cooler Position Schematic (Wire Harness N68127)

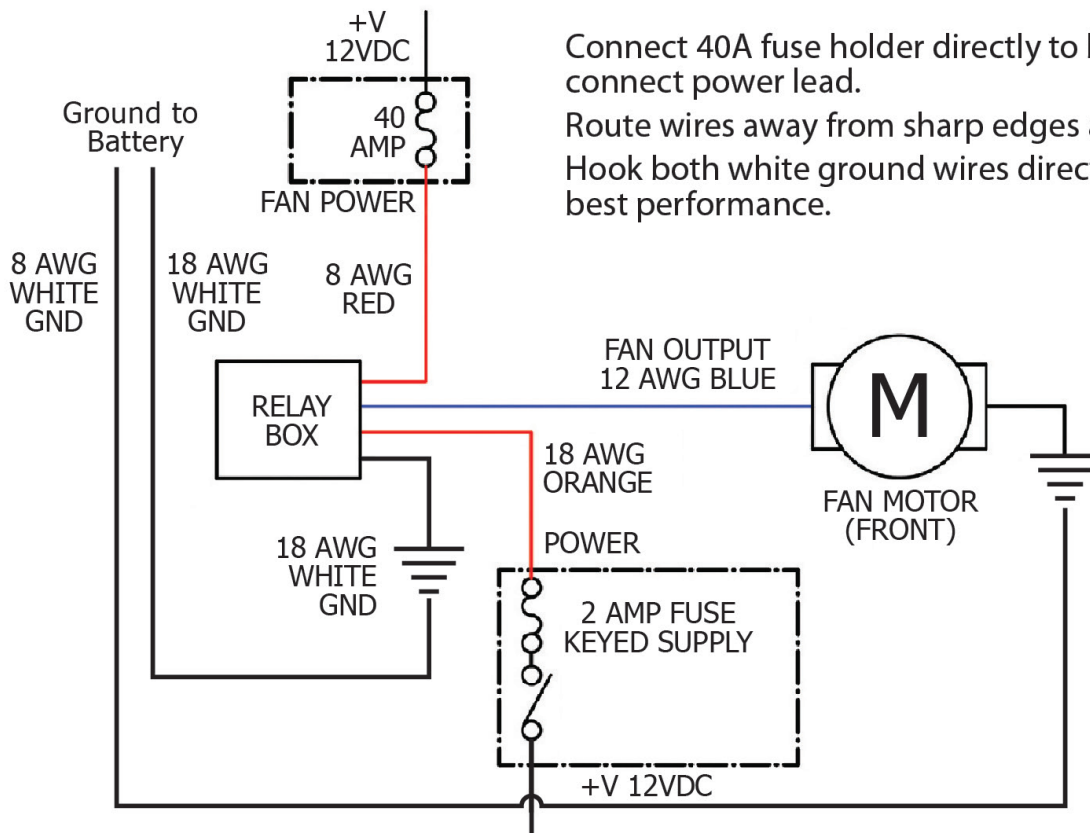

Connect 40A fuse holder directly to battery, then connect power lead.  
Route wires away from sharp edges and heat sources.  
Hook both white ground wires directly to battery for best performance.

# Installation Instructions

## Electrical Connections

### Battery

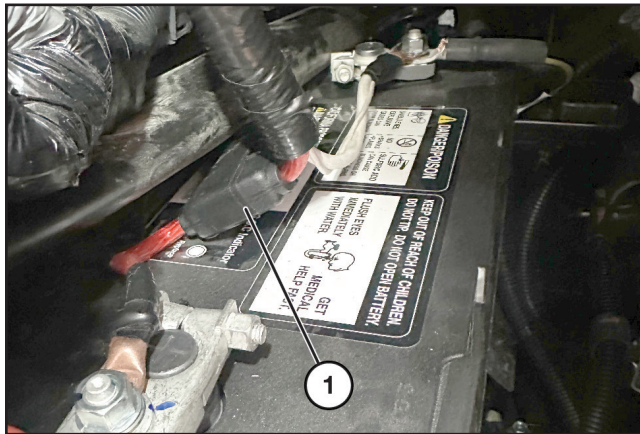

Connect the fuse holder (1) (supplied with the oil cooler) to the red (8 AGW) wire from the cooler harness, and to the battery positive.

Connect both white wires (8 AGW and 18 AGW) from the cooler harness to battery ground.

Ensure the track loader's battery connections are reconnected properly.

### Keyed Power Source

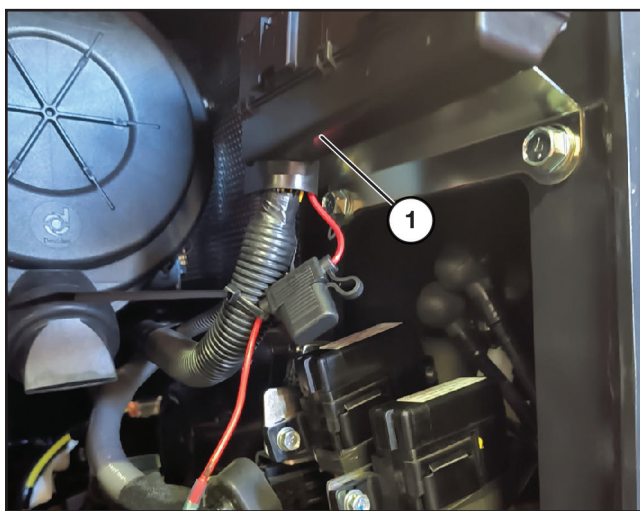

Connect the orange wire (18 AGW) from the cooler harness to the keyed power location on the track loader.

**NOTE:** Refer to the Kubota SVL97-3/SVL110-3 Owner/Operator's Manual or your dealer for a keyed power location.

## Check and Verify Fan Operation

### To Check Fan with Key On

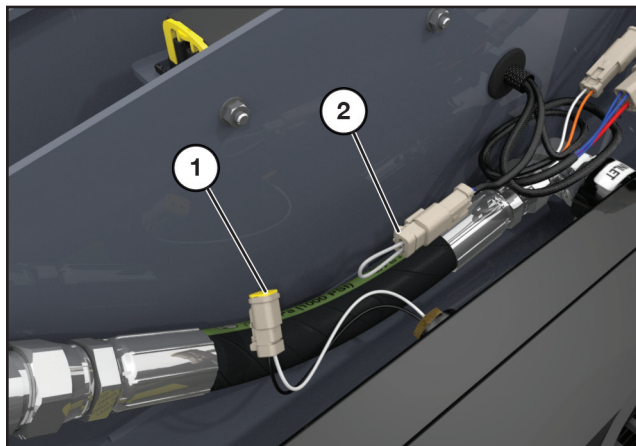

Remove the temperature sensor plug (1) on the main harness.

Use a jumper wire or Deutsch plug jumper (2) (dealer-made) to activate the fans. The front fan (Fan #1) will turn on immediately. The rear fan (Fan #2) will activate after approximately 25–30 seconds.

Preset 120° F temperature setting is non-adjustable.

When test is complete, remove the jumper wire and reconnect the temperature sensor plug to the main harness.

## Securing Hoses and Wiring Harness

Make sure the oil cooler hydraulic hoses and wiring harness are secure throughout. Use zip ties to secure where needed.

Avoid any potential pinch points or sharp turns that could cut or wear on the hoses or wires.

# Installation Instructions

## Testing the Oil Cooler Cab Kit

Ensure the oil cooler cab kit is completely and correctly installed. Ensure all hydraulic and wiring connections are tightened and secure.

Once the hydraulic oil level is fulfilled, start the track loader

Run for about 30 seconds, then shut down.

Recheck the hydraulic oil level. Add oil as needed. Refer to the Kubota SVL97-3/SVL110-3 Owner/Operator's Manual for adding hydraulic oil.

## Checking for Leaks

With the track loader turned off, inspect all hydraulic hose and fitting connections.



**WARNING:** Contact with high pressure fluids may cause fluid penetration and burn hazards. Fluid that is under pressure can penetrate body tissue. Fluid penetration can cause serious injury and possible death. If fluid is injected into the skin, seek medical attention immediately! Refer to "Hydraulic Safety" on page 3 for hydraulic safety warnings.

## Securing Swing-Out Radiator and Closing Rear Access Door

Return the swing-out radiator back into the operating position and secure with the two bolts with washers that were removed earlier.

**NOTE:** If the radiator hose was moved from the retaining brackets, ensure that it is secured back into position.

Shut and secure the loader's rear access door.

Refer to the Kubota SVL97-3/SVL110-3 Owner/Operator's Manual for any of these instructions as needed.

## Reinstalling Covers

Ensure the lift arms are raised, the engine is shut down, and power to the track loader is locked out.



**WARNING:** Failure to shut down and lock out power could result in serious injury, or death.

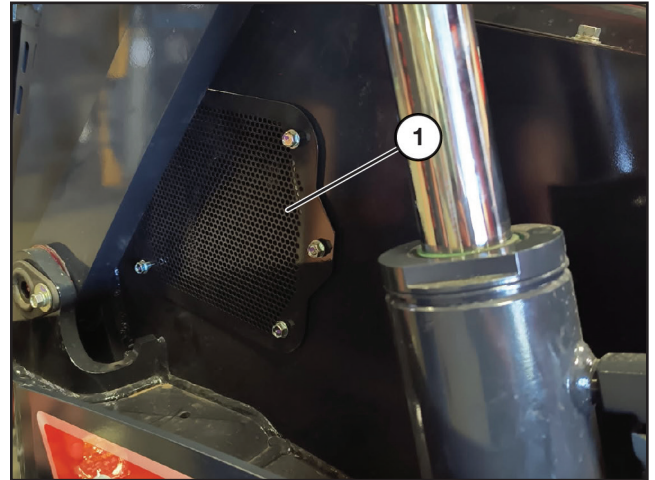

Reinstall the screened access panel (1).

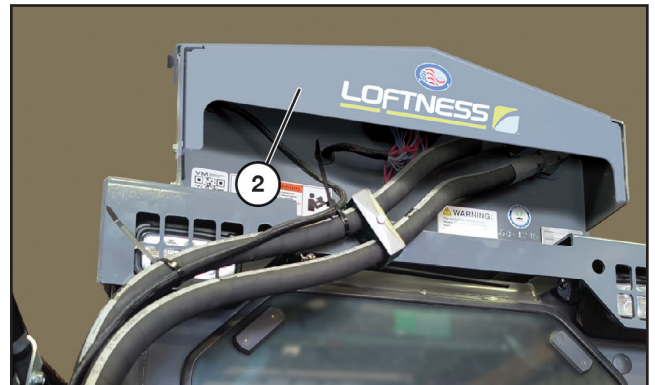

Place the rear cover (2) back onto the Loftness oil cooler. Reinstall all hardware and tighten.

Remove the lift arm stop from the lift cylinder and return it to its storage location. Refer to the Kubota SVL97-3/SVL110-3 Owner/Operator's Manual for instructions.

Start the loader and lower the lift arms.

Turn off the loader.

The installation is now complete.

# Appendix

## Torque Specifications

### Inches Hardware and Lock Nuts

#### TORQUE CHARTS Minimum Hardware Tightening Torques

Normal Assembly Applications  
(Standard Hardware and Lock Nuts)

SAE Gr. 2 Nominal Size	SAE Grade 5		SAE Grade 8		LOCK NUTS			
	Unplated or Plated Silver	Plated W / ZnCr Gold	Unplated or Plated Silver	Plated W / ZnCr Gold	Unplated or Plated Silver	Plated W / ZnCr Gold	Grade W / Gr. 5 Bolt	Grade W / Gr. 8 Bolt
1/4	55 in.-lb. (6.2 N•m)	72 in.-lb. (8.1 N•m)	86 in.-lb. (9.7 N•m)	112 in.-lb. (12.6 N•m)	121 in.-lb. (13.6 N•m)	157 in.-lb. (17.7 N•m)	61 in.-lb. (6.9 N•m)	86 in.-lb. (9.8 N•m)
5/16	115 in.-lb. (13 N•m)	149 in.-lb. (17 N•m)	178 in.-lb. (20 N•m)	229 in.-lb. (26 N•m)	250 in.-lb. (28 N•m)	324 in.-lb. (37 N•m)	125 in.-lb. (14 N•m)	176 in.-lb. (20 N•m)
3/8	17 ft.-lb. (23 N•m)	22 ft.-lb. (30 N•m)	26 ft.-lb. (35 N•m)	34 ft.-lb. (46 N•m)	37 ft.-lb. (50 N•m)	48 ft.-lb. (65 N•m)	19 ft.-lb. (26 N•m)	26 ft.-lb. (35 N•m)
7/16	27 ft.-lb. (37 N•m)	35 ft.-lb. (47 N•m)	42 ft.-lb. (57 N•m)	54 ft.-lb. (73 N•m)	59 ft.-lb. (80 N•m)	77 ft.-lb. (104 N•m)	30 ft.-lb. (41 N•m)	42 ft.-lb. (57 N•m)
1/2	42 ft.-lb. (57 N•m)	54 ft.-lb. (73 N•m)	64 ft.-lb. (87 N•m)	83 ft.-lb. (113 N•m)	91 ft.-lb. (123 N•m)	117 ft.-lb. (159 N•m)	45 ft.-lb. (61 N•m)	64 ft.-lb. (88 N•m)
9/16	60 ft.-lb. (81 N•m)	77 ft.-lb. (104 N•m)	92 ft.-lb. (125 N•m)	120 ft.-lb. (163 N•m)	130 ft.-lb. (176 N•m)	169 ft.-lb. (229 N•m)	65 ft.-lb. (88 N•m)	92 ft.-lb. (125 N•m)
5/8	83 ft.-lb. (112 N•m)	107 ft.-lb. (145 N•m)	128 ft.-lb. (174 N•m)	165 ft.-lb. (224 N•m)	180 ft.-lb. (244 N•m)	233 ft.-lb. (316 N•m)	90 ft.-lb. (122 N•m)	127 ft.-lb. (172 N•m)
3/4	146 ft.-lb. (198 N•m)	189 ft.-lb. (256 N•m)	226 ft.-lb. (306 N•m)	293 ft.-lb. (397 N•m)	319 ft.-lb. (432 N•m)	413 ft.-lb. (560 N•m)	160 ft.-lb. (217 N•m)	226 ft.-lb. (306 N•m)
7/8	142 ft.-lb. (193 N•m)	183 ft.-lb. (248 N•m)	365 ft.-lb. (495 N•m)	473 ft.-lb. (641 N•m)	515 ft.-lb. (698 N•m)	667 ft.-lb. (904 N•m)	258 ft.-lb. (350 N•m)	364 ft.-lb. (494 N•m)
1	213 ft.-lb. (289 N•m)	275 ft.-lb. (373 N•m)	547 ft.-lb. (742 N•m)	708 ft.-lb. (960 N•m)	773 ft.-lb. (1048 N•m)	1000 ft.-lb. (1356 N•m)	386 ft.-lb. (523 N•m)	545 ft.-lb. (739 N•m)

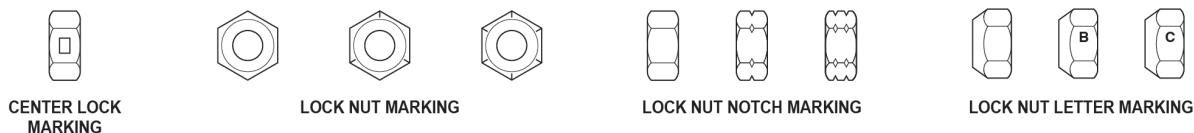
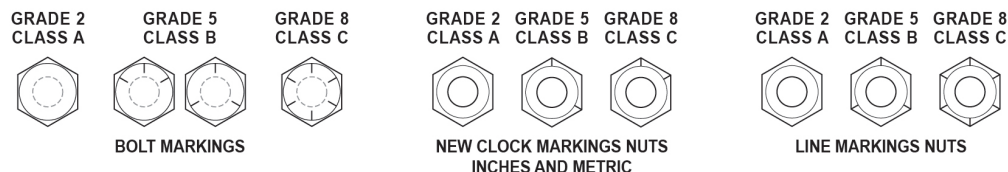

## Torque Specifications (Cont'd)

### Metric Hardware and Lock Nuts

#### TORQUE CHARTS

Minimum Hardware Tightening Torques

Normal Assembly Applications  
(Metric Hardware and Lock Nuts)

Nominal Size	Class 5,8		Class 8,8		Class 10,9		Lock nuts
	Unplated or Plated Silver	Plated W / ZnCr Gold	Unplated or Plated Silver	Plated W / ZnCr Gold	Unplated or Plated Silver	Plated W / ZnCr Gold	Class 8 W / CL. 8,8 Bolt
<b>M4</b>	1.7 N•m (15 in.-lb.)	2.2 N•m (19 in.-lb.)	2.6 N•m (23 in.-lb.)	3.4 N•m (30 in.-lb.)	3.7 N•m (33 in.-lb.)	4.8 N•m (42 in.-lb.)	1.8 N•m (16 in.-lb.)
<b>M6</b>	5.8 N•m (51 in.-lb.)	7.6 N•m (67 in.-lb.)	8.9 N•m (79 in.-lb.)	12 N•m (102 in.-lb.)	13 N•m (115 in.-lb.)	17 N•m (150 in.-lb.)	6.3 N•m (56 in.-lb.)
<b>M8</b>	14 N•m (124 in.-lb.)	18 N•m (159 in.-lb.)	22 N•m (195 in.-lb.)	28 N•m (248 in.-lb.)	31 N•m (274 in.-lb.)	40 N•m (354 in.-lb.)	15 N•m (133 in.-lb.)
<b>M10</b>	28 N•m (21 ft.-lb.)	36 N•m (27 ft.-lb.)	43 N•m (32 ft.-lb.)	56 N•m (41 ft.-lb.)	61 N•m (45 ft.-lb.)	79 N•m (58 ft.-lb.)	30 N•m (22 ft.-lb.)
<b>M12</b>	49 N•m (36 ft.-lb.)	63 N•m (46 ft.-lb.)	75 N•m (55 ft.-lb.)	97 N•m (72 ft.-lb.)	107 N•m (79 ft.-lb.)	138 N•m (102 ft.-lb.)	53 N•m (39 ft.-lb.)
<b>M16</b>	121 N•m (89 ft.-lb.)	158 N•m (117 ft.-lb.)	186 N•m (137 ft.-lb.)	240 N•m (177 ft.-lb.)	266 N•m (196 ft.-lb.)	344 N•m (254 ft.-lb.)	131 N•m (97 ft.-lb.)
<b>M20</b>	237 N•m (175 ft.-lb.)	307 N•m (226 ft.-lb.)	375 N•m (277 ft.-lb.)	485 N•m (358 ft.-lb.)	519 N•m (383 ft.-lb.)	671 N•m (495 ft.-lb.)	265 N•m (195 ft.-lb.)
<b>M24</b>	411 N•m (303 ft.-lb.)	531 N•m (392 ft.-lb.)	648 N•m (478 ft.-lb.)	839 N•m (619 ft.-lb.)	897 N•m (662 ft.-lb.)	1160 N•m (855 ft.-lb.)	458 N•m (338 ft.-lb.)

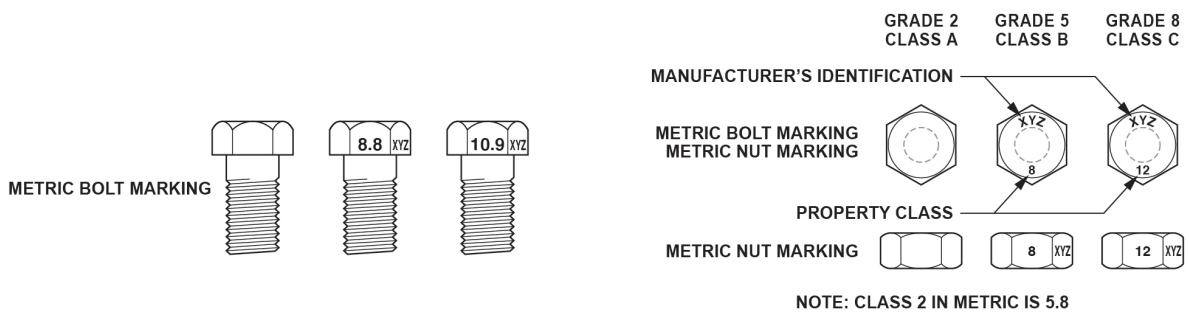



---

[www.loftness.com](http://www.loftness.com)

Loftness Specialized Equipment, Inc.  
650 Main Street South • PO Box 337 • Hector, MN 55342  
Tel: 320.848.6266 • Fax: 320.848.6269 • Toll Free: 1.800.828.7624

Printed in USA  
© Loftness 2026