



GRAIN BAG STORAGE SYSTEMS

Grain Bag Baler

Model BB 10-300

Owner's Manual and Parts Book
(Originating w/Serial Number 87-290)



Model Number: _____
Serial Number: _____
Date of Purchase: _____

LOFTNESS SPECIALIZED EQUIPMENT, INC.

LIMITED WARRANTY POLICY

The limited warranty policy begins upon delivery of the unit to the original customer.

The following Loftness products have a two (2) year limited warranty;

XLB10 Grain Bag Loader, Battle Ax L-series Skid Steer, Battle Ax S-series Skid Steer, Battle Ax H-series Skid Steer, Battle Ax Excavator 20-series, Battle Ax Excavator 30-series, Battle Ax Excavator 40-series, Battle Ax Excavator 50-series, Battle Ax Extreme, Bad Ax Skid Steer, Timber Ax Skid Steer, Stump Ax, BT20, Kwik Cut.

All other Loftness products have a one (1) year limited warranty.

If any Loftness product is used as rental or leased equipment the limited warranty period is for only 30 days from the delivery date to the original customers.

Loftness Specialized Equipment, Inc. ("LOFTNESS") warrants new LOFTNESS machinery and/or attachments at the time of delivery to the original purchaser, to be free from defects in material and workmanship when properly set up and operated in accordance with the recommendations set forth in the LOFTNESS Operator's Manual. The second year of limited warranty includes only parts, and not labor.

LOFTNESS' liability for any defect with respect to accepted goods shall be limited to repairing the goods at an authorized dealer or other LOFTNESS designated location, or replacing them as LOFTNESS shall elect. The above shall be in accordance with LOFTNESS warranty adjustment policies.

WARRANTY REQUIREMENTS

Warranty registration form must be filled out and returned to Loftness Specialized Equipment to validate all warranty claims.

To request a warranty claim, a return authorization from LOFTNESS must be obtained. The failed part may then be returned in an untampered status. This warranty does not include freight or delivery charges incurred when returning machinery for servicing. Dealer mileage, service calls and pick-up/delivery charges are the customer's responsibility.

LIMITATIONS OF WARRANTY

LOFTNESS products are designed to provide years of dependable service when proper use and maintenance is adhered to. The potential for misuse in many applications exists; therefore, a limited warranty is provided as follows.

This warranty shall not apply to any machine or attachment which shall have been repaired or altered outside the LOFTNESS factory or authorized LOFTNESS dealership or in any way so as in LOFTNESS' judgment, to affect its stability or reliability, nor which has been subject to misuse, negligence or accident, nor to any machine or attachment which shall not have been operated in accordance with LOFTNESS' printed instructions or beyond the company recommended machine rated capacity. LOFTNESS may elect to have an area representative evaluate the condition of the machine before warranty is considered.

In addition, this limited warranty provides no coverage for general wear or maintenance items, misuse, environmental conditions and/or contamination for which they were not designed or not intended, including but not limited to the following items;

Use of machine beyond its rated capacity, Conveyors, Improper knife replacement, Auger wear, Missing knives, Saw blades, Striking foreign objects, Brakes and brake pads, Lack of lubrication, Tires, Failures caused by running in an "out-of-balance" condition, Hydraulic hoses damaged by being caught in "pinch points" or by moving parts, and Damage caused by excessive force from the power unit.

EXCLUSIONS OF WARRANTY

Except as otherwise expressly stated herein, LOFTNESS makes no representation or warranty of any kind, expressed or implied. **The implied warranty of merchantability and fitness for a particular purpose are disclaimed, and excluded from this limited warranty.** The remedies set forth in this warranty are the sole and exclusive remedies available to any person under this warranty. LOFTNESS shall have no liability to any person for incidental, consequential or special damages of any description, whether arising out of express or implied warranty or any other contract, negligence, or other tort or otherwise. This exclusion of consequential, incidental and special damages is independent from and shall survive any finding that the exclusive remedy failed of its essential purpose. Upon purchase, the buyer assumes all liability, all personal injury and property damage resulting from the handling, possession or use of the goods by the buyer.

No agent, employee or representative of LOFTNESS has any authority to bind LOFTNESS to any affirmation, representation or warranty concerning its machinery and/or attachments except as specifically set forth herein. (October 2025)

LOFTNESS ™

Table of Contents

Warranty

Table of Contents

Introduction

Owner Information	1
Warranty Policy	1
Serial Number Location	1
Manual Storage	1
Grain Bag Baler Features	2

Safety Instructions

Safety First	3
Owner's Responsibility	3
Safety Rules	4
Operating Safety	4
Transporting Safety (while installed on Grain Bag Unloader)	4
Maintenance Safety	5
Hydraulic Safety	5
PTO Safety	5
California Proposition 65 Warning	5
Safety Decal Locations	6
Grain Bag Baler Identification	8

Installation Instructions

Installing the Bag Baler	9
Overview	9
Moving the Manual Holder/Tool Box	9
Preparing the Grain Bag Unloader and Bag Baler	9
Lifting the Bag Baler	10
Lifting Baler with Forklift	10
Lifting Baler with Hoist	11
Mounting the Bag Baler	11
Securing Hydraulic Hoses	12
Removing Shipping Stands	12

Set-up and Operating Instructions

Connecting Grain Bag Unloader to the Tractor	13
Connecting Bag Baler Hydraulic Hoses	13
Setting Up Baler and Grain Bag Unloader for Bag Baling Operation	13
Winding/Baling Bag	15
Wrapping Bale	17
Removing Bale from Baler	19
Unloading Bale into Truck/Trailer Bed	20
Unloading Bale onto the Ground	20
Returning Baler and Grain Bag Unloader to Storage/Transport Position	20

Table of Contents

Maintenance

General Maintenance	23
Maintenance Schedule	23
Fluids and Lubricants	23
Lubrication.....	23
Grease Points	23
Oiling the Chain.....	24
Bale Spear Chain Inspection and Adjustment.....	25
Baler Spear Chain Inspection	25
Baler Spear Chain Adjustment	26
Troubleshooting.....	27

Parts Identification

Bag Baler.....	30
Hydraulics - Motor	32
Hydraulics - Cylinder.....	32
Hydraulics - Tractor Pressure and Tank	33
Bag Baler Slide (201603).....	34
Bag Baler - Lever and Crank Assemblies	36
Machine Decals and Signs	37

Appendix

Specifications	39
Dimensions	40
Torque Specifications	41
Inches Hardware and Lock Nuts.....	41
Metric Hardware and Lock Nuts	42

Owner Information

Thank you for your decision to purchase a Model BB 10-300 Grain Bag Baler from Loftness. To ensure maximum performance of your machine, it is mandatory that you thoroughly study the owner's manual and follow the recommendations. Proper operation and maintenance are essential to maximize machine life and prevent personal injury.

NOTE: *This manual provides safety, set-up, operation, and maintenance instructions, along with a replacement parts section for the Loftness Grain Bag Baler. There will be some references to operation of the Loftness Grain Bag Unloader within this manual when it pertains to bag winding only. For safety instructions, operation, maintenance, and replacement parts for the grain bag unloader, refer to the Loftness Grain Bag Unloader Owner's Manual.*

The Loftness BB 10-300 Grain Bag Baler is designed to wind and bale emptied bags used for grain storage. The baler will handle bags up to 10 ft. (3.05 m) in diameter with a maximum length of 300 ft. (91.4 m).

Operate and maintain this machine in a safe manner and in accordance with all applicable local, state, and federal codes, regulations and/or laws. Follow all on-product labeling and instructions.

Make sure that all personnel have read this owner's manual and thoroughly understand safe and correct operating, installation and maintenance procedures.

Continuous improvement and advancement of Loftness products may result in changes to your equipment that may not be reflected in this publication. Loftness reserves the right to make product improvements to the machine at any time. Although great care has been taken to ensure the accuracy of this publication, Loftness does not assume any liability for errors or omissions.

Loftness Specialized Equipment, Inc. is not responsible for the condition of the grain when it is being stored in or removed from grain bags loaded or unloaded with Loftness built equipment.

Warranty Policy

Be sure to read and understand the Warranty Policy at the beginning of this manual. It is also important that you fill out the Warranty Registration form(s) completely and return to Loftness so as not to void the warranty.

Serial Number Location

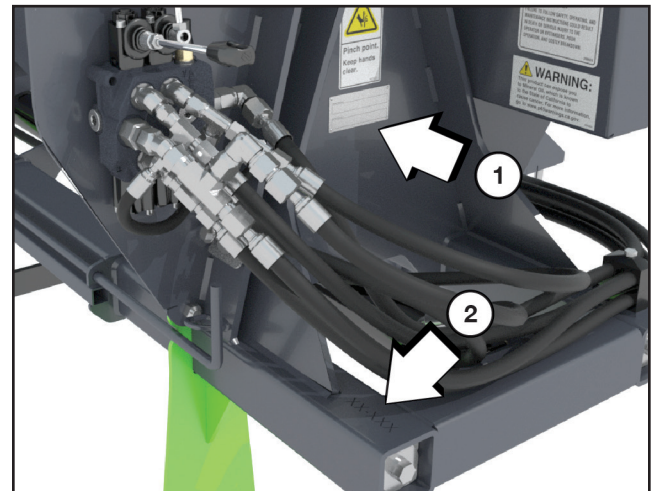

The arrows above indicate the location of the serial number tag (1) and the location of the serial number stamped into the frame (2).

Always use your model and serial number when requesting information or when ordering parts

Manual Storage

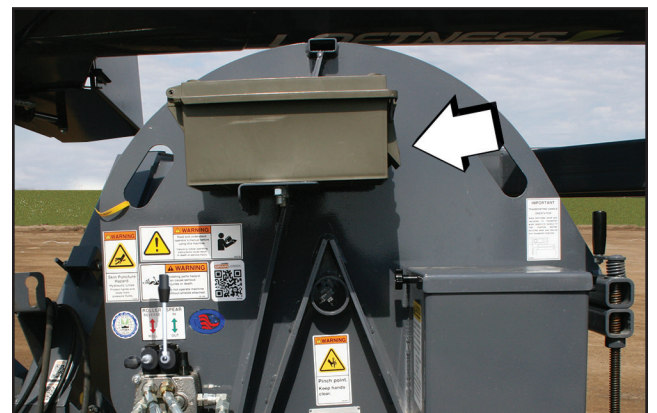

Keep the owner's manual and the entire documentation packet in the storage compartment provided on the grain bag unloader. The owner's manual must be available for all operators.

NOTE: *The manual holder/tool box will be relocated from its current position on the grain bag unloader to the bracket on the bag baler shown above.*

Introduction

Grain Bag Baler Features

- 9- or 10-foot bags up to 300 ft. long.
- Weighs 920 lbs. (417.3 kg).
- Mounts directly onto all new and existing Loftness GBU10 models.
- Simple, easy mounting - no drilling or welding.
- Eliminates need for secondary power source and transport.
- Rolls bags directly off of main bag roller.
- Eliminates unrolling bags onto the ground, and handling loose bags in windy conditions.
- Requires one hydraulic outlet.
- Rugged 3 in. x 3 in. steel tube frame.
- 2-1/2 in. bore x 52 in. stroke hydraulic cylinder.
- Enclosed twine ball holder.
- Sliding twine-wrapping handle.
- Spring-loaded adjustable bag tensioner.
- Hydraulic drive with two-lever control valve.

Safety First

Accidents can be prevented by recognizing the causes or hazards before an accident occurs and doing something about them. Regardless of the care used in the design and construction of this machine, there are some areas that cannot be safeguarded without interfering with accessibility and efficient operation.



Safety Alert Symbol

This message alert symbol identifies important safety messages on the machine and in the owner's manual. When you see this symbol, be alert to the possibility of personal injury and carefully read the message that follows.

In the owner's manual and on decals used on the machine the words **DANGER, WARNING, CAUTION, IMPORTANT, and NOTE** are used to indicate the following:

DANGER: This word warns of immediate hazards which, if not avoided, will result in severe personal injury or death. The color associated with Danger is RED.



WARNING: This word refers to a potentially hazardous situation which, if not avoided, could result in severe personal injury or death. The color associated with Warning is ORANGE.

CAUTION: This word refers to a potentially hazardous or unsafe situation that, if not avoided, may result in minor or moderate injury. It may also be used to alert against unsafe practices. The color associated with Caution is YELLOW.

IMPORTANT: Highlights information that must be heeded.

NOTE: A reminder of other related information that needs to be considered.

If Safety Decals on this machine are ISO two panel pictorial, decals are defined as follows:

- The first panel indicates the nature of the hazard.
- The second panel indicates the appropriate avoidance of the hazard.
- Background color is YELLOW.
- Prohibition symbols such as  and  if used, are RED.

Be certain all machine operators are aware of the dangers indicated by safety decals applied to the machine, and be certain they follow all safety decal instructions. Contact Loftness for safety decal replacement.

Loftness cannot anticipate every possible circumstance that may involve a potential hazard. The warnings in this owner's manual are not all inclusive.

Owner's Responsibility

Operate and maintain this machine in a safe manner and in accordance with all applicable local, state, and federal codes, regulations and/or laws and in compliance with on-product labeling and this owner's manual instructions.

Make sure that all personnel have read this owner's manual, and thoroughly understand safe and correct installation, operation and maintenance procedures.

Make sure the machine is installed correctly before being placed in service. At regular intervals thereafter, the machine should be serviced in accordance with procedures outlined in this owner's manual.

Fulfill all warranty obligations so as not to void the warranties. The warranty policy included in this manual outlines the warranty policy of Loftness.

Safety Instructions

Safety Rules

These are general safety considerations. Additional precautions may be necessary to operate your machine in a safe manner. Be certain you are operating your machine in accordance with all safety codes, OSHA rules and regulations, insurance requirements and local, state, and federal laws.

Operating Safety

- Do not allow anyone to operate the machine until he or she has read the owner's manual and is completely familiar with all safety precautions.
- Do not allow inexperienced persons unfamiliar with the machine, or unfamiliar with safe operating and maintenance procedures, to operate or maintain the machine.
- Do not allow persons under the influence of alcohol, medications, or other drugs that can impair judgment or cause drowsiness to operate or maintain the machine.
- Keep children, bystanders and other workers away from the machine while it is operating. No riders allowed.
- The machine requires an operator at all times. Never leave the machine running and unattended.
- Do not wear loose hanging clothes, neckties or jewelry. Long hair is to be placed under a cap or hat. These precautions will help prevent you from becoming caught in any moving parts on the machine.
- Do wear safety glasses, ear protection, respirators, gloves, hard hats, safety shoes and other protective clothing when required.
- The baler should not be used to handle materials other than those which were specified as part of its design. It is the operator's responsibility to be aware of the specifications and operate the baler accordingly.
- It is the operator's responsibility to be aware of machine operation and work area hazards at all times.
- Never enter the grain bag.
- Operators are responsible to know the location and function of all guards and shields including but not limited to PTO drivelines, gearboxes, chain drives, augers and are responsible to make certain that all guards are in place when operating the machine.
- Operators are responsible to be aware of safety hazard areas and follow instructions on warning, caution, or danger decals applied to the machine.
- Know the area before operating the machine. Be aware of power lines or other equipment. Watch for adequate overhead clearance.
- Always have an operator in the tractor while the machine is in operation.
- Remove from the emptied bag any foreign objects.
- Disengage PTO, clutch hydraulic valve and shift tractor into neutral or park before starting engine.
- Never operate the machine with a 1000 RPM to 540 RPM adapter.

Transporting Safety (while installed on Grain Bag Unloader)

- Be sure the baler, and grain bag unloader, is in the transport position before transporting on a roadway.
- Do not exceed speed rating (20 mph) on the factory provided tires.
- Disengage PTO, clutch hydraulic valve and shift tractor into neutral or park before starting engine.
- Always have safety chains attached.
- Safety precautions for towing with a truck. Machine weight with baler is 6,680 pounds with a 425 lb. hitch weight - hitch weight, mass requires adequate braking.
- Hitch pin size (1-1/8 in. to 1-1/4 in.).
- Ensure tires are in good condition and are inflated to 44 PSI.

Safety Instructions

Safety Rules (Cont'd)

Maintenance Safety

- Do not allow inexperienced persons unfamiliar with the machine, or unfamiliar with safe operating and maintenance procedures, to operate or maintain the machine.
- Do not allow persons under the influence of alcohol, medications, or other drugs that can impair judgment or cause drowsiness to operate or maintain the machine.
- Make sure the operator's area is clear of any distracting objects. Keep work areas clean and free of grease and oil to avoid slipping or falling.
- Periodically check all guards, shields and structural members. Replace or repair anything that could cause a potential hazard.
- Do not replace components or parts with other than factory-recommended service parts. To do so may decrease the effectiveness of the machine.
- Do not lubricate parts while the machine is running.
- Do not smoke while servicing the machine.
- Never attempt to make any adjustments while the tractor engine is running or the key is in the "ON" position in the tractor. Before leaving the operator's position, disengage power to the machine and remove ignition key.

Hydraulic Safety

	WARNING: <i>Contact with high-pressure fluids may cause fluid penetration and burn hazards. Fluid that is under pressure can penetrate body tissue. Fluid penetration can cause serious injury and possible death. If fluid is injected into the skin, seek medical attention immediately!</i>
---	---

- Always wear safety goggles or glasses when working on hydraulic system to avoid eye injury.
- The hydraulic system is under high pressure. Make sure all lines and fittings are tight and in good condition. These fluids escaping under high pressure can have sufficient force to penetrate skin and cause serious injury.

- Never check for leaks by using any part of your body to feel for escaping fluid.
- To prevent serious personal injury from escaping high-pressure fluid, never attempt to inspect, service or disassemble any part of the hydraulic system until all pressure has been relieved from the system.

PTO Safety

- Keep all guards and shields in place when operating the PTO. Replace any damaged or missing guards and shields before operating the PTO.
- Keep children, bystanders and other workers away from the machine while it is operating or while the PTO is engaged. No riders allowed.
- Do not wear loose hanging clothes, neckties or jewelry. Long hair is to be placed under a cap or hat. These precautions will help prevent you from becoming caught in any moving parts on the machine.
- Read and understand the tractor operation and maintenance manual regarding safe and proper operation for PTO driven equipment.
- Never step over or crawl around the equipment while the PTO is engaged; entanglement could occur.
- Do not exceed 540 RPM PTO speed.
- Disengage PTO driveline and place in the stored position when the machine is transported.
- Never use a steel hammer when connecting or disconnecting a PTO shaft.
- Engage and disengage the PTO slowly at idle speed to prevent unnecessary stress to the driveline.
- DO NOT USE PTO ADAPTERS OF ANY KIND.
- Use only recommended shearbolts.

California Proposition 65 Warning

	WARNING: <i>This product can expose you to Mineral Oil, which is known to the State of California to cause cancer. For more information, go to www.p65warnings.ca.gov.</i>
---	---

A decal with this warning statement is adhered to the machine. If the decal should become worn or missing, replace immediately.

Safety Instructions

Safety Decal Locations

Check and replace any worn, torn, hard to read or missing safety decals on your machine.

NOTE: This section shows where safety-related decals are applied on the machine. For all machine decals see “Machine Decals and Signs” on page 37.

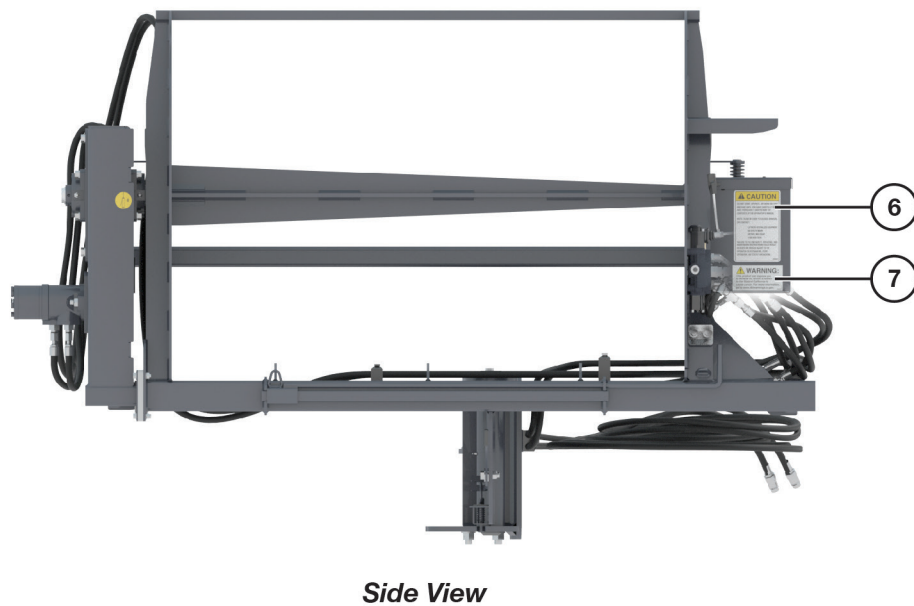
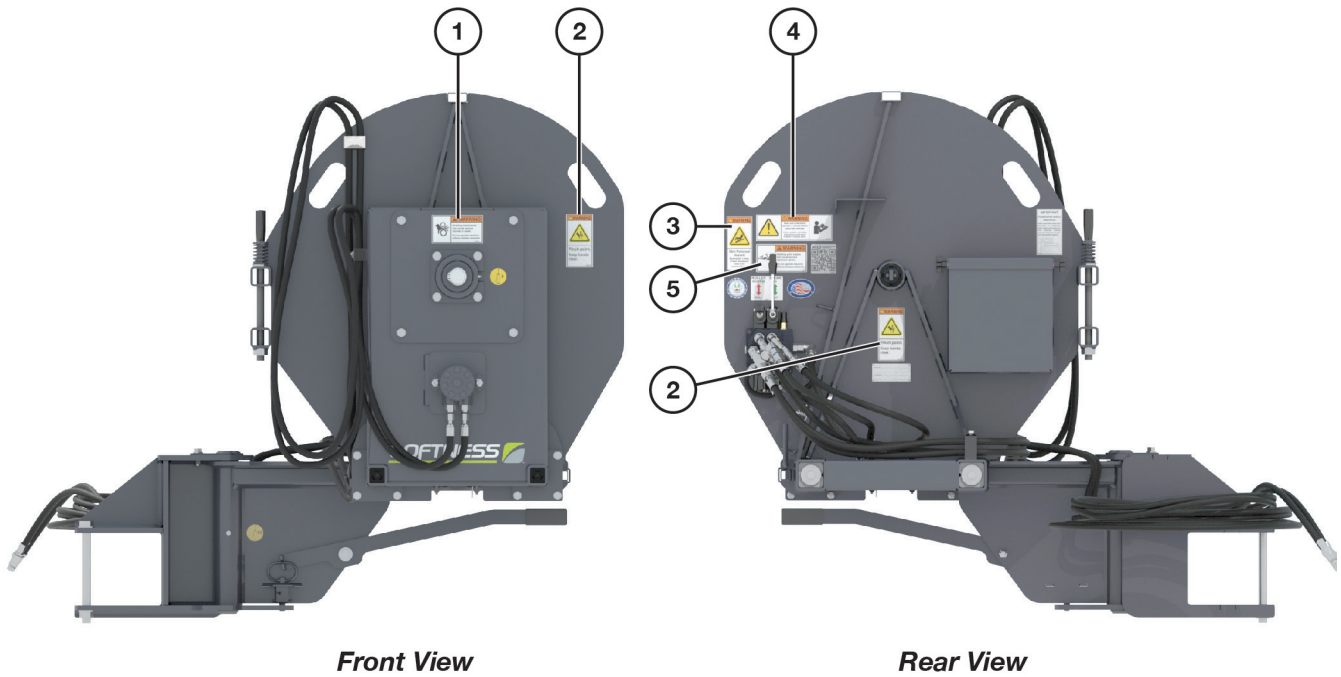

See the following page for detailed images of the safety decals called out above.

Safety Decal Locations (Cont'd)

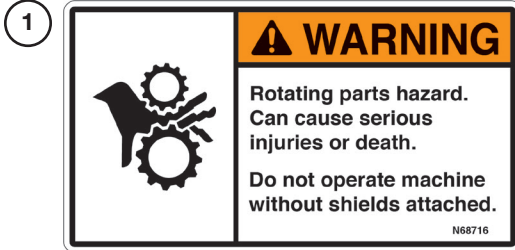

Part No. N68716



Part No. N23507



Part No. N23899



Part No. N22763



Part No. 4189

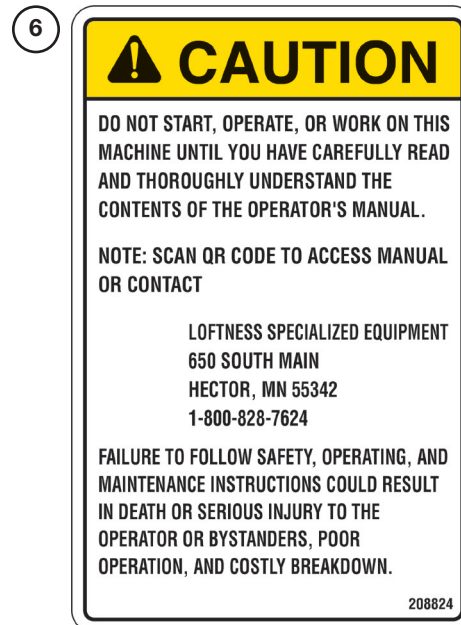

Part No. 208824



Part No. 203264

Safety Instructions

Grain Bag Baler Identification

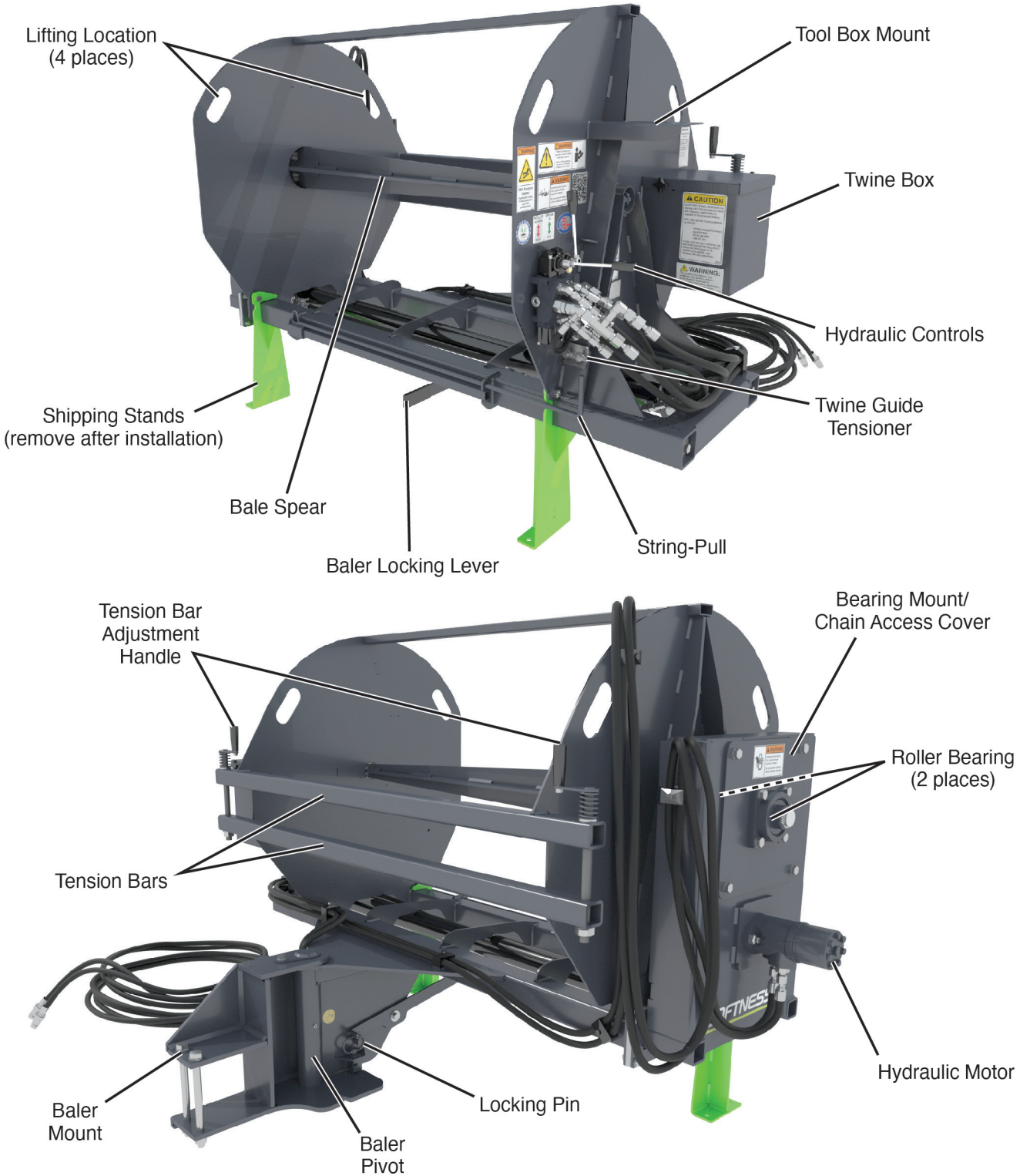

Installation Instructions

Installing the Bag Baler

Overview

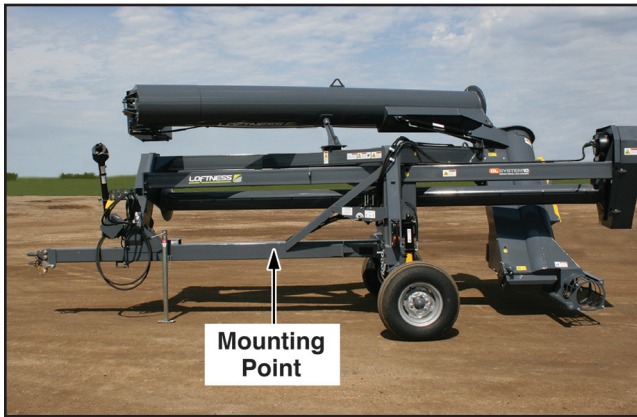

The bag baler will be mounted to the tongue beam on the left side of the grain bag unloader shown above.

The installation of the baler requires two people - a forklift/hoist operator, and a ground worker.

IMPORTANT: Only experienced forklift or hoist operators should lift the bag baler.

Moving the Manual Holder/Tool Box

The manual holder/tool box for the grain bag unloader will need to be moved to allow the bag baler to operate.

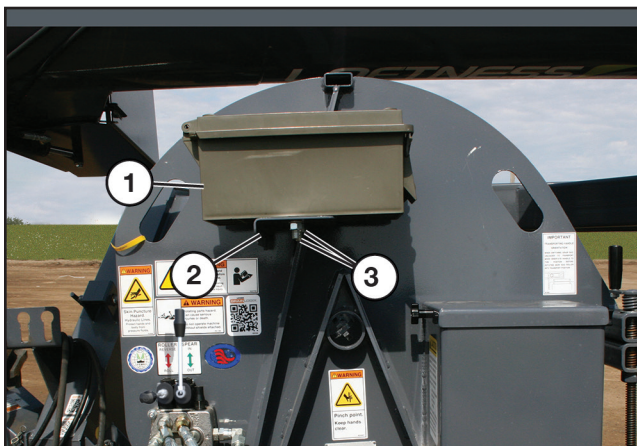

Remove the box from the tongue beam on the grain bag unloader. Move the box (1) to the mounting bracket (2) on the bag baler. Use the existing nuts and bolts (3) to secure.

Preparing the Grain Bag Unloader and Bag Baler

IMPORTANT: Make sure the grain bag unloader frame is level before starting. This will ease the mounting of the baler as it is lifted on to the frame. Use the jack on the tongue of the unloader to level.

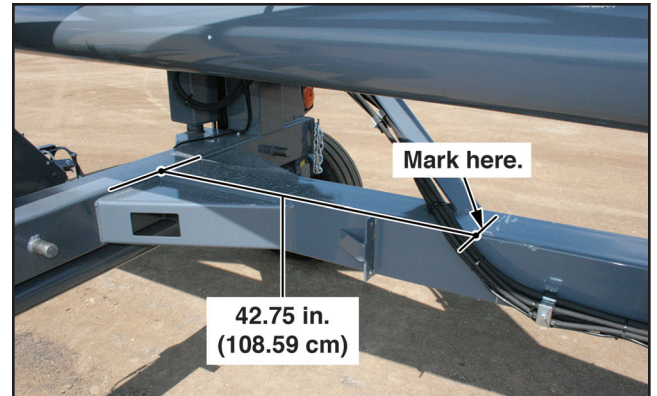

Measure 42.75 in. (108.59 cm) from the location shown above on the grain bag unloader and draw a mark. This is where the back side of the baler mount will be aligned.

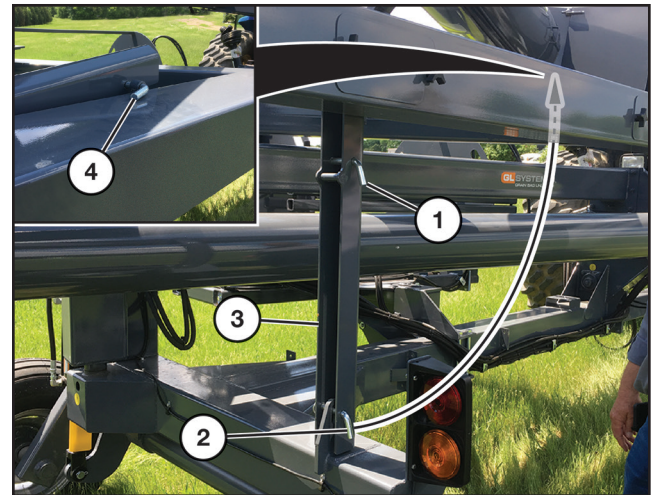

Pull the top pin (1) and bottom pin (2) of the support arm (3).

Swing the support arm up and move into the temporary mounting position (4), and secure with the pin.

(Procedure continued on following page.)

Installation Instructions

Installing the Bag Baler (Cont'd)

Preparing the Grain Bag Unloader and Bag Baler (Cont'd)

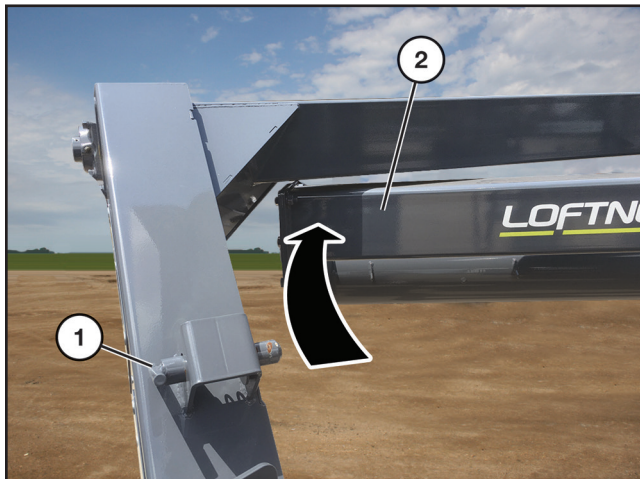

Pull out the spring-loaded locking pin (1) to release the roller.

Swing the roller (2) out and place into field position.

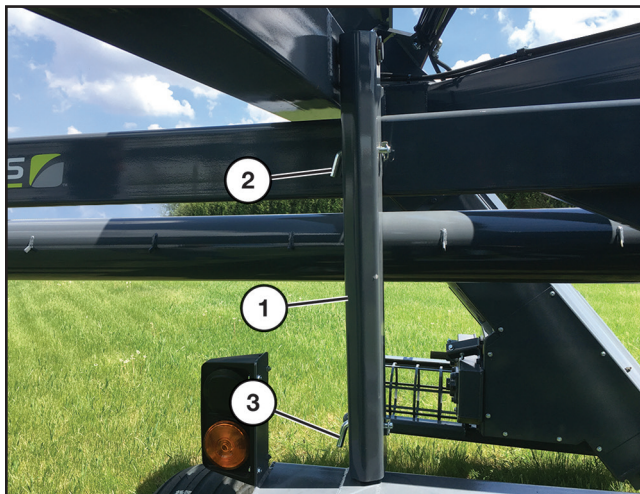

With roller in field position, return the support arm (1) to its original position and insert the top pin (2) and bottom pin (3). Secure pins with the retaining clips.

Lifting the Bag Baler

To lift the baler, use a forklift or power hoist to place the baler onto the grain bag unloader frame.

Use the following instructions, "Lifting Baler with Forklift" or "Lifting Baler with Hoist", for whichever lifting device you will be using.

Common installation procedures will follow these sub-sections.

	<p>DANGER: Crushing Hazard. Failure to safely lift and place the bag baler could result in severe injury or death. Use only a forklift or power hoist that is capable of lifting at least 1,000 lbs. Allow only trained personnel to lift and position the bag baler.</p>
--	--

Lifting Baler with Forklift



Position the forks under the bag baler frame as shown above.

IMPORTANT: Do not extend fork ends more than 8 in. (20.3 cm) past baler frame. More than this amount may result in fork ends hitting parts on the unloader frame when mounting baler.

Lift slowly, checking that the baler is as level as possible.

(Procedure continued on following page.)

Installation Instructions

Installing the Bag Baler (Cont'd)



Connect the baler to the forklift with a chain (1). This will help stabilize the baler and prevent possible tipping during mounting.

Continue with “Mounting the Bag Baler” on the opposite column of this page.

Lifting Baler with Hoist

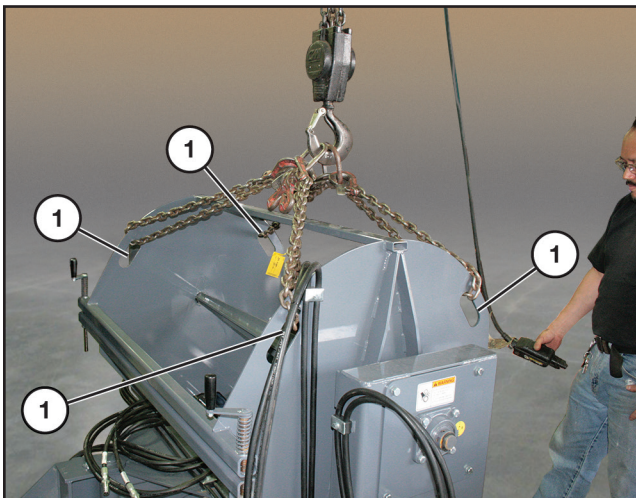

Use the four slotted holes (1) on the ends of the baler to route the hoist chains through as shown above.

Lift slowly, checking that the baler is as level as possible. Use a chain choker hook and make adjustments as necessary to keep the baler level. Ensure the baler mount area remains level and does not point downward.

Continue with “Mounting the Bag Baler” on the opposite column of this page.

Mounting the Bag Baler



Position the ground person on the opposite side of the unloader frame to assist the lifting operator with proper placement.



DANGER: Crushing Hazard. Avoid standing on the same side of the unloader as the baler while it is being mounted. Failure to do so could result in severe injury or death.

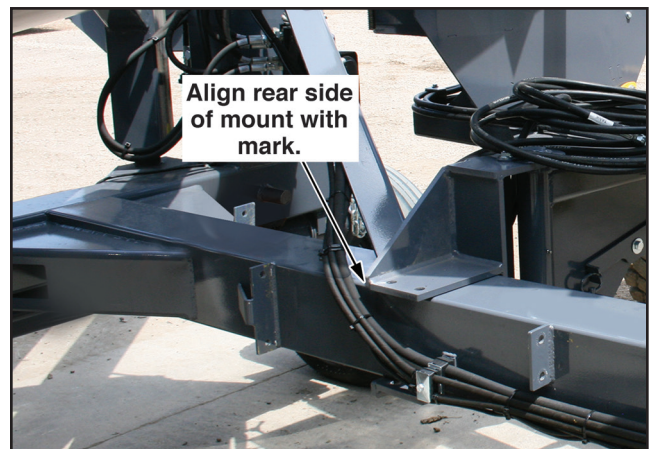

Guide the baler mount onto the unloader frame and position it so the rear side of the baler mount aligns with the mark made earlier (42.75 in. dimension).

(Procedure continued on following page.)

Installation Instructions

Installing the Bag Baler (Cont'd)

Mounting the Bag Baler (Cont'd)

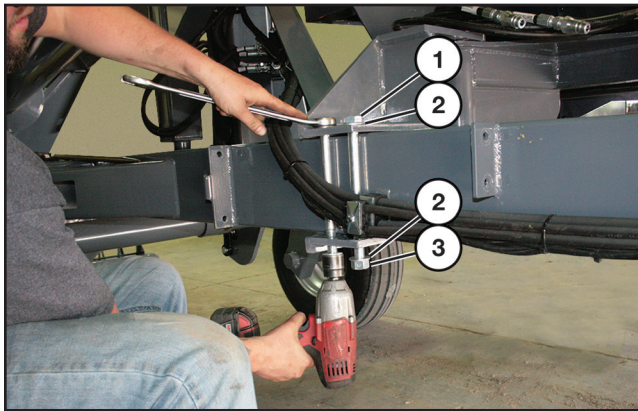

Once in place, insert bolt (1), two washers (2), and nut (3) in the order shown above.

Tighten hardware. Refer to “Torque Specifications” on page 41.

Lifting device(s) can now be removed.

Securing Hydraulic Hoses

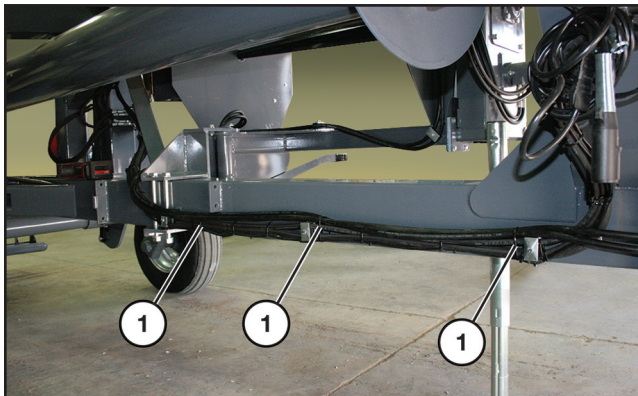

Route the baler’s hydraulic hoses alongside the existing unloader hydraulic lines and secure with zip ties (1) in three places.



Secure the hose ends in the hose holder until ready for operation.

Removing Shipping Stands

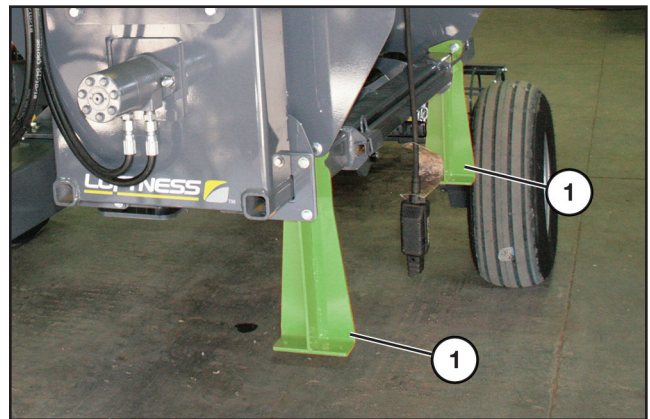

Once the baler is installed and secure, remove the two green shipping (1) stands and attaching hardware.

Set-up and Operating Instructions

Connecting Grain Bag Unloader to the Tractor

The grain bag unloader will likely be set up for bag unloading at this point.

If the grain bag unloader is not connected to the tractor, refer to the directions “Connecting the Grain Bag Unloader” and “Installing Grain Bag Unloader to the Tractor” in the Set-up Instructions section of the grain bag unloader manual for hitch and hydraulic connection instructions.

Connecting Bag Baler Hydraulic Hoses

Remove the bag baler hydraulic hose ends from the hose holder on the unloader and make connections at the tractor.

DO NOT start tractor at this time.

Setting Up Baler and Grain Bag Unloader for Bag Baling Operation

NOTE: Set-up and operation for the bag baler will require at least two people

NOTE: It is not necessary to have the top auger in the operating position to operate the bag baler.

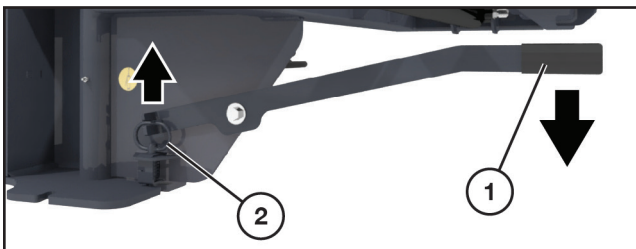

Push the baler locking lever (1) down to release the locking pin (2), allowing the baler to rotate. Swing the baler until it locks into the winding position as shown.

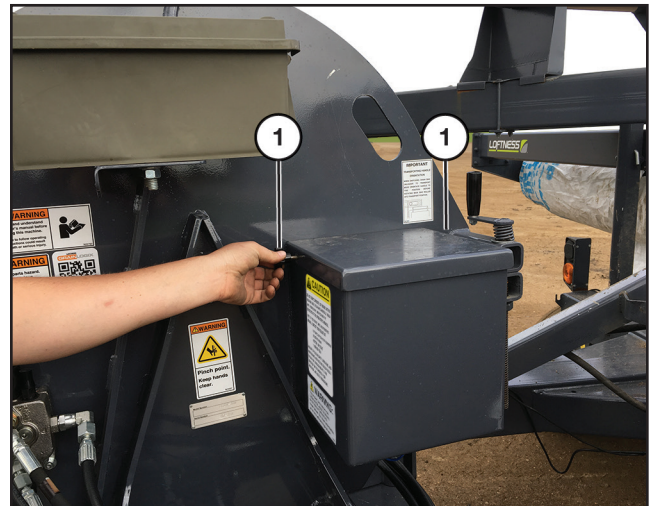

Loosen and remove the two knobs (1) securing the lid to the twine box.



Load the twine roll and pull the spool end through the slot (2) on the side of the twine box.

Replace the cover and knobs.

(Procedure continued on following page.)

Set-up and Operating Instructions

Setting Up Baler and Grain Bag Unloader for Bag Baling Operation (Cont'd)

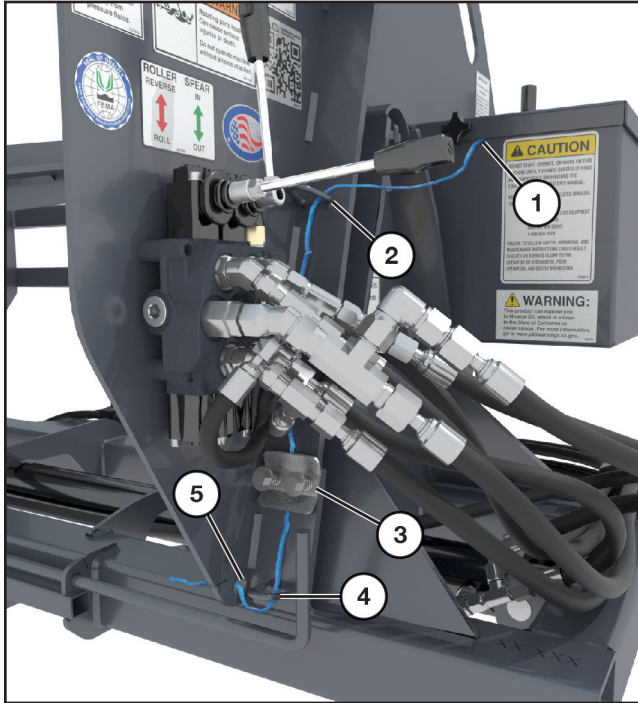

Pull the twine end from the hole in the twine box (1) and guide it through the upper loop (2). Route the twine downward along the gusset, passing it beneath the tensioner plate (3) and through the lower loop (4). Finally, feed the twine end through the hole (5) in the baler frame.

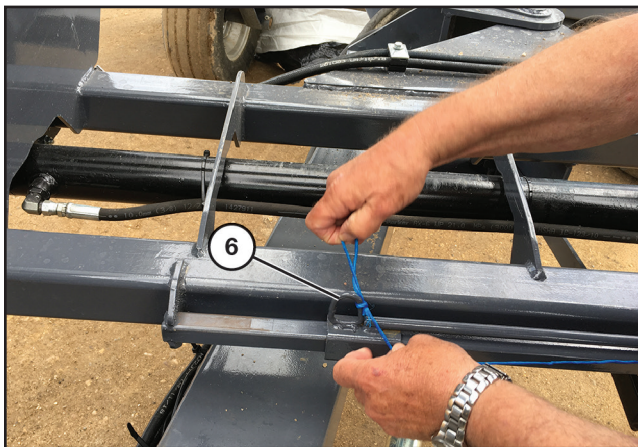

Pull the twine end to the D-ring (6) on the end of the string-pull and tie off with a temporary knot.

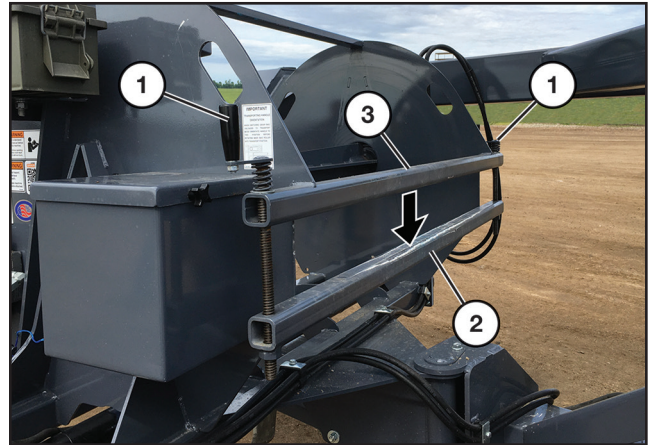

Use the hand cranks (1) to open the spread distance between the lower and upper tension bar (2 and 3).



Release the two latches (1) and open the roller drive door (2).

(Procedure continued on following page.)

Set-up and Operating Instructions

Setting Up Baler and Grain Bag Unloader for Bag Baling Operation (Cont'd)



Pull on the handles to disengage the roller clutch (1) until it locks in the open position. As the baler pulls the bag off of the roller, this allows the roller to “freewheel”.

NOTE: The cogs should rest on the inner cogs.

Close the roller drive door and secure with the two latches

Winding/Baling Bag



Pull the end of the bag through the opening in the frame upright and the support arm on the grain bag unloader.



Feed the bag end through the tension bars, over the bale spear, and to the front of the bag baler.

IMPORTANT: Make sure the bag material fills the entire width of the area between the tension bars.

Make sure all ground workers are standing away from the tractor and unloader/baler.

Start the tractor and engage the hydraulics.

	WARNING: Always have an operator in the tractor while the machine is in operation.
--	---

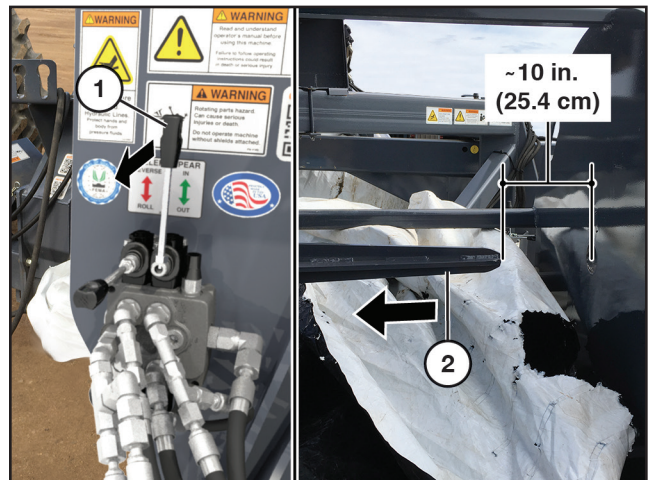

Pull the spear control lever (1) OUT on the control valve to slide the bale spear (2) OUT approximately 10 in. (25.4 cm).

(Procedure continued on following page.)

Set-up and Operating Instructions

Winding/Baling Bag (Cont'd)



Secure the corner/end of the bag to the spear end as shown.

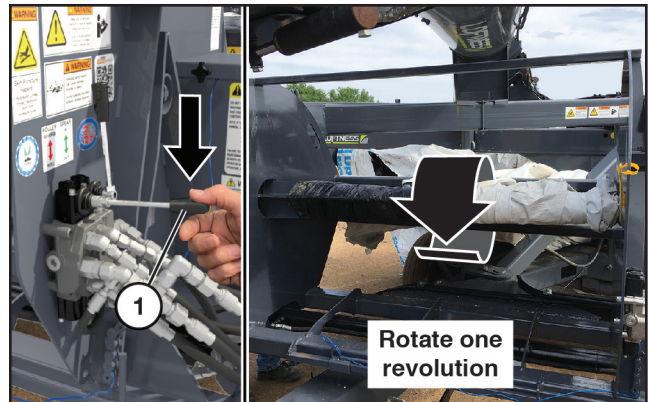

Push the roller control lever (1) **DOWN** on the control valve to **ROLL** the bag end around the spear one revolution.

Release the lever and stop.

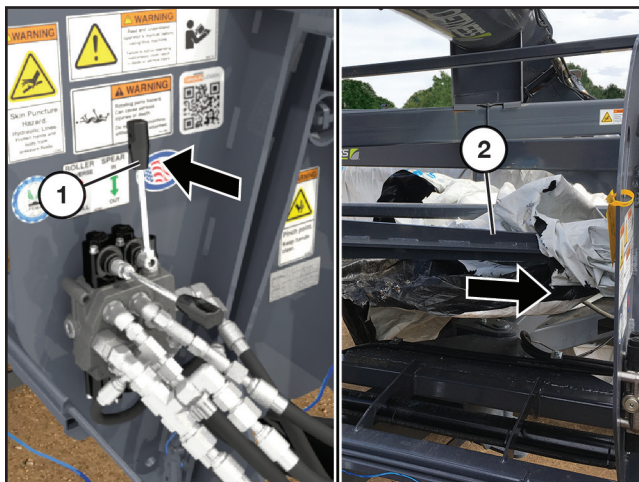

Push the spear control lever (1) **IN** on the control valve to bring the spear (2) back **IN** completely.

	<p>WARNING: Pinch Point. Keep hands clear of the bale spear as it returns back into winding position.</p>
--	--

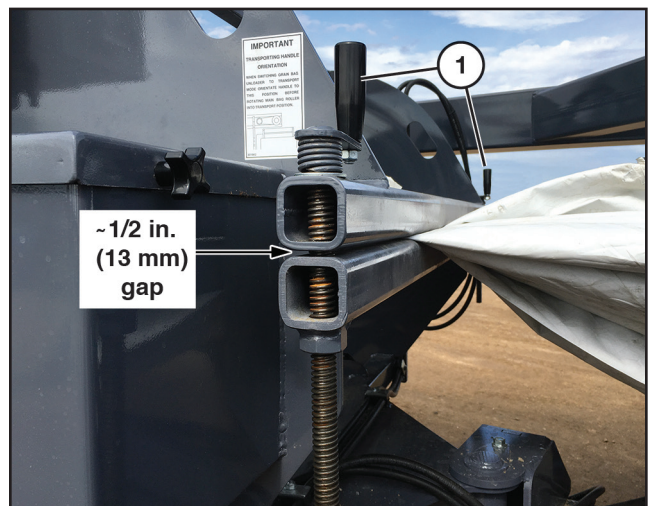

Adjust the hand cranks (1) evenly and close the gap between the tension bars until they are about 1/2 in. (13 mm) apart.

IMPORTANT: Grain adhering to the bag can make it difficult to wind a full 300 ft. bag into a single bale. To help with this problem open up the tension bars to 3/4 in. to allow the sticking grain to pass through and then wind 150 ft. onto the spear.

NOTE: This provides tension on the bag during winding, ensuring it is wrapped tightly on the baling spear.

(Procedure continued on following page.)

Set-up and Operating Instructions

Winding/Baling Bag (Cont'd)



Push DOWN and hold the roller control lever (1) on the control valve to ROLL the entire bag onto the spear.

IMPORTANT: Watch for foreign objects such as sticks, wire, rocks, etc. that may have become trapped or entangled in the grain bag. If any debris is present, stop winding and remove.



Release the ROLL control lever to STOP winding when there is about 18 in. (45.7 cm) remaining. This allows for enough bag material to be tied to the baling twine.

Wrapping Bale



Slide the string-pull (1) out from baler frame until the D-ring (2) reaches the end.

Untie the temporary knot made earlier and route the baling twine through the D-ring as shown.



Tie the end of the twine to the outside corner of the bag with a secure knot.

(Procedure continued on following page.)

Set-up and Operating Instructions

Wrapping Bale (Cont'd)

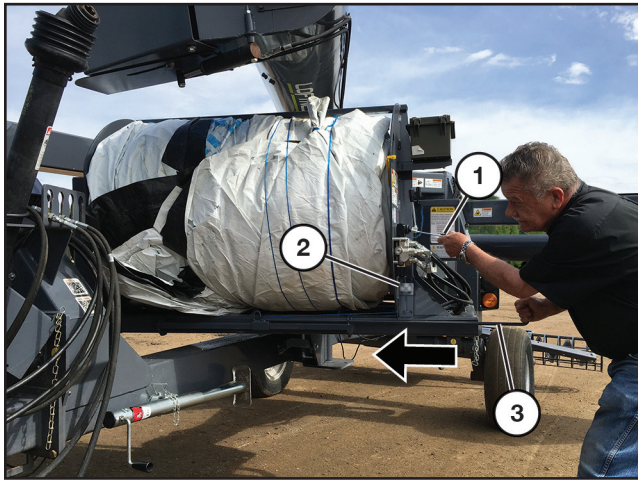

Push DOWN and hold the roller control lever (1) on the control valve to begin wrapping the twine around the bale.

NOTE: *The twine should pass through the twine tensioner (2) with a slight amount of tension. If it appears too loose or too tight, adjust the two nuts on the twine tensioner as needed.*

After one full revolution of the bale, slowly begin sliding the string-pull (3) IN as the twine wraps around the bale.

IMPORTANT: *Push the string-pull at a steady, even pace to ensure that the twine wraps the bag securely.*



Release the control lever and stop wrapping when the bag-to-twine knot (1) is just above the D-ring.



Pull some extra twine and cut.

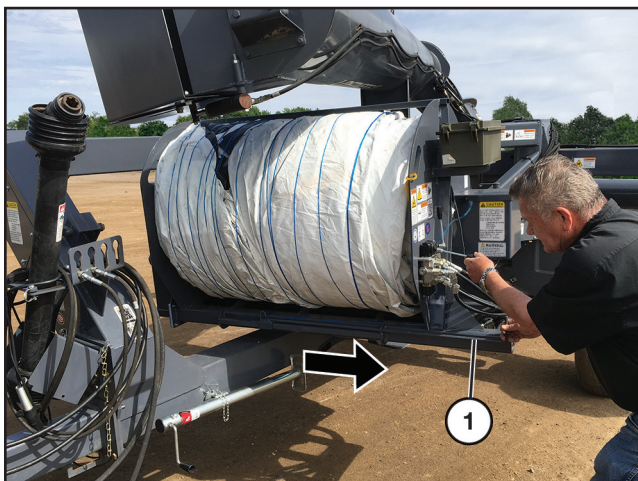

When the twine reaches the far end of the bale, slowly pull the string-pull (1) back at the same pace until the D-ring reaches the end.



Tie the end of the twine to the bag-to-twine knot (1) made earlier. Make sure all knots are secure.

(Procedure continued on following page.)

Set-up and Operating Instructions

Wrapping Bale (Cont'd)

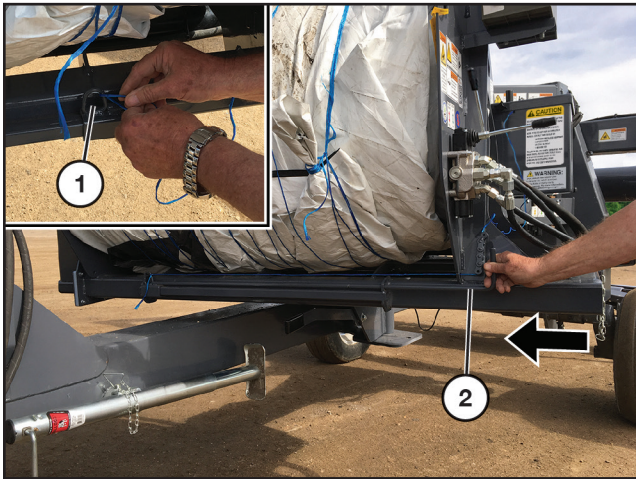

Tie off the twine end from the spool onto the D-ring (1) with a temporary knot and push string-pull (2) back in.



Push the lever (1) down to release and unlock the baler position. Rotate the baler back and lock into the storage position.

Removing Bale from Baler

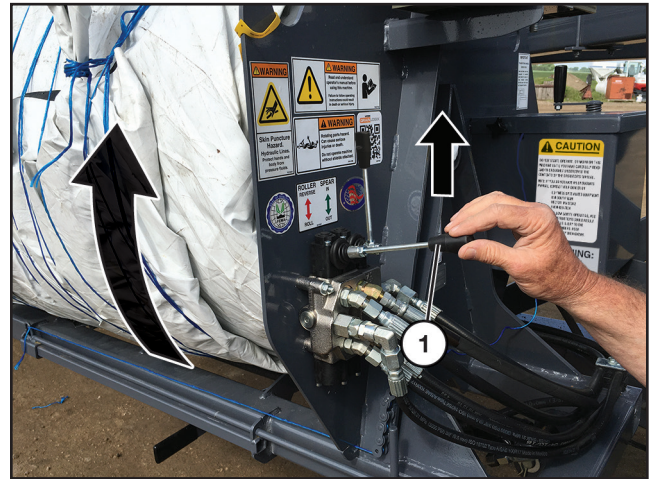

Once in the storage/unloading position, lift UP and hold the roller control lever (1) to REVERSE the wrapped bale. Rotate one revolution, then release lever.

NOTE: This releases bag tension caused when winding the bag on to the baling spear, allowing the spear to be pulled out from the bale easier.

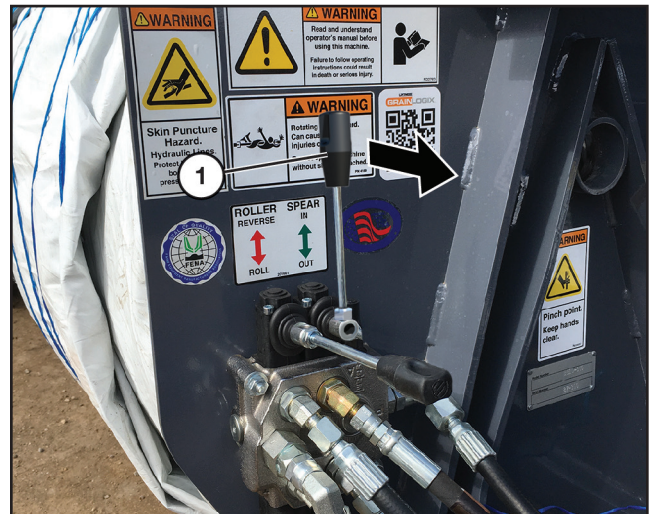

Pull OUT and hold the spear control lever (1) on the control valve to pull the baling spear OUT of the bale.

(Procedure continued on following page.)

Set-up and Operating Instructions

Removing Bale from Baler (Cont'd)



Release the lever when the spear is completely out of the bale.

Unloading Bale into Truck/Trailer Bed



Lower the tailgate and back the truck or trailer up to the bag baler. Carefully pull the bag off the baler and onto the truck or trailer bed.



CAUTION: A bag bale can weigh up to 500 lbs. (227 kg). Use caution when removing.

Unloading Bale onto the Ground

With extreme caution, the bag bale can be pulled off of the baler and dropped onto the ground and be left to retrieve later.



WARNING: Crushing Hazard. A baled bag can weigh up to 500 lbs. (227 kg). Failure to safely and cautiously remove bag from baler could result in serious injury or death.

Returning Baler and Grain Bag Unloader to Storage/Transport Position



Push IN and hold the spear control lever (1) on the control valve to return the spear back into the baler frame.

Turn tractor off.

(Procedure continued on following page.)

Returning Baler and Grain Bag Unloader to Storage/Transport Position (Cont'd)



Release the two latches (1) and open the roller drive door (2).

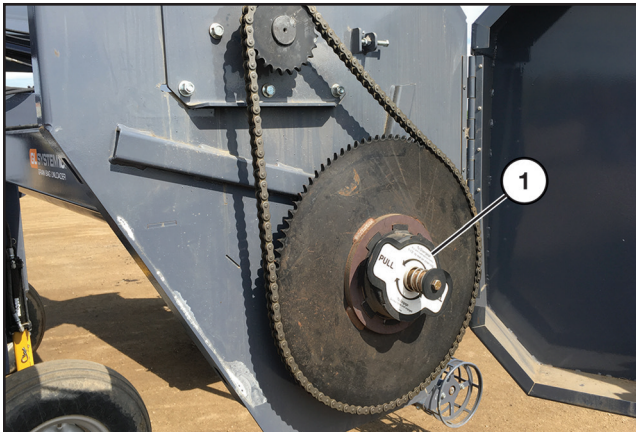

Re-engage the clutch (1) by quickly rotating in either direction and snapping back into place.

Close the roller drive door and secure with the latches.

NOTE: *If more grain bags are to be unloaded, push the baler locking lever down and move the bag baler into the winding position for easier access to the grain bag unloader hydraulic controls. Make sure the baler is in locked position.*



General Maintenance

See “Maintenance Safety” on page 5 before performing any service or maintenance on the grain bag baler.

	WARNING: Always shut down the tractor, remove the ignition key, set the park brake and remove the PTO shaft from the tractor before performing any inspections or maintenance.
--	---

To ensure efficient operation, you should inspect, lubricate, and make necessary adjustments and repairs at regular intervals. Parts that are starting to show wear should be ordered ahead of time, before a costly breakdown occurs and you have to wait for replacement parts. Keep good maintenance records and adequately clean your baler/unloader after each use.

NOTE: Lubricate chains at the end of the day while the chains are warm from operating.

Maintenance Schedule

H O U R S	SERVICE POINTS	SERVICE REQUIRED					P A G E #
		C H E C K	G R E A S E	O I L	C H A N G E	A D J U S T	
Every 8	Outside Spear Bearing		X				X
	Inside Spear Bearing		X				X
Every 100	Baler Pivot		X				X
	Spear Chain			X			X

Fluids and Lubricants

	CAUTION: Use proper safety procedures when handling petroleum products including, but not limited to, the use of rubber gloves and eye protection.
--	---

Proper lubrication is important. Too little lubricant will cause premature failure of a bearing. Too much lubrication usually causes high operating temperature and early failure of seals. Follow all lubrication instructions and schedules included in this section.

1. Grease - Use an SAE multipurpose high temperature grease with extreme-pressure (EP) rating. Also acceptable is an SAE multipurpose lithium based grease.
2. Chain - Use 80W-90 gear lube.
3. Storing Lubricants - Your machine can operate at top efficiency only if clean lubricants are used. Use clean containers to handle all lubricants. Store them in an area protected from dust, moisture and other contaminants.

Lubrication

Grease Points

	DANGER: Shut down power from the tractor before lubricating.
--	---

NOTE: Replace any broken or missing grease fittings. Be sure to clean fittings before greasing.

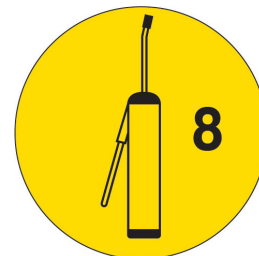

NOTE: Lubricate the grease point every “X” hours indicated on the decal adjacent to the grease point.

(Procedure continued on following page.)

Maintenance

Lubrication (Cont'd)

Grease Points (Cont'd)

See "Grain Bag Baler Identification" on page 8 for component location and identification.

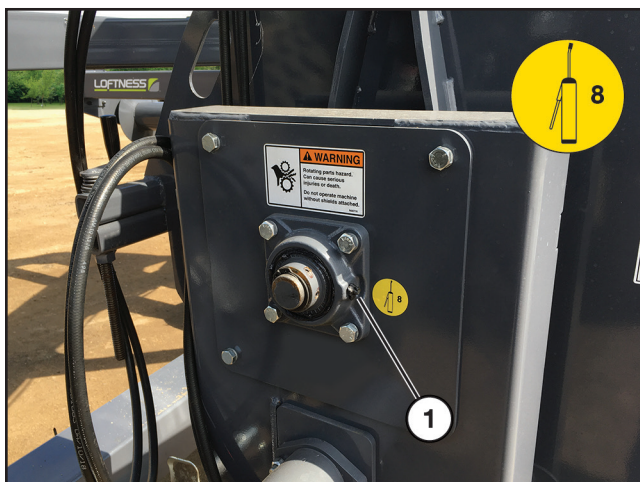

Location: Outside spear bearing (1).
Interval: Every 8 hours of operation.

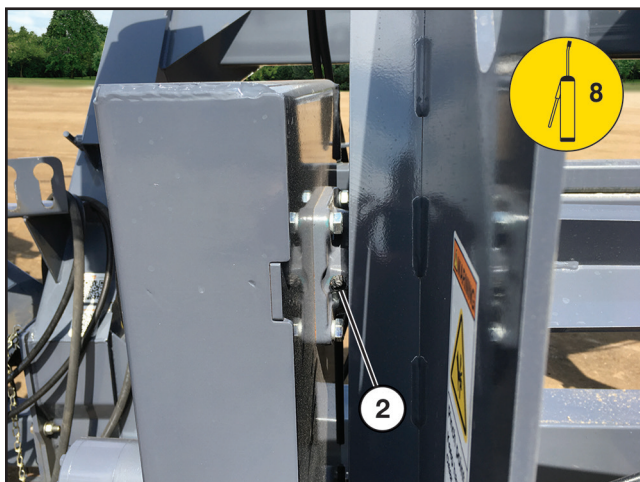

Location: Inside spear bearing (2).
Interval: Every 8 hours of operation.



Location: Baler pivot bushing (3).
Interval: Every 100 hours of operation.

Oiling the Chain

NOTE: Hydraulic power is required to slide the baler spear out, providing access to the cover plate and chain.

Start the tractor and engage the hydraulics.

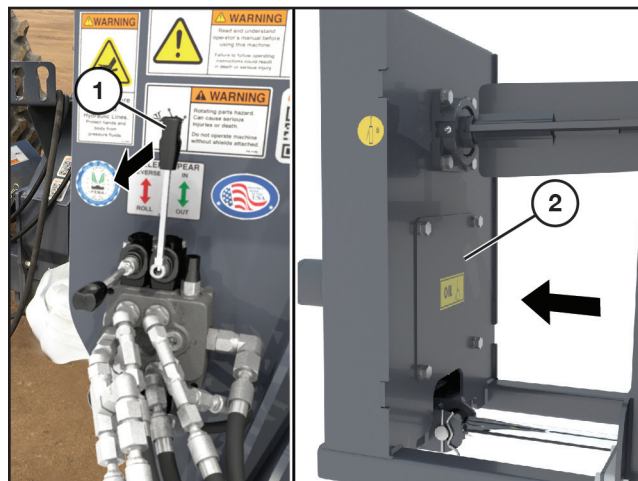

Pull the spear control lever (1) OUT on the control valve to slide the bale spear weldment far enough out to allow removal of the cover plate (2) and lubricate the chain.

Shut off the tractor to remove power from the baler.

(Procedure continued on following page.)

Lubrication (Cont'd)

Oiling the Chain (Cont'd)

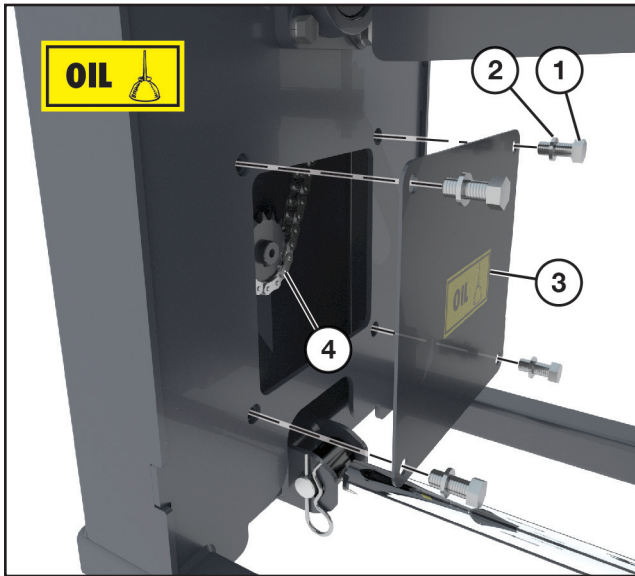

Remove the four bolts (1) and washers (2), then remove the cover plate (3).

Lubricate the chain (4) thoroughly using 80W-90 gear lubricant every 100 hours of operation.

Reinstall the cover plate and secure it with the bolts and washers after lubrication is complete.

Start the tractor and engage the hydraulics. Operate the control lever on the control valve to return the bale spear to the operating position. After completing the procedure, shut off the tractor.

Bale Spear Chain Inspection and Adjustment



WARNING: Never attempt to make any adjustments while the tractor engine is running or the key is in the "ON" position in the tractor. Before leaving the operator's position, disengage power to the machine and remove ignition key.

Baler Spear Chain Inspection

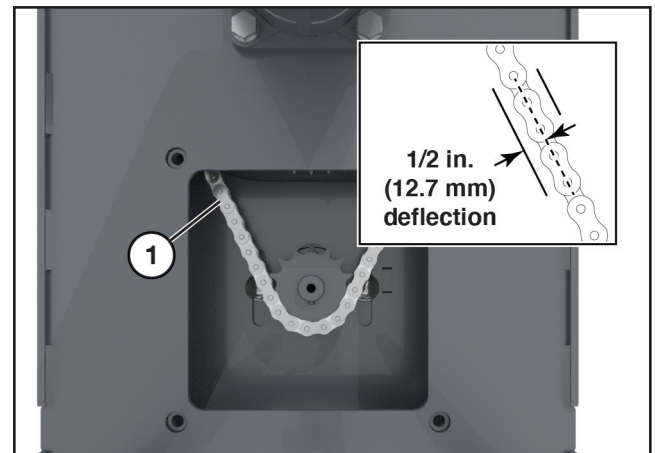

To access the baler spear chain, remove the cover plate. Refer to "Oiling the Chain" on page 24 for instructions on cover plate removal.

To check chain deflection, press on the chain at location (1) between the two sprockets. The chain should deflect approximately 1/2 in. (12.7 mm).

If chain deflection exceeds 1 in. (25.4 mm), refer to "Baler Spear Chain Adjustment" on page 26 for adjustment instructions.

If no adjustment is required, reinstall the cover plate and secure it with the original hardware.

Maintenance

Bale Spear Chain Inspection and Adjustment (Cont'd)

Baler Spear Chain Adjustment

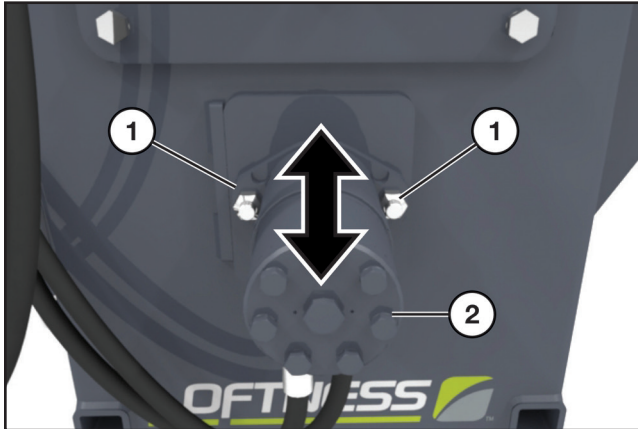

To adjust chain deflection, loosen the two nuts (1) securing the motor (2). Slide the motor up or down until the deflection is approximately 1/2 in. (12.7 mm).

NOTE: *Do not overtighten the chains. Overtightening will put undue stress on the chains and other components of the roller/spear drive.*

Once the correct deflection is set, reinstall the two nuts and tighten.

Return the plug to the chain access hole.

Troubleshooting

To assist with maintenance and repair, the following list of common problems and corrections is provided.

PROBLEM	CAUSE	SOLUTION
Spear not turning.	Chain not engaged or broken.	Verify chain engagement. Tighten chain. Replace chain.
	Hydraulic hoses not connected to tractor.	Connect hoses.
Remote hydraulic controls not functioning correctly.	Hydraulic hoses not installed correctly.	Reverse hydraulic hoses at tractor.
	Hydraulic couplers not opening.	Replace couplers.
Bag will not wrap around spear. Spear stalling.	Tension too tight.	Decrease tension.
Bag not fitting on roller.	Tension too loose.	Increase tension.
	Grain sticking to bag.	Open up tension bars to 3/4 in. to allow sticking grain to pass through and then wind 150 ft. onto spear.
Bag not wrapping around spear evenly.	Tension not set correctly.	Adjust tension.
Bag will not release from spear.	Bag caught on spear.	Reengage spear completely and reverse spear rotation 1 to 2 revolutions.





PARTS IDENTIFICATION

Parts Identification

Bag Baler

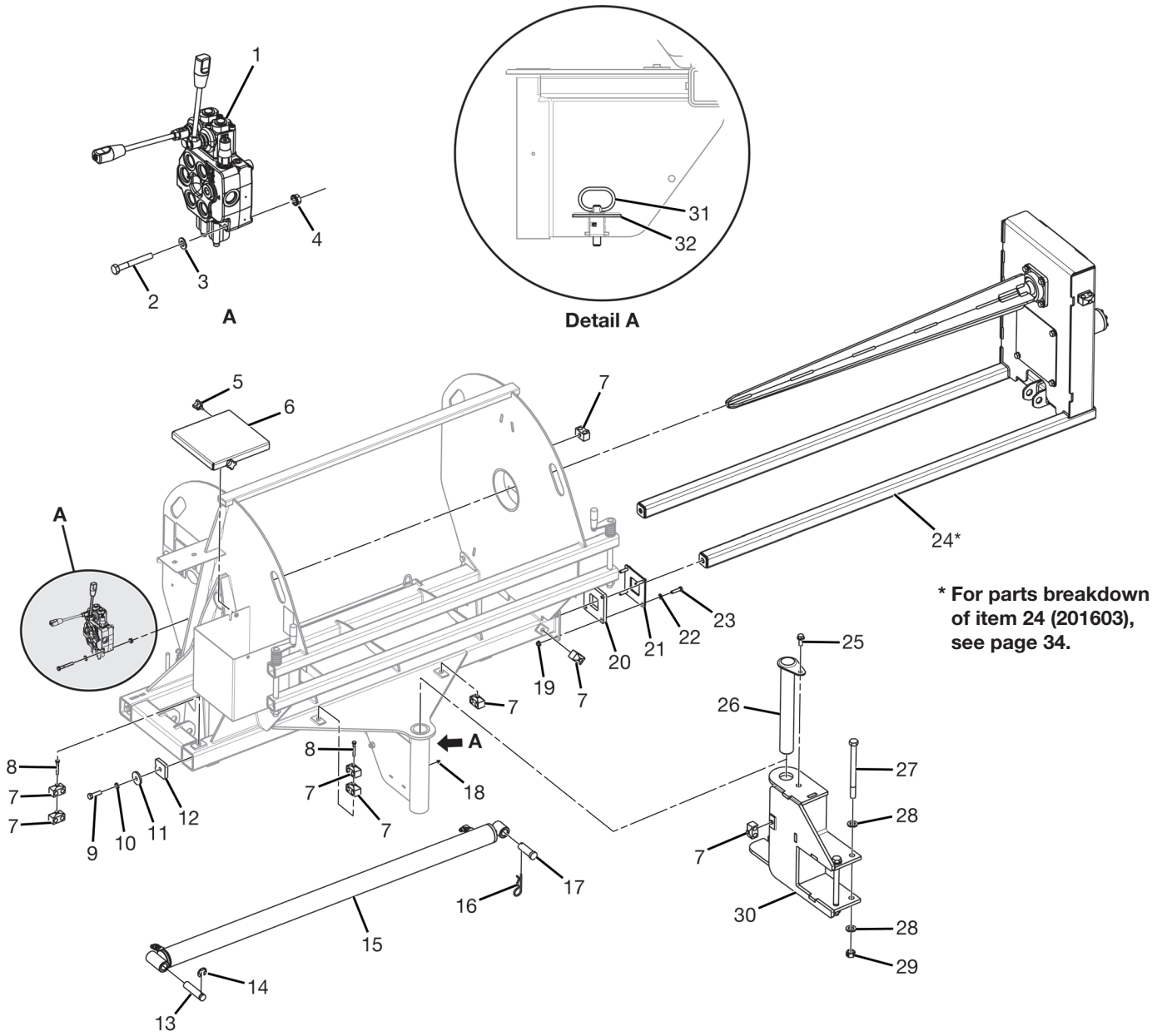

Parts Identification

Bag Baler

#	QTY.	PART #	DESCRIPTION
1	1	201285	VALVE, 2-SECTION MONO
2	2	4204	BOLT, 5/16" X 2-1/2" GRADE 5
3	2	N28927	WASHER, FLAT 5/16 SAE
4	2	N26742	NUT, LOCK 5/16" SER FLG
5	2	N17502	KNOB, 1/4" X 3/4" FOUR PRONG
6	1	201665	PLATE, TWINE BOX COVER
7	8	N21365	CLAMP, 3/8" DOUBLE HOSE
8	2	N28436	BOLT, 5/16" X 2-1/4" GR5
9	2	4014	BOLT, 1/2" X 1-3/4" GRADE 5
10	2	4155	WASHER, LOCK 1/2"
11	2	4074	WASHER, 2" OD X 1/2" ID X 1/4"
12	2	201029	PLATE, BAG ROLLER GUIDE 2
13	1	201701	PIN, BAG BALER
14	1	201702	RING, RETAINING SIDE MOUNT EX
15	1	N154782	CYLINDER, 2.5 X 52
16	1	4389	CLIP, HAIRPIN 3/16" X 3"
17	1	4315	PIN, 1" X 2-1/2"
18	1	4105	GREASE-ZERK, 1/4" SCREW-IN
19	8	4979	NUT, LOCK 3/8" SER FLG
20	2	201028	PLATE, BAG ROLLER GUIDE 1
21	2	201030	PLATE, BAG ROLLER GUIDE 3
22	8	N31741	WASHER, FLAT 3/8" SAE
23	8	4006	BOLT, 3/8" X 1-1/2" GRADE 5
24	1	201603	SLIDE, BAG ROLLER
25	1	N18360	BOLT, 1/2"-13 X 1-1/4 SER FLG
26	1	201043	PIN, BAG ROLLER
27	2	201065	BOLT, 3/4"-10 X 9-1/2" GR 5
28	4	N35327	WASHER, FLAT 3/4" SAE
29	2	4056	NUT, LOCK 3/4"
30	1	201606	MOUNT, BAG ROLLER FRAME
31	1	201654	LATCH, WELD-ON SPRING LATCH
32	1	201783	PLATE, BAG ROLLER LATCH GUSSET

Parts Identification

Hydraulics - Motor

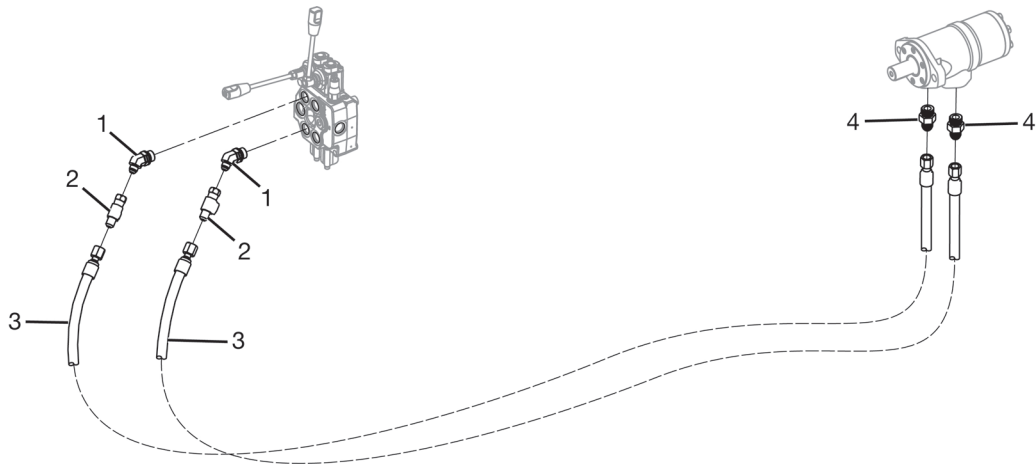

#	QTY.	PART #	DESCRIPTION
1	2	N27928	ELBOW, 45 DEG - 6MJC - 8MOR
2	2	202198	ADAPTER, 6MJIC - 6FJIC - 4FOR
3	2	201083	HOSE, 3/8" X 234" -6FJIC -6FJIC
4	2	N28826	ADAPTER, 6MJIC - 10MOR

Hydraulics - Cylinder

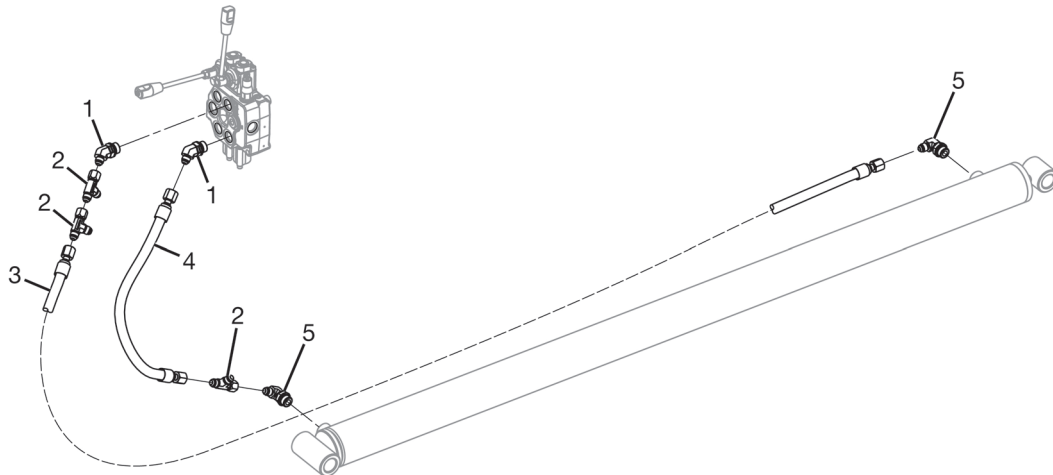

#	QTY.	PART #	DESCRIPTION
1	2	N27928	ELBOW, 45 DEG - 6MJC - 8MOR
2	3	N37279	TEE, -6MJIC-6FJIC-6MJIC
3	1	N29039	HOSE, 3/8" X 80" -6FJIC -6FJIC
4	1	N26319	HOSE, 3/8" X 18" -6FJX -6FJX
5	2	N20037	ELBOW, 90 DEG - 6MJIC - 8MOR

Hydraulics - Tractor Pressure and Tank

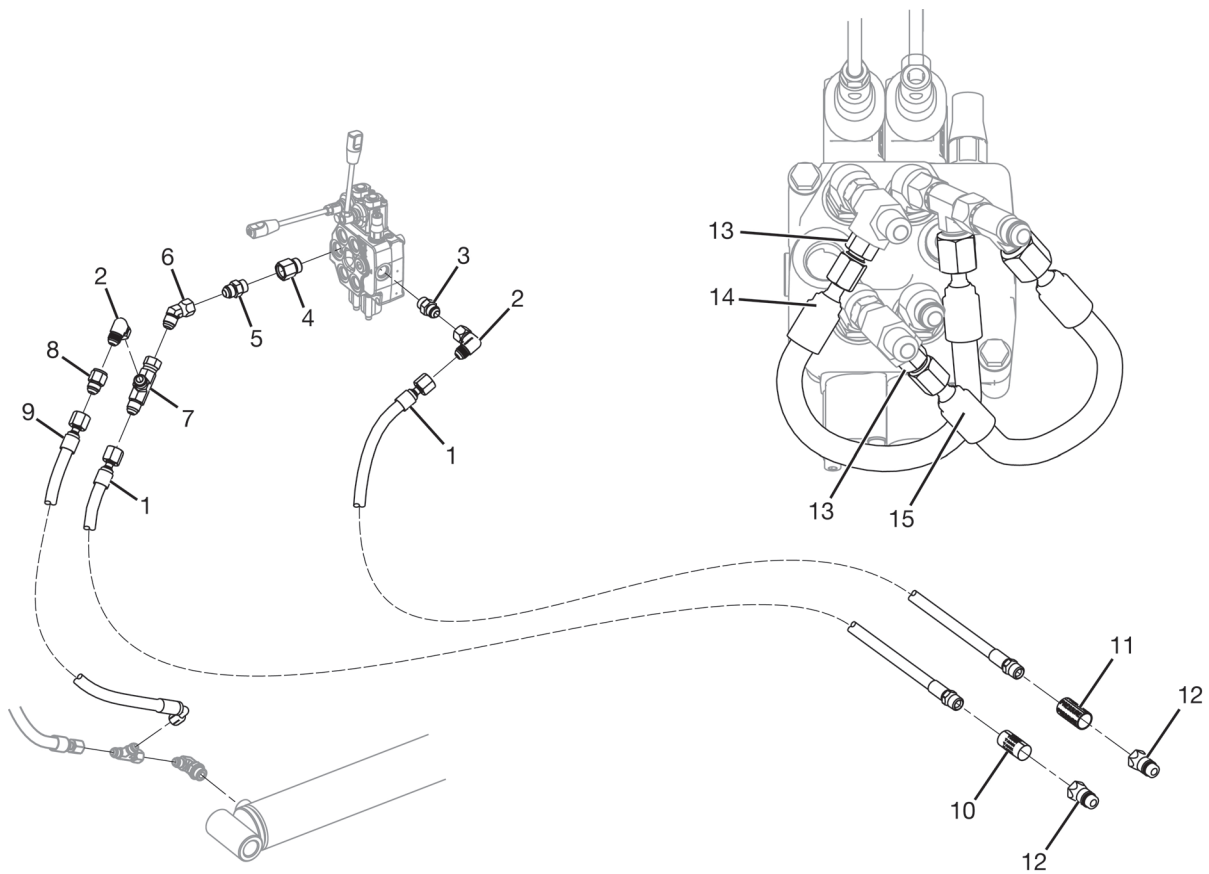

#	QTY.	PART #	DESCRIPTION
1	2	N32577	HOSE, 3/8" X 276" 8FJ1C-8MP
2	2	N24827	ELBOW, 90 DEG - 8FJC - 8MJC
3	1	N20228	ADAPTER, 8MJC - 8MOR
4	1	N23446	ADAPTER, 10MOR - 8FOR
5	1	N23447	VALVE, 5 PSI CHECK 8MOR - 8MJC
6	1	N28838	ELBOW, 45 DEG - 8MJIC -8FJIC
7	1	N20549	TEE, 8MJIC-8FJIC-8MJIC SWVL
8	1	202199	ADAPTER, 8FJIC -8MJIC .062 OR
9	1	202293	HOSE, 3/8" X 20" -8FJX -6FJX90
10	1	N24823	DECAL, TANK
11	1	N24822	DECAL, PRESSURE
12	2	N11825	COUPLER, 1/2" MALE PIONEER
13	2	202310	VALVE, 5 PSI CHECK 4MOR - 4MJC
14	1	202289	HOSE, 1/4" X 11.75" -6FJX -4FJX
15	1	202291	HOSE, 1/4" X 9.75" -6FJX -4FJX

Parts Identification

Bag Baler Slide (201603)

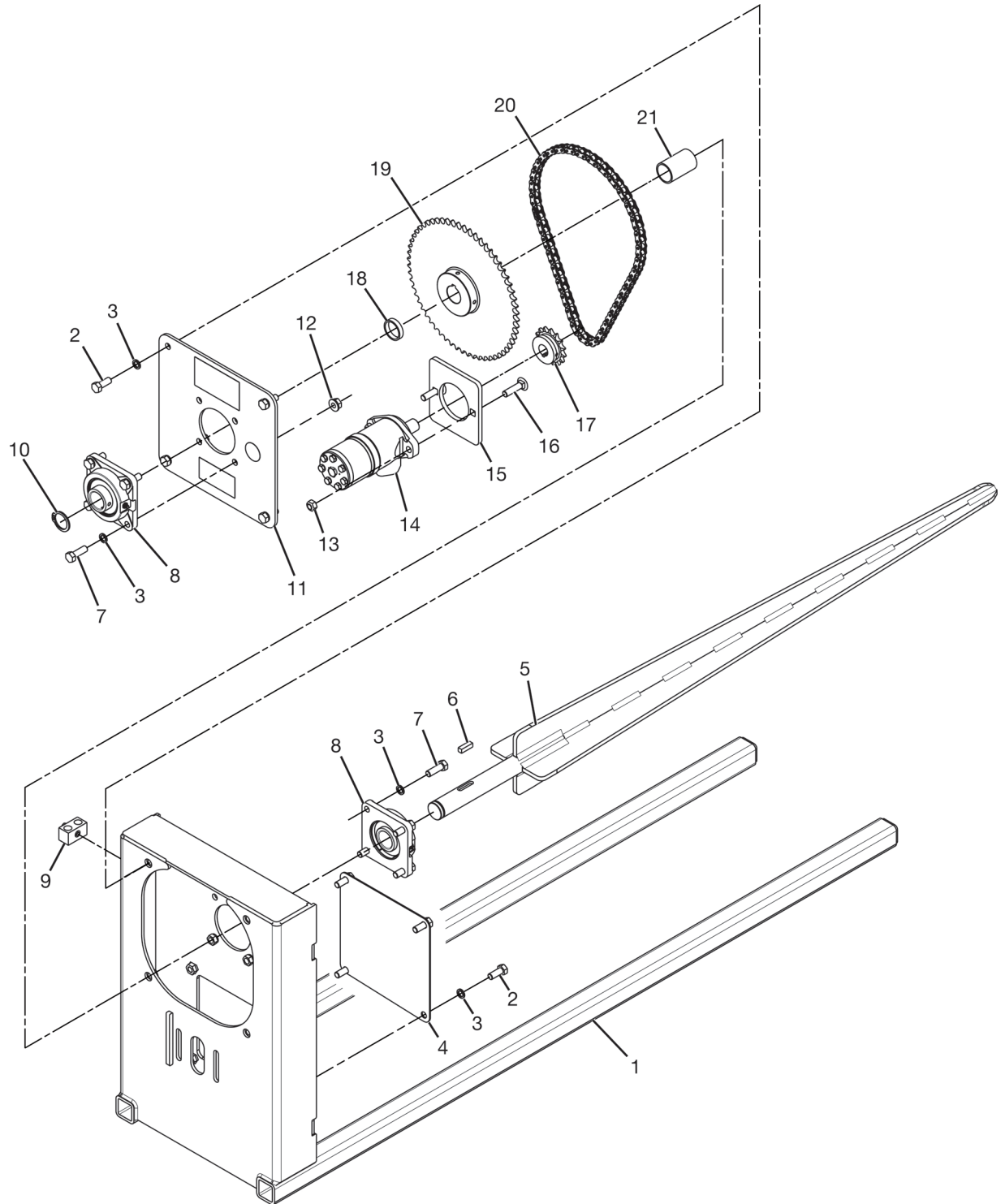

Parts Identification

Bag Baler Slide (201603)

#	QTY.	PART #	DESCRIPTION
1	1	201604	WELDMENT, BAG ROLLER SLIDE
2	8	4012	BOLT, 1/2" X 1-1/4" GRADE 5
3	16	4155	WASHER, LOCK 1/2"
4	1	217160	PLATE, ACCESS DOOR
5	1	201628	SPEAR, BAG ROLLER BAG SPEAR
6	1	201070	KEY, 3/8" X 1-1/4"
7	8	4013	BOLT, 1/2" X 1-1/2" GRADE 5
8	2	N30229	BEARING, 1-1/2" DODGE 4-BLT FLG
9	1	N21365	CLAMP, 3/8" DOUBLE HOSE
10	1	N35331	RING, SNAP EXT 1.5" SHAFT HEAVY
11	1	201631	MOUNT, BAG ROLLER BEARING
12	4	N29075	NUT, LOCK 1/2" SERRATED FLANGE
13	2	4054	NUT, LOCK 1/2" TOP
14	1	N157773	MOTOR, 23.6 CI LSHT
15	1	201071	PLATE, BAG ROLLER MOTOR 1
16	2	4524	BOLT, CARRIAGE 1/2" X 2"
17	1	N26077	SPROCKET, 15 x 50; 1" BORE
18	1	201703	SPACER, BAG ROLLER SPEAR 3/8"L
19	1	201289	SPROCKET, 50B60 1.500 BORE
20	1	201624	CHAIN, #50 X 74 PITCH
21	1	201632	SPACER, BAG ROLLER SPEAR

Parts Identification

Bag Baler - Lever and Crank Assemblies

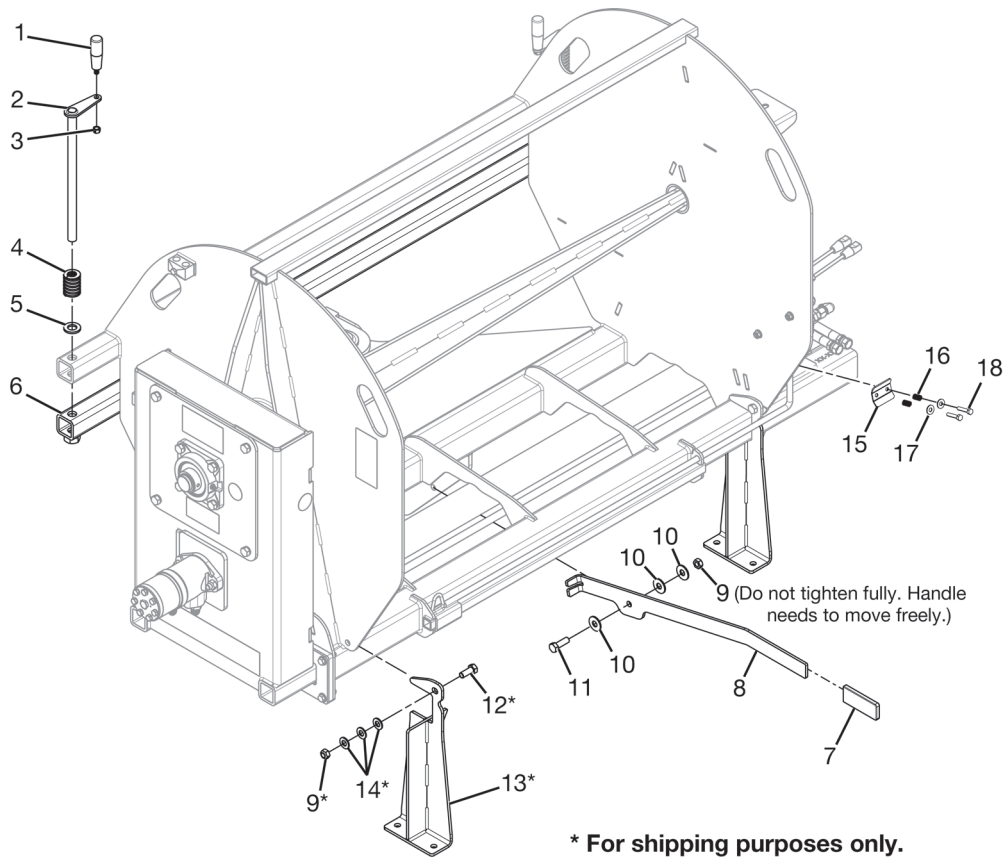

* For shipping purposes only.

#	QTY.	PART #	DESCRIPTION
1	2	201642	HANDLE, 3/8-16X3-1/8 REVOLVING
2	2	201644	BOLT, BAG ROLLER HANDLE
3	2	4052	NUT, LOCK 3/8"
4	2	201705	SPRING, HIGH-STRENGTH DIE 2"
5	2	N35327	WASHER, FLAT 3/4" SAE
6	1	201621	BAR, BAG ROLLER LOWER TENSION
7	1	N50757	COVER, PLASTIC HANDLE
8	1	201650	PLATE, BAG ROLLER HANDLE
9	3	4054	NUT, LOCK 1/2" TOP
10	3	4486	WASHER, 1/2" FLAT
11	1	4013	BOLT, 1/2" X 1-1/2" GRADE 5
12	2	4012	BOLT, 1/2" X 1-1/4" GRADE 5
13	2	201659	STAND, BAG ROLLER SHIPPING
14	6	4068	WASHER, 1/2" SAE FLAT
15	1	215001	PLATE, TWINE TENSIONER B
16	2	215002	SPRING, .50OD .062W .75FL
17	2	4369	WASHER, 5/16" FLAT
18	2	4241	BOLT, 5/16" X 1-1/2" GRADE 5

Machine Decals and Signs

NOTE: All safety related decals are also shown in the Safety Instructions section along with their location on the machine. See "Safety Decal Locations" on page 6.

Check and replace any worn, torn, hard to read or missing decals on your machine.

Part No. N68716

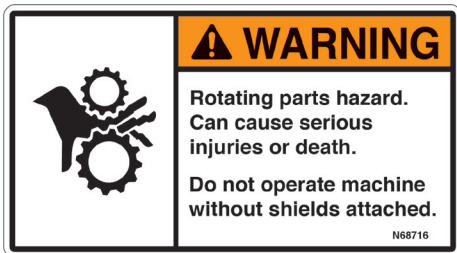

Part No. N23507



Part No. N23899



Part No. N22763



Part No. 4189

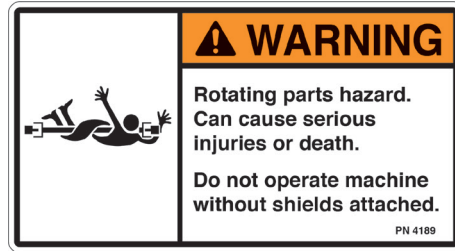

Part No. 208824



Part No. 203264



Part No. 201661

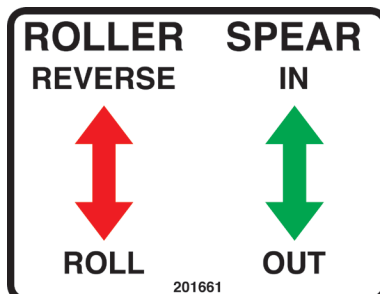

Parts Identification

Machine Decals and Signs (Cont'd)

Part No. 201662

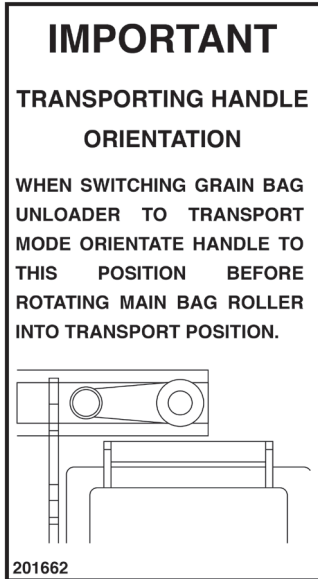

Part No. N28010

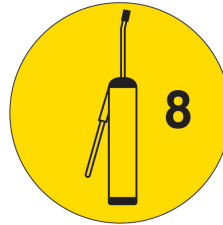

Part No. N28013

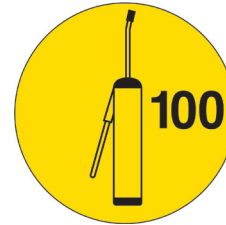

Part No. N13721



Part No. N24822

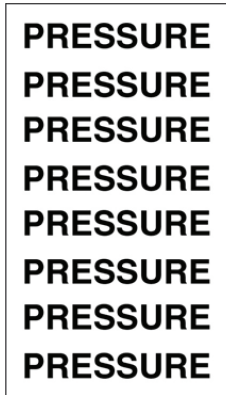

Part No. N24823



Part No. 4138



Part No. N13517



Part No. 4136



Part No. 209528



Part No. N26974 (Horizontal Small)



Specifications

DESCRIPTION	MODEL BB 10-300 GRAIN BAG BALER
Bag Baling Capacity	9 ft. or 10 ft. bags up to 300 ft. long
Bag Baler Control	Hydraulic
Bag Baler Lock	Latch Mechanism
Weight	920 lbs. (417.3 kg)

Appendix

Dimensions

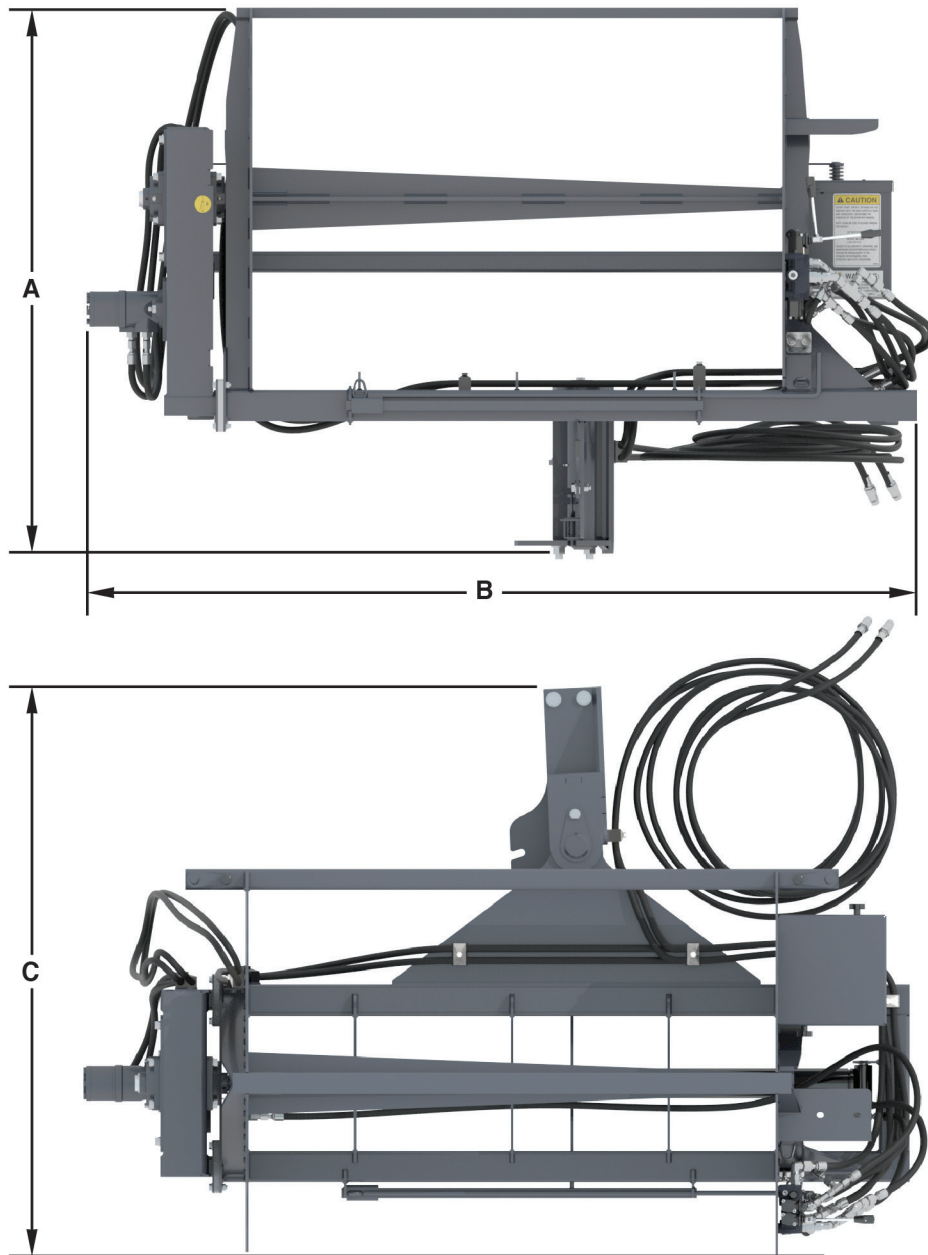

DESCRIPTION		MODEL BB 10-300 GRAIN BAG BALER
Height (A)		51.47 in. (130,7 cm)
Width (B)	Slide Retracted	78.42 in. (199,19 cm)
	Slide Extended	130.42 in. (331,27 cm)
Length (C)		53.96 in. (137,06 cm)
Weight		947 lbs. (429.6 kg)

Torque Specifications

Inches Hardware and Lock Nuts

TORQUE CHARTS

Minimum Hardware Tightening Torques

Normal Assembly Applications
(Standard Hardware and Lock Nuts)

SAE Gr. 2	SAE Grade 5		SAE Grade 8		LOCK NUTS			
	Unplated or Plated Silver	Plated W / ZnCr Gold	Unplated or Plated Silver	Plated W / ZnCr Gold	Unplated or Plated Silver	Plated W / ZnCr Gold	Grade W / Gr. 5 Bolt	Grade W / Gr. 8 Bolt
1/4	55 in.-lb. (6.2 N•m)	72 in.-lb. (8.1 N•m)	86 in.-lb. (9.7 N•m)	112 in.-lb. (12.6 N•m)	121 in.-lb. (13.6 N•m)	157 in.-lb. (17.7 N•m)	61 in.-lb. (6.9 N•m)	86 in.-lb. (9.8 N•m)
5/16	115 in.-lb. (13 N•m)	149 in.-lb. (17 N•m)	178 in.-lb. (20 N•m)	229 in.-lb. (26 N•m)	250 in.-lb. (28 N•m)	324 in.-lb. (37 N•m)	125 in.-lb. (14 N•m)	176 in.-lb. (20 N•m)
3/8	17 ft.-lb. (23 N•m)	22 ft.-lb. (30 N•m)	26 ft.-lb. (35 N•m)	34 ft.-lb. (46 N•m)	37 ft.-lb. (50 N•m)	48 ft.-lb. (65 N•m)	19 ft.-lb. (26 N•m)	26 ft.-lb. (35 N•m)
7/16	27 ft.-lb. (37 N•m)	35 ft.-lb. (47 N•m)	42 ft.-lb. (57 N•m)	54 ft.-lb. (73 N•m)	59 ft.-lb. (80 N•m)	77 ft.-lb. (104 N•m)	30 ft.-lb. (41 N•m)	42 ft.-lb. (57 N•m)
1/2	42 ft.-lb. (57 N•m)	54 ft.-lb. (73 N•m)	64 ft.-lb. (87 N•m)	83 ft.-lb. (113 N•m)	91 ft.-lb. (123 N•m)	117 ft.-lb. (159 N•m)	45 ft.-lb. (61 N•m)	64 ft.-lb. (88 N•m)
9/16	60 ft.-lb. (81 N•m)	77 ft.-lb. (104 N•m)	92 ft.-lb. (125 N•m)	120 ft.-lb. (163 N•m)	130 ft.-lb. (176 N•m)	169 ft.-lb. (229 N•m)	65 ft.-lb. (88 N•m)	92 ft.-lb. (125 N•m)
5/8	83 ft.-lb. (112 N•m)	107 ft.-lb. (145 N•m)	128 ft.-lb. (174 N•m)	165 ft.-lb. (224 N•m)	180 ft.-lb. (244 N•m)	233 ft.-lb. (316 N•m)	90 ft.-lb. (122 N•m)	127 ft.-lb. (172 N•m)
3/4	146 ft.-lb. (198 N•m)	189 ft.-lb. (256 N•m)	226 ft.-lb. (306 N•m)	293 ft.-lb. (397 N•m)	319 ft.-lb. (432 N•m)	413 ft.-lb. (560 N•m)	160 ft.-lb. (217 N•m)	226 ft.-lb. (306 N•m)
7/8	142 ft.-lb. (193 N•m)	183 ft.-lb. (248 N•m)	365 ft.-lb. (495 N•m)	473 ft.-lb. (641 N•m)	515 ft.-lb. (698 N•m)	667 ft.-lb. (904 N•m)	258 ft.-lb. (350 N•m)	364 ft.-lb. (494 N•m)
1	213 ft.-lb. (289 N•m)	275 ft.-lb. (373 N•m)	547 ft.-lb. (742 N•m)	708 ft.-lb. (960 N•m)	773 ft.-lb. (1048 N•m)	1000 ft.-lb. (1356 N•m)	386 ft.-lb. (523 N•m)	545 ft.-lb. (739 N•m)

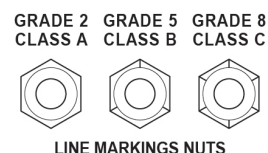
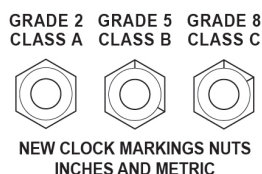
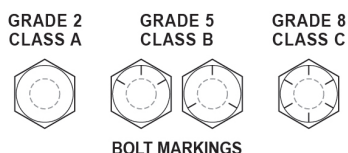

Appendix

Torque Specifications (Cont'd)

Metric Hardware and Lock Nuts

TORQUE CHARTS Minimum Hardware Tightening Torques Normal Assembly Applications (Metric Hardware and Lock Nuts)

Nominal Size	Class 5,8		Class 8,8		Class 10,9		Lock nuts Class 8 W / CL. 8,8 Bolt
	Unplated or Plated Silver	Plated W / ZnCr Gold	Unplated or Plated Silver	Plated W / ZnCr Gold	Unplated or Plated Silver	Plated W / ZnCr Gold	
M4	1.7 N•m (15 in.-lb.)	2.2 N•m (19 in.-lb.)	2.6 N•m (23 in.-lb.)	3.4 N•m (30 in.-lb.)	3.7 N•m (33 in.-lb.)	4.8 N•m (42 in.-lb.)	1.8 N•m (16 in.-lb.)
M6	5.8 N•m (51 in.-lb.)	7.6 N•m (67 in.-lb.)	8.9 N•m (79 in.-lb.)	12 N•m (102 in.-lb.)	13 N•m (115 in.-lb.)	17 N•m (150 in.-lb.)	6.3 N•m (56 in.-lb.)
M8	14 N•m (124 in.-lb.)	18 N•m (159 in.-lb.)	22 N•m (195 in.-lb.)	28 N•m (248 in.-lb.)	31 N•m (274 in.-lb.)	40 N•m (354 in.-lb.)	15 N•m (133 in.-lb.)
M10	28 N•m (21 ft.-lb.)	36 N•m (27 ft.-lb.)	43 N•m (32 ft.-lb.)	56 N•m (41 ft.-lb.)	61 N•m (45 ft.-lb.)	79 N•m (58 ft.-lb.)	30 N•m (22 ft.-lb.)
M12	49 N•m (36 ft.-lb.)	63 N•m (46 ft.-lb.)	75 N•m (55 ft.-lb.)	97 N•m (72 ft.-lb.)	107 N•m (79 ft.-lb.)	138 N•m (102 ft.-lb.)	53 N•m (39 ft.-lb.)
M16	121 N•m (89 ft.-lb.)	158 N•m (117 ft.-lb.)	186 N•m (137 ft.-lb.)	240 N•m (177 ft.-lb.)	266 N•m (196 ft.-lb.)	344 N•m (254 ft.-lb.)	131 N•m (97 ft.-lb.)
M20	237 N•m (175 ft.-lb.)	307 N•m (226 ft.-lb.)	375 N•m (277 ft.-lb.)	485 N•m (358 ft.-lb.)	519 N•m (383 ft.-lb.)	671 N•m (495 ft.-lb.)	265 N•m (195 ft.-lb.)
M24	411 N•m (303 ft.-lb.)	531 N•m (392 ft.-lb.)	648 N•m (478 ft.-lb.)	839 N•m (619 ft.-lb.)	897 N•m (662 ft.-lb.)	1160 N•m (855 ft.-lb.)	458 N•m (338 ft.-lb.)

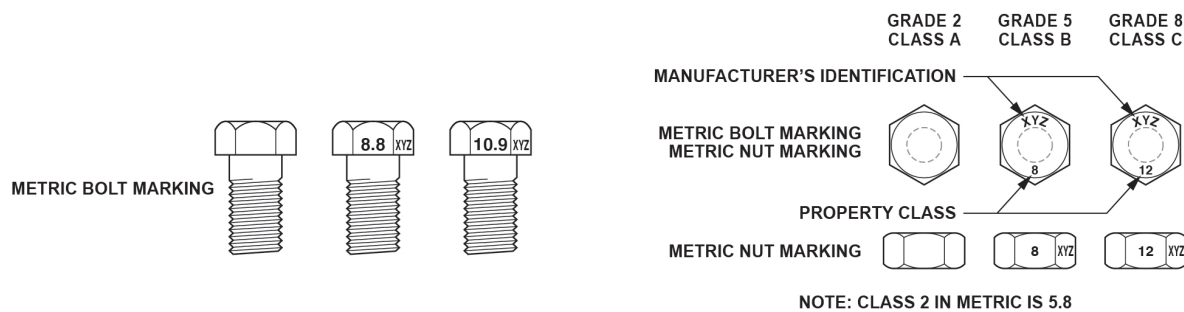



www.loftness.com

Loftness Specialized Equipment, Inc.
650 So. Main Street • PO Box 337 • Hector, MN 55342
Tel: 320.848.6266 • Fax: 320.848.6269 • Toll Free: 1.800.828.7624

Printed in USA
© Loftness 2026