



Kwik Trim 53

**Owner's Manual and Parts Book
(Originating with Serial Number 64-171)**



Model Number: _____
Serial Number: _____
Date of Purchase: _____



LOFTNESS SPECIALIZED EQUIPMENT, INC.

LIMITED WARRANTY POLICY

The limited warranty policy begins upon delivery of the unit to the original customers.

All Loftness products have a one (1) year limited warranty. The XLB10 Grain Bag Loader has a two (2) year limited warranty.

If any Loftness product is used as rental equipment the limited warranty period is for only 30 days from the delivery date to the original customers.

Loftness Specialized Equipment, hereinafter referred to as LOFTNESS, a manufacturer of quality machinery since 1956, warrants new LOFTNESS machinery and/or attachments at the time of delivery to the original purchaser, to be free from defects in material and workmanship when properly set up and operated in accordance with the recommendations set forth in the LOFTNESS Operator's Manual.

LOFTNESS' liability for any defect with respect to accepted goods shall be limited to repairing the goods at an authorized dealer or other LOFTNESS designated location, or replacing them as LOFTNESS shall elect. The above shall be in accordance with LOFTNESS warranty adjustment policies.

WARRANTY REQUIREMENTS

Warranty registration form must be filled out and returned to Loftness Specialized Equipment to validate all warranty claims.

To receive a warranty claim, a return authorization from LOFTNESS must be obtained. The failed part may then be returned in an untampered status. This warranty does not include freight or delivery charges incurred when returning machinery for servicing. Dealer mileage, service calls and pick-up/delivery charges are the customer's responsibility.

LIMITATIONS OF WARRANTY

LOFTNESS products are designed to provide years of dependable service when proper use and maintenance is adhered to. The potential for misuse in many applications exists; therefore, a limited warranty is provided as follows.

This warranty shall not apply to any machine or attachment which shall have been repaired or altered outside the LOFTNESS factory or authorized LOFTNESS dealership or in any way so as in LOFTNESS' judgment, to affect its stability or reliability, nor which has been subject to misuse, negligence or accident, nor to any machine or attachment which shall not have been operated in accordance with LOFTNESS' printed instructions or beyond the company recommended machine rated capacity. LOFTNESS may elect to have an area representative evaluate the condition of the machine before warranty is considered.

In addition, this limited warranty provides no coverage for general wear or maintenance items, misuse, environmental conditions and/or contamination for which they were not designed or not intended, including but not limited to the following items:

- Use of machine beyond its rated capacity;
- Improper knife replacement;
- Missing knives;
- Striking foreign objects
- Lack of lubrication
- Failures caused by running in an "out-of-balance" condition;
- Tires;
- Conveyors;
- Auger wear;
- Saw blades; and
- Brakes and brake pads.

EXCLUSIONS OF WARRANTY

Except as otherwise expressly stated herein, LOFTNESS makes no representation or warranty of any kind, expressed or implied. **The implied warranty of merchantability and fitness for a particular purpose are excluded from this limited warranty.** The remedies set forth in this warranty are the only remedies available to any person under this warranty. LOFTNESS shall have no liability to any person for incidental, consequential or special damages of any description, whether arising out of express or implied warranty or any other contract, negligence, or other tort or otherwise. This exclusion of consequential, incidental and special damages is independent from and shall survive any finding that the exclusive remedy failed of its essential purpose. Upon purchase, the buyer assumes all liability, all personal injury and property damage resulting from the handling, possession or use of the goods by the buyer.

No agent, employee or representative of LOFTNESS has any authority to bind LOFTNESS to any affirmation, representation or warranty concerning its machinery and/or attachments except as specifically set forth herein.

July 2019

Delivery Report and Warranty Registration Form

Dealer Information

Dealer Name _____

Address _____

City, State/Province, Zip _____

Purchaser Information

Name _____

Address _____

City _____

State/Province _____

Zip _____

County _____

Phone Number _____

Occupation _____

Email Address _____

Machine Information

Model Number _____

Serial Number _____

Engine Serial Number _____

Hour Meter Reading _____ Date Delivered _____

WARNING

Kwik-Trim must be used only as recommended by the manufacturer and with complete parts such as: guards, manuals, seat belts, and signs. Misuse or modification of Kwik-Trim may cause injury or death.

The following items are to be checked as they are explained to the owner / operator by the seller at the time of delivery.

1. Make sure the customer receives a copy of the operator's manual. Explain that it is the operator's responsibility to read and understand this manual.
2. Review machine safety signs (Decals) and operator's manual instructions.
3. Advise owner that dealer is the source for operator training by providing demonstrations, publications, and review of job requirements.
4. Explain capabilities and restrictions of the Kwik - Trim for job usage as indentified by owner / operator.
5. Show how to enter and exit the machine safely, demonstrate use and functions of Safety Lock Lever.
6. Explain the rated operating capacity for safety and stability of the Kwik - Trim.
7. Advise of maximum gradability and maximum lateral tipping angle as outlined in operator's manual.
8. Explain use of operator cab or canopy, seat belt, and security of front window, if equipped. Do not weld, drill, modify, or remove the cab or canopy structure.
9. Demonstrate use and functions of all electric and hydraulic controls.
10. Demonstrate use and function of slew locks on all applicable machines.
11. Demonstrate how to start, stop, turn, and park the Kwik - Trim. Explain the effect of the machine orientation in regards to the travel controls and direction. Also show how to attach, disconnect, fill, carry, and dump the bucket or other approved attachments.
12. Review maintenance, cleaning, and safety procedures as found in operator's manual with operator and / or maintenance personnel, note pressurized hydraulic reservoir.
13. Explain recommended fueling and lubricating procedures.
14. Explain proper procedure and importance of track adjustment as stated in operator's manual and review operating conditions that limit or reduce track life.
15. Explain that pulling, dragging, towing, or winching the machine may damage the equipment.
16. Explain and deliver warranty policy and limitations to owner / operator. A copy of the Takeuchi New Machine Limited Warranty appears on page two of this delivery report.

The above delivery information has been explained to me. I fully understand the operation and maintenance of this machine. I also acknowledge the warranty conditions and limitations as outlined in my copy of the New Machine Limited Warranty Statement.

Owner / Operator Signature _____

Date _____

Seller's Representative Signature _____

Date _____

Note: Takeuchi must receive an original delivery receipt with the customer's original signature. Photocopies or faxes are not sufficient for registration purposes.

Takeuchi Mfg. (U.S.), Ltd. provides the following "New Machine Limited Warranty" to the first purchaser of each new Takeuchi machine.

1) WARRANTY PERIOD:

Subject to the terms of this warranty, Takeuchi warrants to the first purchaser that the new Takeuchi machine will be free from defects in material and workmanship for the warranty period set forth below. The warranty period starts at the time the machine is first placed into service by anyone.

- New Machines – 24 months or 2,000 hours of use whichever occurs first
- Takeuchi Replacement Parts – 12 months or to the end of the new machine warranty period, whichever is longer
- Batteries – 12 months, Pro Rata Basis
- Takeuchi Field Installed Attachments – 90 Days
- Rubber Tracks – Takeuchi brand OEM 12 months, Pro Rata Basis; NON-OEM 12 months or 500 hours whichever occurs first, Pro Rata Basis
- Rubber Tires – Contact tire manufacturer for warranty information and consideration.

2) THE TAKEUCHI NEW MACHINE LIMITED WARRANTY DOES NOT COVER:

- Any machine which has been altered or modified in a manner which, in the sole judgment of Takeuchi, affects its performance, stability, or reliability, including the use of non-approved attachments.
- Depreciation or damage caused by normal wear and tear, by failure to properly maintain the machine, improper use or abuse of the machine, collision, fire, or other accident, vandalism, negligence, other casualty or operation beyond rated capacity or specifications.
- Parts or components that are covered by separate and specific warranties, including but not limited to Engine Emission Control systems, tires, and warranties extended by other manufacturers.
- Accident or damage caused by the environment, such as but not limited to, exposure to corrosive or hazardous materials.
- Replacement of wear items, such as but not limited to: buckets, bucket teeth, cutting edges, ground engaging tools, pins, bushings, paint, glass, radios, wheels, and abuse, neglect, or wear of tires, tracks, and undercarriage components.
- Normal maintenance parts and labor, including but not limited to: replenishment of oils, lubricants, coolants, fluids, hydraulic oil, lights, filters, belts, hoses, and fittings.
- Machines not properly registered with Takeuchi when first placed in service.
- Costs associated with pickup and delivery of the equipment, rental of replacement equipment during the repair period, economic loss during the repair, overtime labor charges, travel time, mileage or zone charges, and freight charges of replacement parts.

3) SECURING WARRANTY SERVICE

- Takeuchi will, during the applicable warranty period, repair or replace, at its option any component or parts (except those specified above) that, as delivered to the original purchaser, are defective in material and workmanship. Takeuchi will determine in its sole discretion, whether a defect or failure is covered by this warranty. No charge shall be made to the purchaser for parts and reasonable labor incurred in making the repairs except as otherwise stated below.
- Warranty repairs will be performed by an authorized Takeuchi service center upon delivery of the machine or defective part to the service center. At the time of requesting the warranty service, the purchaser must present evidence of the date of purchase of the machine.
- The purchaser shall pay any premium for overtime and additional labor requested by the purchaser, any charge for field service calls, mileage charges, transporting the machine or parts thereof to and from the place where the warranty repair is performed and any unusual freight charges for the shipment of parts from Takeuchi which the purchaser may request.

4) NO REPRESENTATIONS OR IMPLIED WARRANTIES:

THIS LIMITED WARRANTY IS THE ONLY WARRANTY MADE BY TAKEUCHI MFG. (U.S.), LTD., A GEORGIA CORPORATION, AND ITS AFFILIATES AND NEITHER TAKEUCHI NOR ANY COMPANY AFFILIATED WITH TAKEUCHI MAKES ANY OTHER WARRANTIES, REPRESENTATIONS, OR PROMISES, EXPRESS OR IMPLIED, AS TO THE QUALITY, PERFORMANCE, SERVICE, REPAIR, TRANSPORT, OR OTHER USE OF TAKEUCHI MACHINES OR COMPONENTS THEREOF. **TAKEUCHI EXPRESSLY EXCLUDES AND DISCLAIMS ANY AND ALL IMPLIED WARRANTIES, INCLUDING THE IMPLIED WARRANTIES OF FITNESS FOR A PARTICULAR PURPOSE AND MERCHANTABILITY.**

NO PERSON IS AUTHORIZED TO MAKE ANY REPRESENTATIONS, WARRANTIES, OR PROMISES ON BEHALF OF TAKEUCHI OR ITS AFFILIATES, OR TO MODIFY THE TERMS OR LIMITATIONS OF THIS WARRANTY. THIS WARRANTY IS PROVIDED EXCLUSIVELY TO THE FIRST PURCHASER OF QUALIFYING TAKEUCHI MACHINES AND MAY NOT BE ASSIGNED OR OTHERWISE TRANSFERRED.

5) REMEDIES EXCLUSIVE:

THE SOLE AND EXCLUSIVE REMEDY OF ANY PERSON, AND THE SOLE AND EXCLUSIVE OBLIGATION AND LIABILITY OF TAKEUCHI AND ITS AFFILIATES, WITH RESPECT TO ANY TAKEUCHI MACHINE OR COMPONENTS IS THE LIMITED WARRANTY SET FORTH HEREIN. TAKEUCHI WILL IN NO EVENT BE LIABLE FOR ANY DIRECT, INDIRECT, SPECIAL, PUNITIVE, INCIDENTAL, OR CONSEQUENTIAL DAMAGES OR INJURIES CAUSED BY ANY MACHINE OR ITS COMPONENTS, WHETHER ARISING IN CONTRACT OR IN TORT, INCLUDING BUT NOT LIMITED, TO LOSS OF PROFIT, BUSINESS INTERRUPTION, COST OF RENTAL, OR SUBSTITUTE EQUIPMENT, OR ANY OTHER COMMERCIAL LOSS OR FOR DAMAGES OF ANY KIND WHETHER OR NOT TAKEUCHI AND ITS AFFILIATES HAVE BEEN ADVISED OF OR COULD HAVE FORESEEN THE POSSIBILITY OF SUCH DAMAGES. IN NO EVENT WILL TAKEUCHI'S LIABILITY TO ANY PERSON REGARDLESS OF THE FORM OF ACTION EXCEED THE PURCHASE PRICE OF THE MACHINE.

LOFTNESS ™

Table of Contents

Warranty

Table of Contents

Introduction

Owner Information	1
Warranty Policy	1
Serial Number Location	1
Loftness Serial Number	1
Takeuchi Serial Number	1
Manual Storage	2
Fire Extinguisher Storage.	2
Machine Overview	2
Design Limitations	2
Off-Road Operation	2
Operating And Safety Precautions.	2
Operating Position	3
Transport Position	3
Kwik Trim Features	3
Operating Ranges	4
94 Degree Arc	4
70 Degree Tilt.	4
360 Degree Continuous Swing	4
Extend	4
Kwik Trim Identification	5

Safety Instructions

Safety First.	7
Owner's Responsibility	7
Safety Rules.	8
Operating Safety	8
Hydraulic Safety.	8
California Proposition 65 Warning	9
Emergency Evacuation - Safety Windows.	9
Safety Decal Locations	9

Operating Instructions

Entering The Machine	13
Exiting The Machine	13
Hydraulic Controls	14
Extending And Retracting the Boom from and to Transport Position	14
Raising And Lowering the Boom	15
Extending and Retracting the Saw Blade	15
Tilting the Mast.	16
Saw Blade	16
Dozer Blade	17

Table of Contents

Operating Instructions (Cont'd)

Winch	17
Blade Angle Adjustment	18
Operation	18
Operating The Kwik Trim	18
Operating The Kwik Trim on a Slope	20
Switching to Transport Position	20
Transport Position	20
Lower and Retract Boom	20
Service Steps	21
Climbing Service Steps	21
Loading And Unloading	21
Loading	21

General Maintenance

General Maintenance	23
Fluids And Lubricants	23
Lubrication	24
Grease Points	24
Releasing Hydraulic Pressure	25
Saw Blade	26
Blade Inspection	26
Blade Removal	26
Blade Installation	26
Boom	27
Care And Maintenance	27
Electrical Conductivity Test	27
Boom Inspection And Repairs	27
Installing New Hose Reel Hoses	28
Troubleshooting	29

Parts Identification and Hydraulic Schematics

Kwik Trim Assembly	32
Mast, Boom Mount	34
Boom Assembly (N38189)	36
Boom Assembly (N38189)	37
Boom Assembly (N38189) (Cont'd)	38
Boom Assembly (N38189) (Cont'd)	38
Boom Assembly (N38189) (Cont'd)	40
Jig, Motor Mount (N31760)	41
Outer Tube Assembly (N38192)	42
Tube, w/Slides Inner (N24496)	44
Clamp, Cradle Top w/Slides (N38185)	45
Cradle Assembly (N38178)	46

Table of Contents

Parts Identification and Hydraulic Schematics (Cont'd)

Motor Assembly (N24594)	47
Motor (N38121)	48
Hydraulic Hose Reel (N38309).	49
Hydraulics	50
Hydraulics (Cont'd)	52
Hydraulics (Cont'd)	54
Hydraulics (Cont'd)	56
Hydraulics (Cont'd)	58
Hydraulics, Winch	60
Hydraulic Schematic - Lift, Tilt, Transport Cylinders	62
Hydraulic Schematic - Boom and Saw	63
Hydraulic Schematic, Winch	64
Windows; Front, Top and Left Side	66
Windows; Rear and Right Side	68
Window, Escape (N105428).	69
Top Cover Assembly (N129683)	70
Blade and Track Cover	72
Cover Plate	73
Fire Extinguisher	74
Machine Decals and Signs	75
Takeuchi TB260 Filters.	78

Appendix

Specifications	79
Dimensions	80
Torque Specifications	81
Inches Hardware and Lock Nuts	81
Metric Hardware and Lock Nuts	82



Owner Information

Thank you for your decision to purchase a Kwik Trim 53 from Loftness. To ensure maximum performance of your machine, it is mandatory that you thoroughly study the owner's manual and follow its recommendations. Proper operation and maintenance are essential to prevent injury or damage and to maximize machine life.

It is also important to read and understand the Takeuchi TB260 Operator's Manual and follow its instructions and recommendations.

Operate and maintain this machine in a safe manner and in accordance with all applicable local, state, and federal codes, regulations and/or laws, and in compliance with on-product labeling and these instructions.

Make sure that all personnel have read this owner's manual and thoroughly understand safe and correct operating, installation and maintenance procedures.

Continuous improvement and advancement of Loftness products may result in changes to your equipment that may not be reflected in this publication. Loftness reserves the right to make product improvements to the machine at any time. Although great care has been taken to ensure the accuracy of this publication, Loftness does not assume any liability for errors or omissions.

Warranty Policy

Be sure to read and understand the Warranty Policy at the beginning of this manual. It is also important that you fill out the Warranty Registration form(s) completely and return to Loftness so as not to void the warranty.

Serial Number Location

Loftness Serial Number

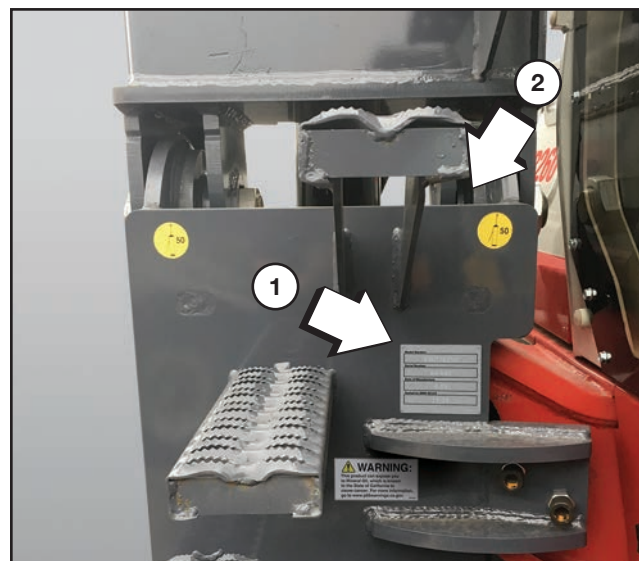

The arrows indicate the location of the Loftness serial number tag (1), and the location of the serial number stamped into the frame (2).

Always use your model and serial number when requesting information or when ordering parts.

Takeuchi Serial Number

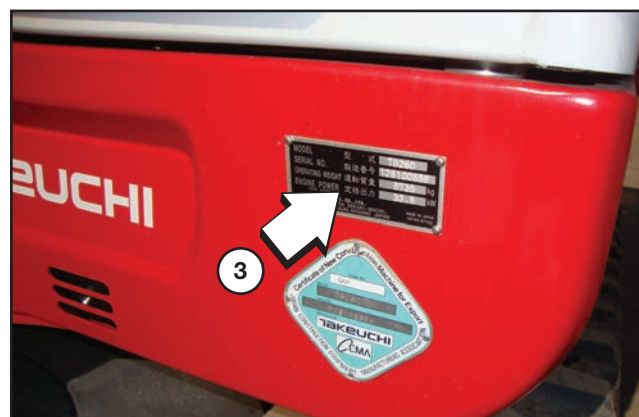

The arrow above indicates the location of the Takeuchi excavator serial number tag (3).

Introduction

Manual Storage

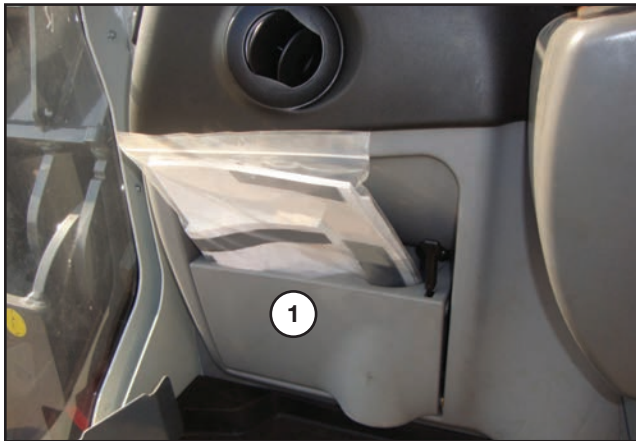

Keep the owner's manual and the entire documentation packet in the storage compartment (1) located inside the cab. The owner's manual must be available for all operators.

Fire Extinguisher Storage



The fire extinguisher is located in the back left hand corner of the operator cab.

Machine Overview

Design Limitations

This machine is designed as an off-road all-terrain vehicle. The fundamental design concept is a compromise between ruggedness which calls for strength and weight versus light-footedness to move over swampy wet areas. Although the machine is exceptionally rugged for its class, it is still a light machine and its operation must be restricted to its proper purpose. The addition of weight to any part of the machine changes its stability and modifies its performance.

Off-Road Operation

NOTE: *Off-road operation is dangerous. Never assume that one off-road machine has the same operating capabilities as another. There are many varieties of different sizes and designs of off-road machines. Each is built with differing operating abilities.*

Off-road terrain which has not been specially prepared to carry machines presents an inherent danger where angularity, dirt substance, and exact steepness are unpredictable. The terrain presents a continual element of danger which must be knowingly accepted by anyone venturing over it.

When operating the machine off-road, the operator must always use extreme care in selecting the safest path and keeping a close watch on terrain ahead. The machine should NEVER be operated by anyone who is not familiar with the operating instructions applicable to the machine nor should the machine be operated in steep or treacherous terrain by anyone not thoroughly familiar with the machine's performance on moderate terrain.

Operating And Safety Precautions

Care, caution, experience and driving skill are the best precautions against the hazards of off-road machine operation. Whenever there is the slightest doubt that the machine can safely negotiate an obstacle on a particular piece of terrain, always choose an alternate route. In offroad operation, power and traction, not speed, are important. Never drive faster than visibility, terrain and your own ability to select a safe route permits. Constantly watch the terrain ahead for sudden changes in slopes or obstacles such as rocks, logs, or stumps that may cause loss of stability, resulting in tip-over or roll-over.

Operating Position

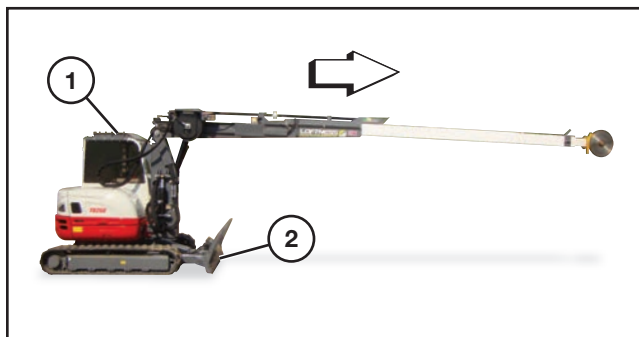

The operating position is when the boom/saw blade are extended forward until the rear of the boom clears the operator's cab (1) and the dozer blade (2) lowered to the ground.

Transport Position

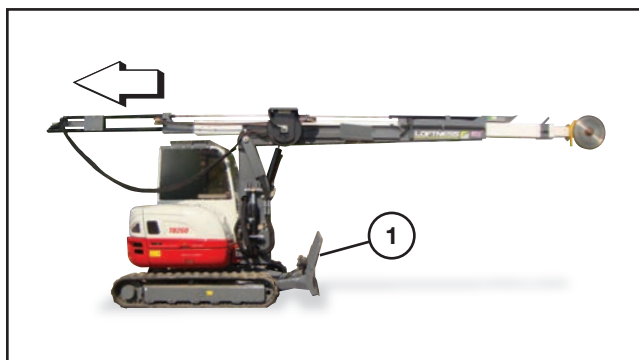

The transport position is when the boom/saw blade are parallel with the ground, the boom fully retracted and the dozer blade (1) in the raised position.

Kwik Trim Features

Cab

- Climate-controlled cab.
- Custom full-view tinted polycarbonate skylight and windshield with custom protective guarding.
- Fully adjustable seat.
- Standard with AM/FM radio (MP3 jack).
- Cup holder.

Engine

- The quiet, efficient 47.6 HP diesel engine uses less than 1.6 gal. (6.05 l) of fuel per hour.

Hydraulics

- Pilot-operated joysticks for low effort, precise control.
- Pattern control selector valve to choose (ISO) pattern.
- Variable displacement piston pumps.
- Large capacity oil cooler.
- Custom valving for precise trimmer operation.

Boom

- 53 ft. fiberglass, non-conductive boom.
- The Kwik Trim has been dielectrically certified to ANSI A92-2 Category C Standards to 100KV for operator safety.
- The telescopic function is driven by a simple, longstroke hydraulic cylinder for lower maintenance than chain + sprocket systems.
- Innovative, single reel design provides reliable, rugged service.
- The unique reel-mounting configuration provides a clean, straight pull on the hoses throughout the full range of boom motion.
- No corners or idlers to go around.

Cutting Blade

- The Kwik Trim uses the industry standard 24 in. (609.6 mm) carbide-tipped saw blade operating at 3000 RPM.
- Uses only high quality, industry proven drive components.

Certifications

- Boom – ANSI A92-2 Category C
- ROPS - ISO3471, ISO12117-2, 8082-2
- OPS - ISO8084
- FOPS - ISO8083

Weight

- 14,000 lb. (6,350 kg)

Introduction

Operating Ranges

94 Degree Arc



The rigid, rectangle telescopic boom provides superior saw placement compared to more flexible round booms. Solid precise saw placement when fully extended is assured through use of the latest in hydraulic control technology.

See “Raising And Lowering the Boom” on page 15.

70 Degree Tilt

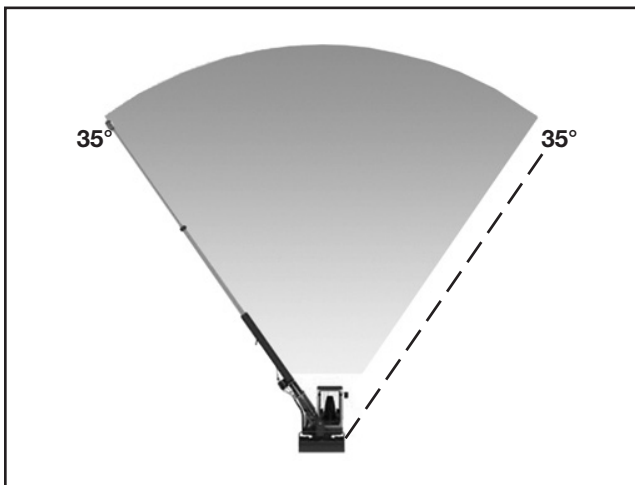

Additional “Boom Tilt Articulation” gives the operator more saw blade positioning options making the most difficult cut possible. 35° left or right operating range.

See “Tilting the Mast” on page 16.

360 Degree Continuous Swing

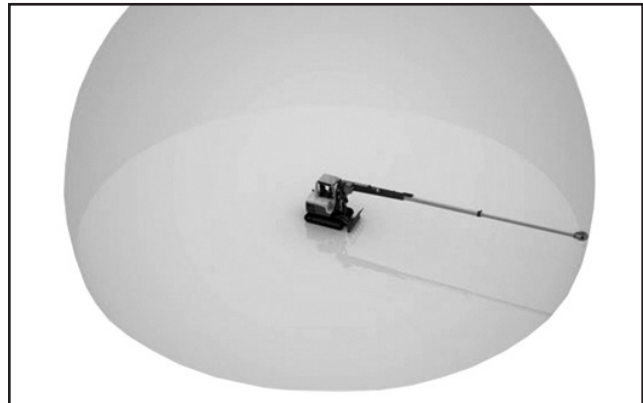

Providing the ultimate in agility and stability, the Kwik Trim platform delivers extraordinary maneuverability allowing operators to safely approach and position the Kwik Trim securely within tight job site environments and difficult terrain.

See the machine’s “Owner’s Manual” for detailed information for operating the machine.

Extend

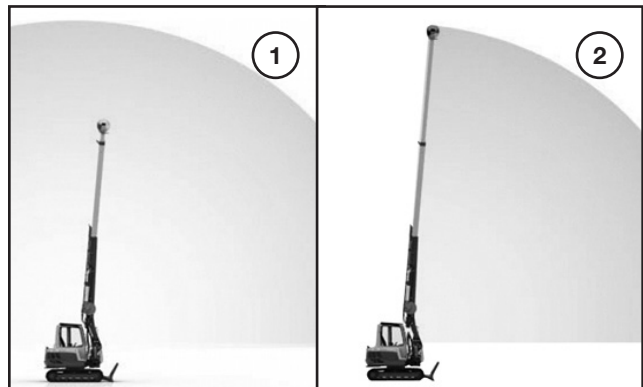

39 ft. reach when the inner boom is fully retracted (1) and a 53 ft. reach fully extended (2).

The telescopic function is driven by a simple, long-stroke hydraulic cylinder for lower maintenance than chain and sprocket systems. See “Extending and Retracting the Saw Blade” on page 15 for operation instructions.

Kwik Trim Identification

Kwik Trim shown in transport mode.

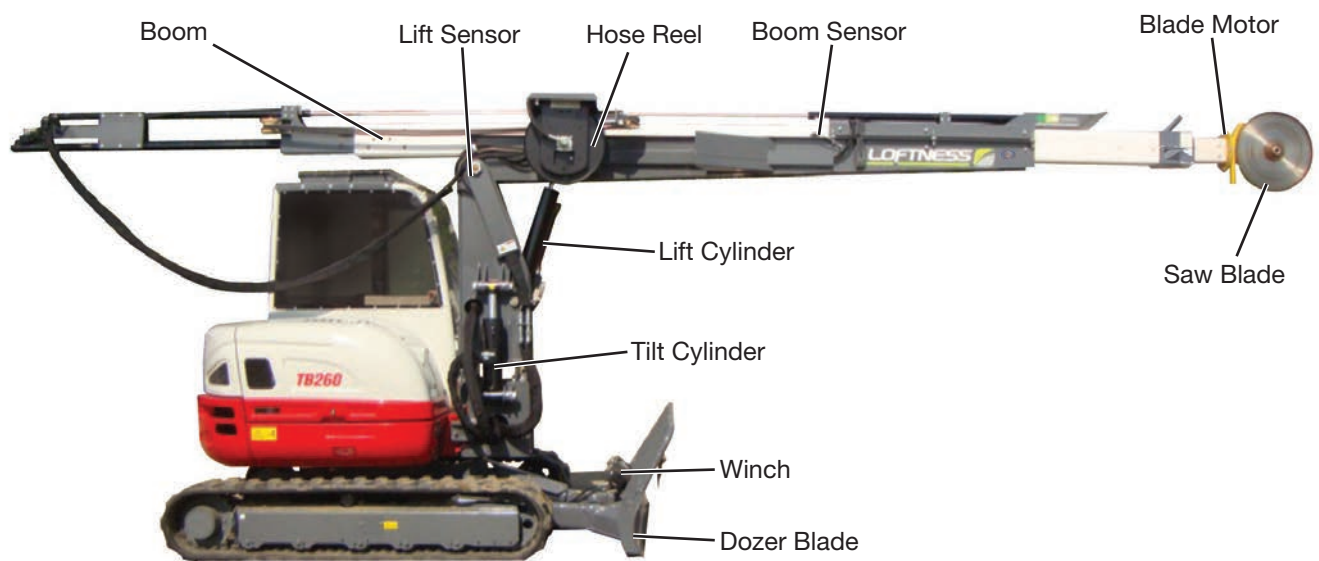



Safety First

Accidents can be prevented by recognizing the causes or hazards before an accident occurs and doing something about them. Regardless of the care used in the design and construction of this machine, there are some areas that cannot be safeguarded without interfering with accessibility and efficient operation.



Safety Alert Symbol

This message alert symbol identifies important safety messages on the machine and in the owner's manual. When you see this symbol, be alert to the possibility of personal injury and carefully read the message that follows.

In the owner's manual and on decals used on the machine the words **DANGER, WARNING, CAUTION, IMPORTANT, and NOTE** are used to indicate the following:

DANGER: This word warns of immediate hazards which, if not avoided, will result in severe personal injury or death. The color associated with Danger is RED.



WARNING: This word refers to a potentially hazardous situation which, if not avoided, could result in severe personal injury or death. The color associated with Warning is ORANGE.

CAUTION: This word refers to a potentially hazardous or unsafe situation that, if not avoided, may result in minor or moderate injury. It may also be used to alert against unsafe practices. The color associated with Caution is YELLOW.

IMPORTANT: Highlights information that must be heeded.

NOTE: A reminder of other related information that needs to be considered.

If Safety Decals on this machine are ISO two panel pictorial, decals are defined as follows:

- The first panel indicates the nature of the hazard.
- The second panel indicates the appropriate avoidance of the hazard.
- Background color is YELLOW.
- Prohibition symbols such as  and  if used, are RED.

Be certain all machine operators are aware of the dangers indicated by safety decals applied to the machine, and be certain they follow all safety decal instructions. Contact Loftness for safety decal replacement.

Loftness cannot anticipate every possible circumstance that may involve a potential hazard. The warnings in this owner's manual are not all inclusive.

Owner's Responsibility

Operate and maintain this machine in a safe manner and in accordance with all applicable local, state, and federal codes, regulations and/or laws and in compliance with on-product labeling and this owner's manual instructions.

Make sure that all personnel have read this owner's manual, and thoroughly understand safe and correct installation, operation and maintenance procedures.

At regular intervals thereafter, the machine should be serviced in accordance with procedures outlined in this owner's manual.

Fulfill all warranty obligations so as not to void the warranties. The warranty policy included in this manual outlines the warranty policy of Loftness.

Safety Instructions

Safety Rules

These are general safety considerations. Additional precautions may be necessary to operate your machine in a safe manner. Be certain you are operating your machine in accordance with all safety codes, OSHA rules and regulations, insurance requirements and local, state, and federal laws.

Operating Safety

- Do not allow anyone to operate the machine until he or she has read the owner's manual and is completely familiar with all safety precautions.
 - Do not allow inexperienced persons unfamiliar with the machine, or unfamiliar with safe operating and maintenance procedures, to operate or maintain the machine.
 - Do not allow persons under the influence of alcohol, medications, or other drugs that can impair judgment or cause drowsiness to operate or maintain the machine.
 - Keep children, bystanders and other workers away from the machine while it is operating. No riders allowed.
 - The machine requires an operator at all times. Never leave the machine running and unattended.
 - Do not wear loose hanging clothes, neckties or jewelry. Long hair is to be placed under a cap or hat. These precautions will help prevent you from becoming caught in any moving parts on the machine.
 - Do wear safety glasses, ear protection, respirators, gloves, hard hats, safety shoes and other protective clothing when required.
 - Make sure the operator's area is clear of any distracting objects. Keep work areas clean and free of grease and oil to avoid slipping or falling.
 - Periodically check all guards, shields and structural members. Replace or repair anything that could cause a potential hazard.
 - Do not replace components or parts with other than factory-recommended service parts. To do so may decrease the effectiveness of the machine.
 - It is the operator's responsibility to be aware of machine operation and work area hazards at all times.
- Operators are responsible to be aware of safety hazard areas and follow instructions on warning, caution, or danger decals applied to the machine.
 - Know the area before operating the machine. Be aware of power lines, buildings or other equipment. Watch for adequate overhead clearance.
 - Do not lubricate parts while the machine is running.
 - Do not smoke while servicing the machine.
 - Be sure the machine is in the transport position before transporting.
 - Always have an operator in the operator's seat while the machine is in operation.
 - Never attempt to make any adjustments while the excavator engine is running or the key is in the "ON" position in the excavator. Before leaving the operator's position, disengage power to the machine and remove ignition key.
 - If you must operate the Kwik Trim while traveling, operate at speeds slow enough so you have complete control at all times.
 - On uneven ground, maintain the low speed and avoid starting, stopping or changing directions abruptly.
 - Do not leave equipment in the raised position.
 - Avoid crossing over obstacles whenever possible. If you must do so, keep the Kwik Trim boom in the transport position and travel slowly.
 - Always cut in an up and down direction on slopes. To avoid loss of control and to prevent overturn, never cut across the slope.

Hydraulic Safety

- The hydraulic system is under high pressure. Make sure all lines and fittings are tight and in good condition. These fluids escaping under high pressure can have sufficient force to penetrate skin and cause serious injury.
- Never check for leaks by using any part of your body to feel for escaping fluid.



WARNING: Contact with high pressure fluids may cause fluid penetration and burn hazards. Fluid that is under pressure can penetrate body tissue. Fluid penetration can cause serious injury and possible death. If fluid is injected into the skin, seek medical attention immediately!

Safety Instructions

California Proposition 65 Warning

	WARNING: <i>This product can expose you to Mineral Oil, which is known to the State of California to cause cancer. For more information, go to www.p65warnings.ca.gov.</i>
---	---

A decal with this warning statement is adhered to the machine. If the decal should become worn or missing, replace immediately.

Emergency Evacuation - Safety Windows

In case of an emergency, the rear window on the excavator can be removed when access via the side door has been denied and the operator must make an immediate exit.

If the operator is unable to remove the window from the inside, and side door access has been denied, someone from outside the unit can remove the window from the exterior of the excavator as well.

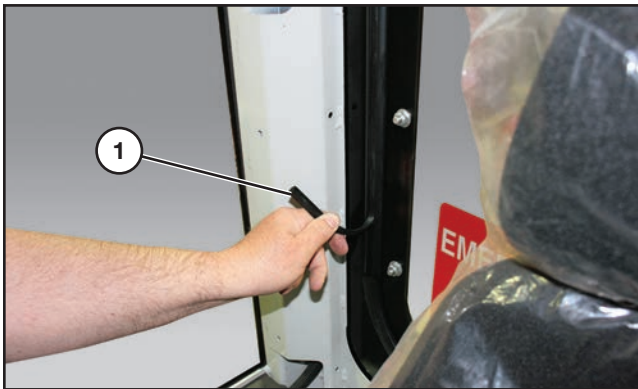

To remove the window from the inside, locate and grab end of the rubber locking strip (1) and pull out.

Push the window out forcefully, being aware of the outside surroundings.

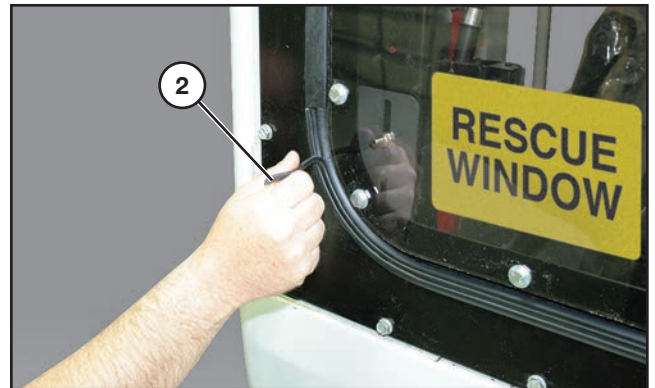

To remove the window from the outside, locate and grab the end of the rubber locking strip (2) and pull out.

Grab and lift the window out of the frame.

	WARNING: <i>Do not try to push the window in.</i>
---	--

Safety Decal Locations

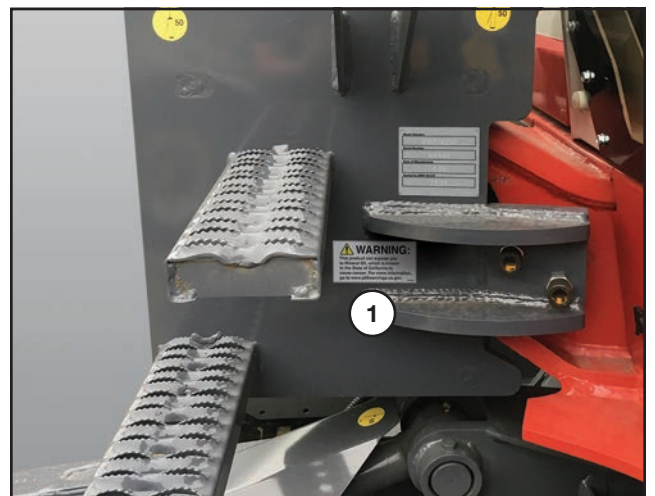

1	 WARNING: This product can expose you to Mineral Oil, which is known to the State of California to cause cancer. For more information, go to www.p65warnings.ca.gov . <small>203264</small>
----------	--

Part No. 203264

Safety Instructions

Safety Decal Locations (Cont'd)

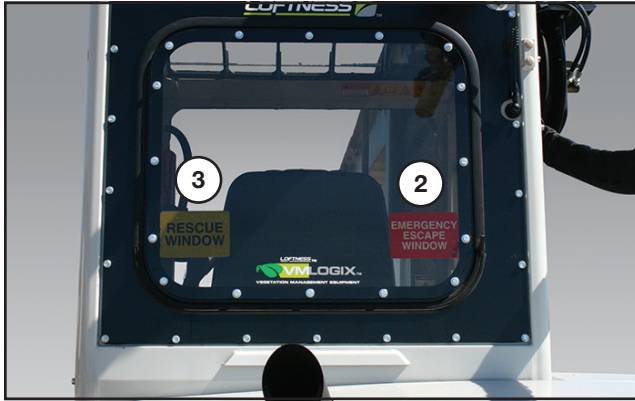

NOTE: The back sides of the yellow “RESCUE WINDOW” and red “EMERGENCY ESCAPE WINDOW” decals shown are right-reading to the operator from inside of the cab.



Part No. N34420



Part No. N34419



Part No. N23506

Safety Decal Locations (Cont'd)

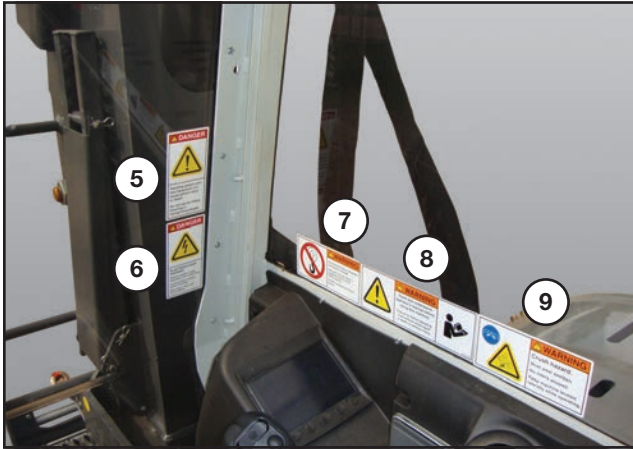

5



Part No. N28464

6



Part No. N28461

7

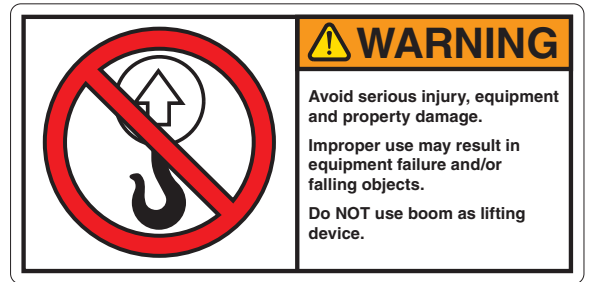

Part No. N24863

8

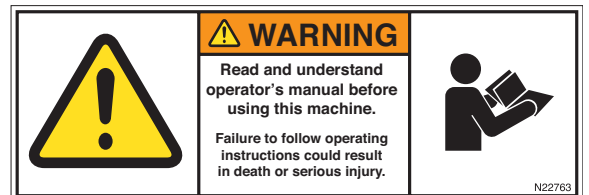

Part No. N22763

9

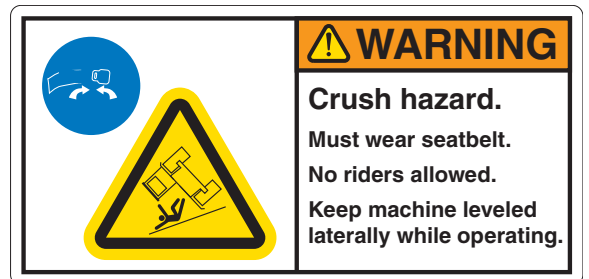

Part No. N28462



Operating Instructions

Entering The Machine



WARNING: Before operating the machine:

- Keep seatbelt fastened.
- Keep left console lowered.
- Keep arms and feet in cab.



Use the handles and tracks to enter and exit the machine.

NOTE: Never use the safety lock lever or control levers as hand holds.

NOTE: Maintain three-point contact at all times while entering or exiting the excavator. Do not jump.

Adjust the seat belt so the belt is over the operator's hips. Fasten the seat belt snugly.



Lower the left control lever (1) console.

Close cab door.

Start the engine.

Exiting The Machine

Park the machine on a flat, rigid and safe ground. Set the parking brake.

Lower the dozer blade to the ground.



Stop the engine, unfasten seat belt and remove the key. Lift up on the lever (1) to release and raise the control console.

Exit the excavator.

Lock the cab and covers and take the key with you.

Operating Instructions

Hydraulic Controls

NOTE: This section refers to the front, rear, left and right of the machine as seen when sitting in the operator's seat with the dozer blade visible to the front.

Extending And Retracting the Boom from and to Transport Position

Before any boom operations such as raising, lowering, and tilting can be performed, the boom must be extended from its transport position. And before transporting, the boom must be returned to its transport position.

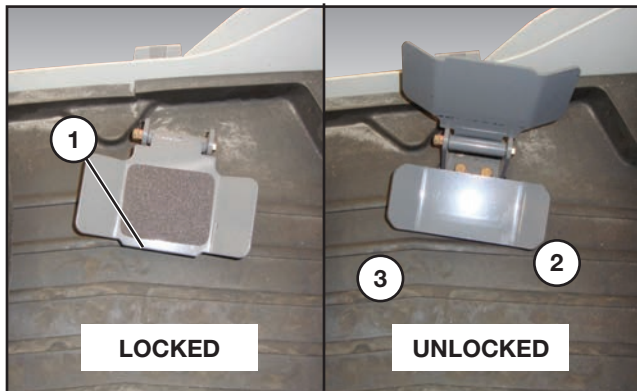

Raise the top (1) of the right foot pedal to unlock the pedal.

Extending Boom into Operating Position

Press the right side (2) of the foot pedal to extend the boom to operating position.

The engine RPM must be raised above idle to extend the boom.

NOTE: An extend/retract sensor locks and unlocks the boom raise/lower functions on the foot control.

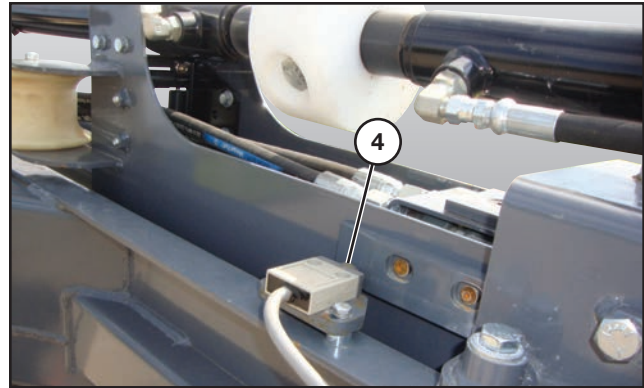

When the boom assembly is extended into operating position, the sensor (4) will activate and enable the raise/lower functions.

Retracting Boom to Transport Position

Press the left side (3) of the foot pedal to retract the boom assembly back into transport position.

The engine RPM must be raised above idle to extend the boom.

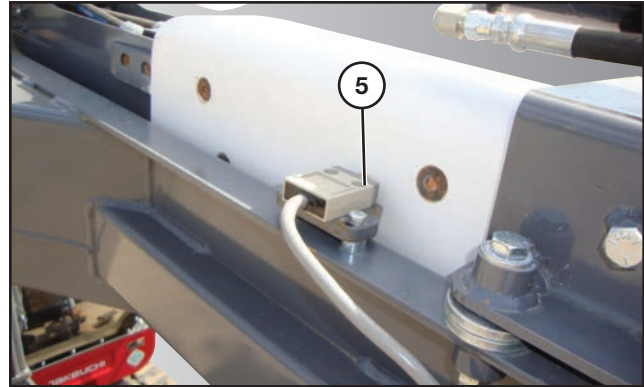

NOTE: The boom must be raised or lowered until parallel with the ground before retracting the boom assembly.

Retract the boom assembly until the boom stops.

NOTE: Once the sensor contacts the top of the boom, raise/lower functions are deactivated.

Operating Instructions

Retracting Boom to Transport Position (Cont'd)

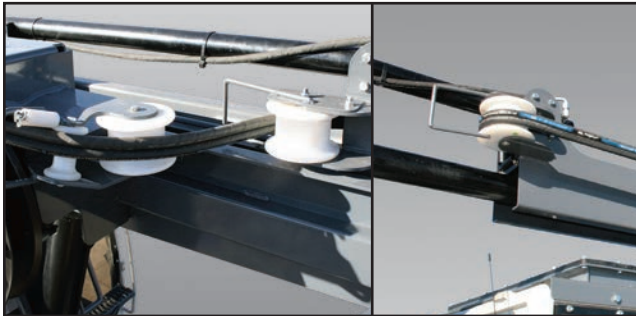

IMPORTANT: Ensure hydraulic hoses remain on guide spools when retracting the boom.

Raising And Lowering the Boom

NOTE: The boom assembly must be extracted from the transport position before the saw blade can be raised or lowered.

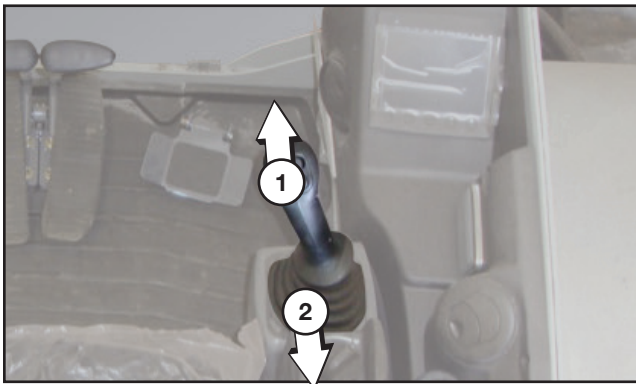

Push the right joystick forward (1) to lower the boom.

Pull the right joystick backward (2) to raise the boom.

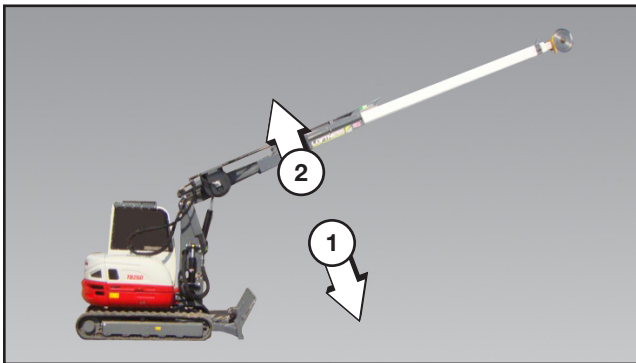

Extending and Retracting the Saw Blade

NOTE: The boom assembly must be extracted from the transport position before the saw blade can be extended and retracted.

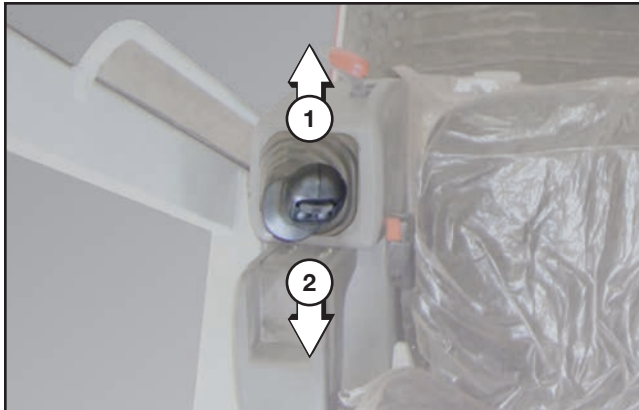

Push the left joystick forward (1) to extend the reach of the saw blade.

Pull the left joystick backward (2) to shorten the reach of the saw blade.

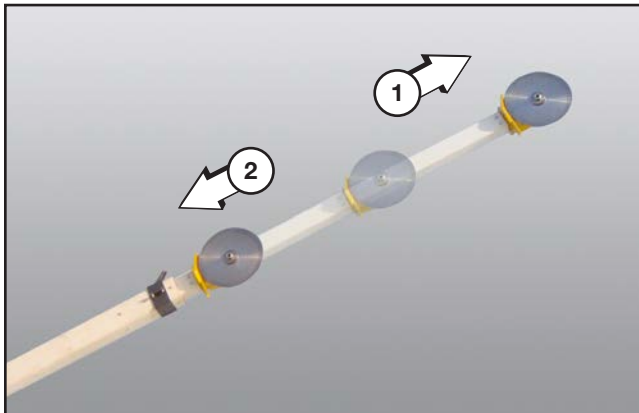

Operating Instructions

Tilting the Mast

NOTE: The boom assembly must be extended from the transport position before the saw blade can be tilted.

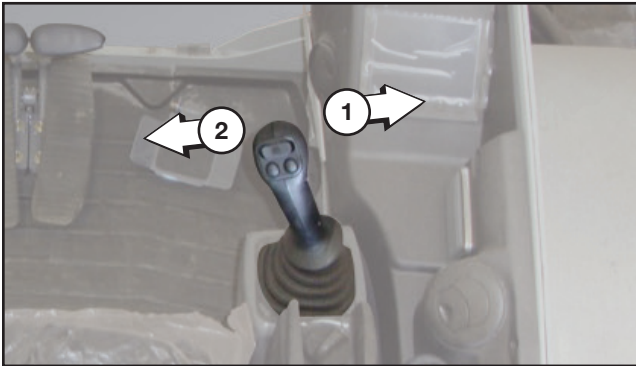

Move the right joystick to the right (1) to tilt the saw blade right.

Move the right joystick to the left (2) to tilt the saw blade left.

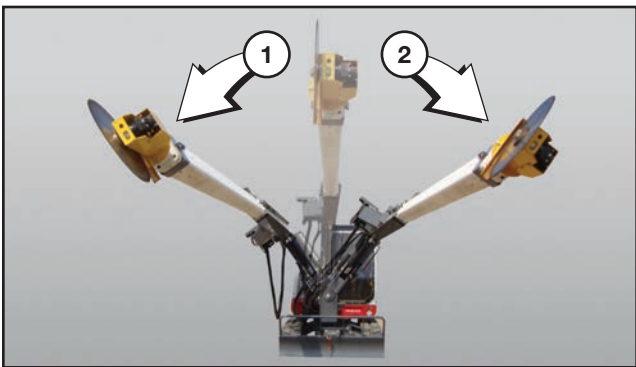

Saw Blade

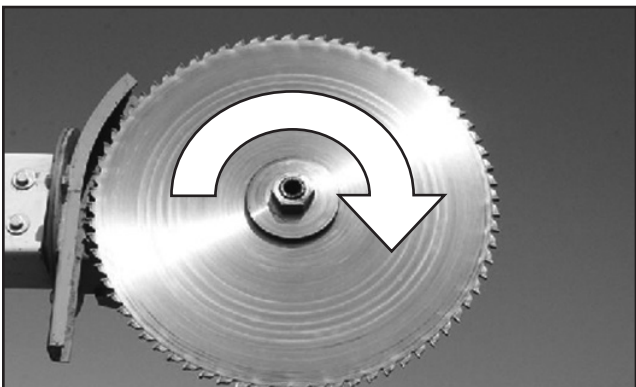

NOTE: Saw blade rotates in a forward cutting direction.

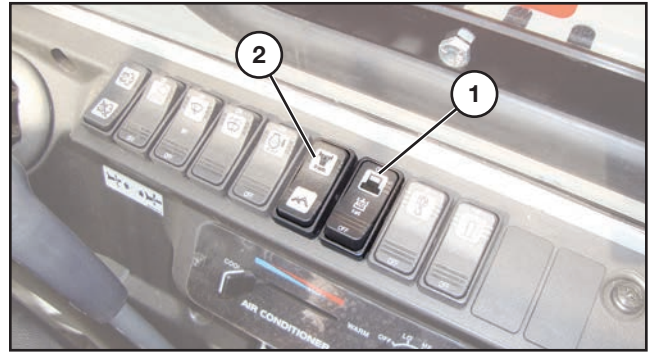

Press "AUX" button (1) to "ON" position for saw operation.

Press the "PWR" (power) button (2). This turns on the power mode, raising the engine RPM and providing maximum engine output.

Pressing the "PWR" (power) button again will turn off the power mode.



Blade will stay on when button (2) is pressed.



Turn throttle knob (3) right to increase engine RPM. Turn the knob left to decrease engine RPM.

NOTE: It is recommended to operate the Kwik Trim at full RPM (throttle).

Operating Instructions

Dozer Blade

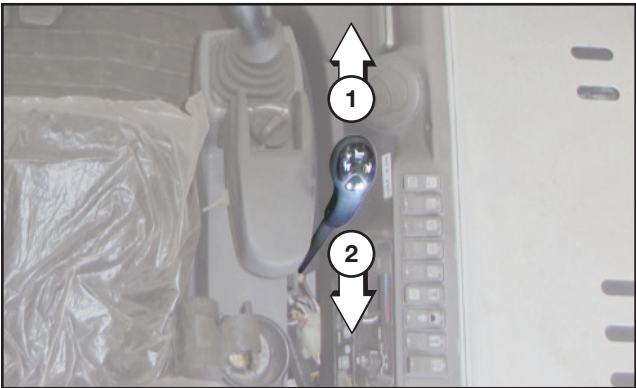

Push the lever forward (1) to lower the dozer blade. Pull the lever backward (2) to raise the dozer blade.



Winch



To unwind the winch cable, turn the top and bottom lever to the "FREE" position.

Manually pull out the required length of cable from the spool.



For low-gear operation, turn the top lever to "LOW" and leave side lever in "FREE" position.



For high-gear operation, turn the top lever to "FREE", and turn the side lever to "HIGH".

 **WARNING:** Do not move shift levers while a load is on the winch cable.

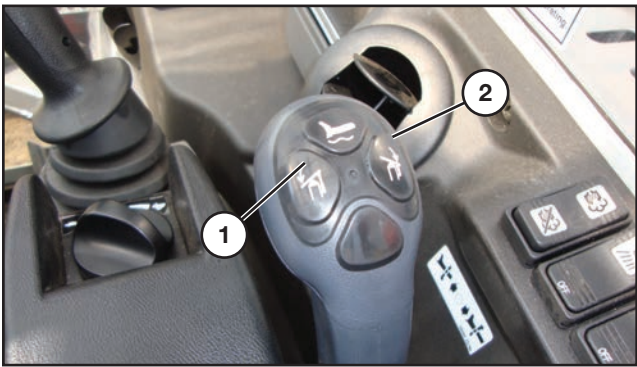

Push the "IN" button (1) to wind the winch cable. Push the "OUT" button (2) to unwind the winch cable.

Operating Instructions

Winch (Cont'd)



When finished using the winch, return the levers to the "LOCK" position.

Blade Angle Adjustment

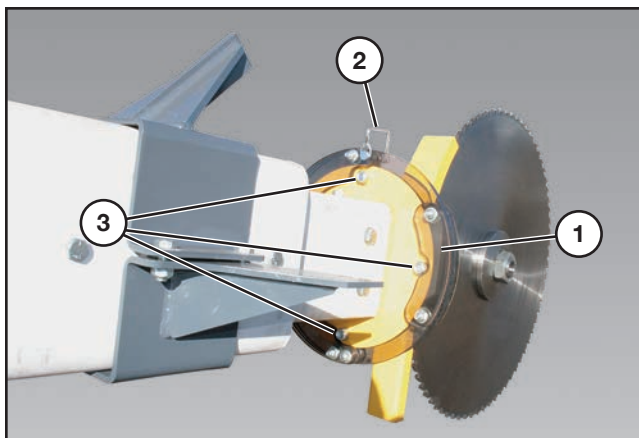

To adjust the angle of the blade to allow for horizontal cutting, attach motor mount jig (1) as shown.

Secure with retaining pin (2).

Remove the bolts, washers, and nuts (3) securing the motor/blade assembly to the boom (four places).

Rotate motor/blade assembly 90° so that the motor is positioned above the blade.

Replace and tighten fasteners.

Remove motor mount jig.

Operation

Operating The Kwik Trim

 **WARNING:** This machine should only be operated by qualified trained personnel familiar with this type of equipment and the hazards involved. Serious injury and/or death and equipment damage will result from improper or unsafe operation

 **WARNING:** Operators are responsible to be aware of safety hazard areas and follow instructions on warning, caution, or danger decals applied to the machine.

 **WARNING:** Know the area before operating the machine. Be aware of power lines, buildings or other equipment. Watch for adequate overhead clearance.

 **DANGER:** Exercise extreme caution when operating this machine in the vicinity of overhead electrical cables. The machine may become electrically charged when working in the vicinity of high frequency transmitters and cables. Do not allow any person to touch the machine from the ground while the boom is on or near electrical cables. The boom does not have to be in contact with electrical cables in order for the machine to be electrically charged. The minimum approach distance with the saw blade is 10 ft. (3 m). Failure to observe this warning could result in serious injury or death.

 **WARNING:** Stay alert at all times. Do not trim trees in dangerous weather conditions. Perform a hazard assessment of the work area before starting work. All tree trimming or removal work within 10 ft. (3 m) of power cables must be done by trained and experienced line-clearance tree trimmers.

 **WARNING:** Always have an operator in the operator's seat while the machine is in operation.

Operating Instructions

Operating The Kwik Trim (Cont'd)



WARNING: Keep children, bystanders and other workers away from the machine while it is operating. No riders allowed.

Move the machine to work area. See the machine's Owner's Manual for detailed information on operating the machine.

Position the machine so that the trees to be trimmed are on the right side of the machine. Positioning the machine in this manner, uncut limbs will not limit the visibility of the operator and the saw motor and saw frame will not hang up on the tree trunk or limbs. Approaching the tree in any other manner will subject the saw motor and saw frame to undue damage and wear. After the machine is in position for the first cut, stop the machine.

Lower the dozer blade to stabilize the machine.

NOTE: If the terrain slopes significantly, tilt the boom to the uphill side of the slope. This will help stabilize the machine to reduce the possibility of a rollover and allow a 90° cut on the tree limbs.



WARNING: When trimming trees in dense forest where visibility may be limited, always position personnel in sight of the operator to warn operator of hazards, possible collisions or unauthorized personnel in trimming area.



WARNING: Always close and latch the cab door before trimming trees. Falling limbs, debris, and saw fragments may enter the cab causing serious injury or death.

Increase engine RPM fully.

Position the saw blade for the first cut. Start saw blade rotation.

NOTE: It's recommended to start trimming limbs nearest the operator and work from the bottom of tree to the top.

NOTE: Avoid rubbing the boom on lower limbs while working up the tree. Rubbing the boom on the tree or limbs will result in damage to the boom and structural weakening of the boom.

Small Limbs - A straight forward cut can be made with the saw by extending the boom until it contacts and cuts through the limb.

Large Limbs - Always cut larger limbs from the top down to avoid binding the saw blade and causing damage to the saw blade and motor.



WARNING: If the saw blade becomes lodged or pinched in the cut, DO NOT try to dislodge by pushing or pulling with the track drive. Serious damage to the Kwik Trim components can result.



WARNING: Full extension of the boom should be used to reach the highest limbs, NOT to extend the horizontal reach of the machine. Fully extending the boom in the horizontal position to trim limbs may result in damage to the structure of the boom.



WARNING: Avoid overextending the boom while cutting if the boom is horizontal or below horizontal. Boom life could be shortened by extending the boom horizontally excessively as a regular practice while trimming limbs.



WARNING: AVOID WHIPPING THE BOOM UP AND DOWN QUICKLY. Whipping the boom up and down quickly will result in breaking fibers in the boom.

NOTE: The operator may need to experiment to determine the best cutting procedures for individual situations.

NOTE: Cutting speed depends on size of limbs, density of growth, type of trees and the terrain.

When trimming is complete, stop saw blade rotation, retract and lower the boom, raise the dozer blade and move the machine to the next trimming location. Lower the dozer blade and continue trimming.

Operating Instructions

Operating The Kwik Trim on a Slope

All machines have a center of gravity. This is a calculated point, normally within the structure of the machine, about which all the weight of the machine is distributed.

NOTE: *When the center of gravity of the machine passes beyond an imaginary line drawn vertically from the furthestmost point of support of the tracks, the machine will tip-over or roll-over.*



WARNING: *When operating the Kwik Trim on a slope:*

- *The extent to which the machine can operate safely on slopes will depend on the expertise of the operator and operator's familiarity with the machine.*
- *Under actual operating conditions, the slope of the terrain is continually changing and sudden local variations may result in slopes which exceed operational limit guidelines although the overall slope of the terrain may be within safe operation limits.*
- *Adapt operation of the machine to actual terrain conditions.*
- *Failure to do so could lead to loss of control and possible serious injuries or death.*

While limits can be determined with accuracy under ideal conditions, the skill of the operator, the position of the machine upper structure and actual terrain conditions constantly influence and change these limits during operation of the machine.

The operator must evaluate every situation carefully and as a separate case. Never assume the machine can cross a certain part of terrain because it has traveled there before or because the terrain appears to be safe.

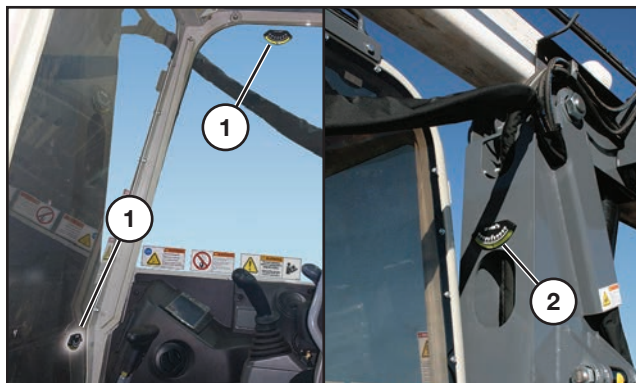

Use the inclinometers for reference to gauge safe operation when operating on a slope.

Two inclinometers are also located inside the cab (1), and one is located outside the cab (2) on the mast, visible from the cab seat.

Switching to Transport Position

Transport Position



Stop saw blade rotation. See “Saw Blade” on page 16.

Center the boom on the machine. See “Tilting the Mast” on page 16.

Lower and Retract Boom

Raise or lower the boom until parallel with the ground. See “Raising And Lowering the Boom” on page 15. Retract saw blade, refer to “Extending and Retracting the Saw Blade” on page 15

Fully retract the boom. Refer to “Extending And Retracting the Boom from and to Transport Position”, and “Retracting Boom to Transport Position” on page 14.

Raise the dozer blade. See “Dozer Blade” on page 17.

Operating Instructions

Service Steps

Climbing Service Steps



Use the service step to access top of machine for service and maintenance.



WARNING: Do not climb the service steps while the machine is in operation.

Loading And Unloading

Loading



WARNING: When operating the Kwik Trim on a slope:

- Select a firm, level surface and keep sufficient distance from road shoulders.
- Secure ramps of adequate strength and size to the truck bed/trailer. The slope of the ramps must not exceed 15°.
- Never use the working equipment to load or unload the machine. Doing so may result in tipping over or falling down of the machine.
- Keep the truck bed/trailer and loading ramps clean of oil, soil, ice, snow, and other materials to prevent the machine from sliding sideways. Clean the crawlers.
- Chock the transporter wheels to prevent movement.
- Turn off the deceleration switch and autodeceleration switch. Otherwise, the engine speed may suddenly increase to cause troubles (for machines with the deceleration and auto-deceleration switches).
- When being loaded or unloaded, travel slowly in 1st (low) gear by following the signal from the signal person.
- Never change courses on the ramps.
- Do not slew on the ramps. The machine may tip over.
- When slewing on the truck bed, do it slowly as the footing may be unstable.



General Maintenance

To ensure efficient operation, you should inspect, lubricate, and make necessary adjustments and repairs at regular intervals. Parts that are starting to show wear should be ordered ahead of time, before a costly breakdown occurs and you have to wait for replacement parts. Keep good maintenance records, and adequately clean your machine after each use.

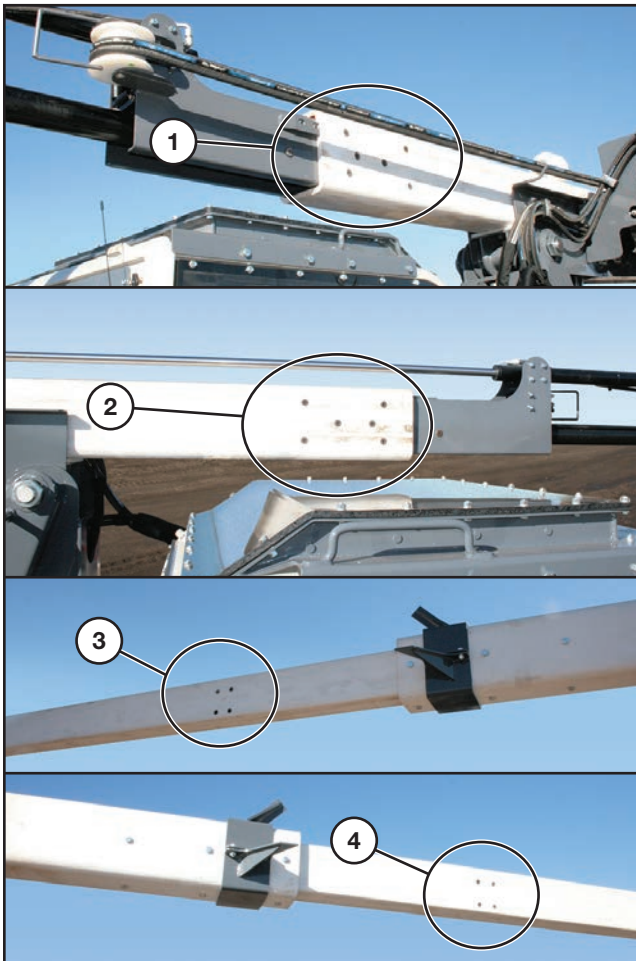

Periodically check countersunk bolts on the fiberglass boom for tightness at these locations:

Rear of boom, six on the right side (1) and six on the left side (2).

And with boom fully extended, four on the right side (3) and four on the left side (4).

If any bolts are loose, remove the bolt and add high-strength Loctite® to threads. Reinsert bolt and tighten.

Fluids And Lubricants

Proper lubrication is important. Too little lubricant will cause premature failure of a bearing. Too much lubrication usually causes high operating temperature and early failure of seals. Follow all lubrication instructions and schedules included in this section.

1. Grease - Use an SAE multipurpose high temperature grease with extreme-pressure (EP) rating. Also acceptable is an SAE multipurpose lithium based grease.
2. Storing Lubricants - Your machine can operate at top efficiency only if clean lubricants are used. Use clean containers to handle all lubricants. Store them in an area protected from dust, moisture and other contaminants.
3. Use Hydraulic Oil - Cenex INDOL-MV or equivalent.
3. Hydraulic fluid used must meet Dielectric strength ASTM D 877. Some options include:
 - Cenex INDOL-MV
 - Shell Tellus S2 V 32
 - Mobil DTE Excel

Maintenance

Lubrication

Grease Points

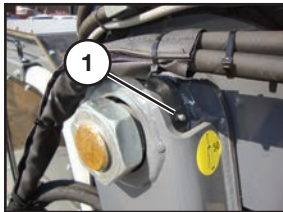

Boom Pivot, right

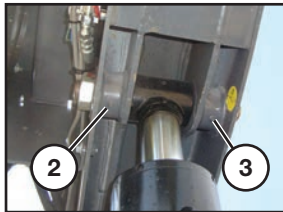

Boom Cylinder, upper

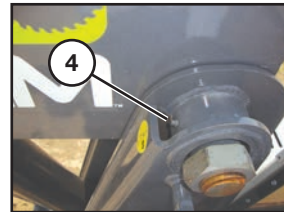

Boom Pivot, left

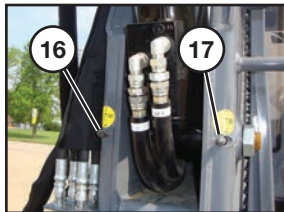

Boom Cylinder, lower

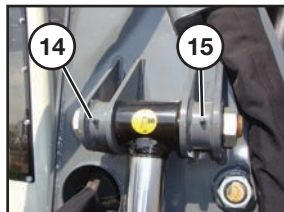

Mast Cylinder, upper

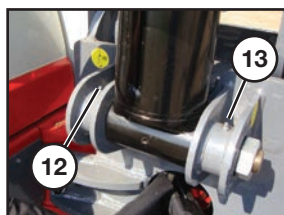

Mast Cylinder, lower

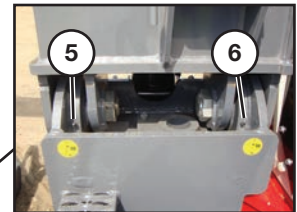

Mast Pivot

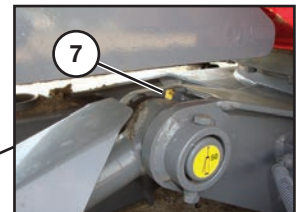

Dozer Cylinder, rear

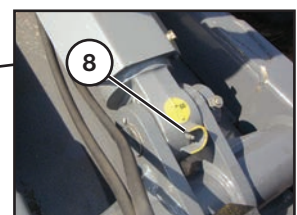

Dozer Cylinder, front

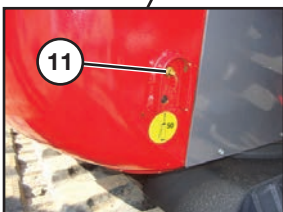

Slew Drive

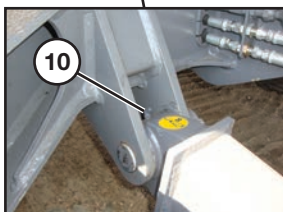

Dozer Pivot, right

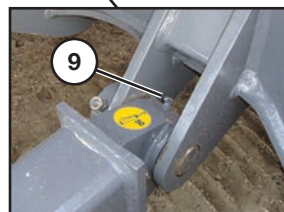

Dozer Pivot, left

Grease Points (Cont'd)

Use an SAE multipurpose high temperature grease with extreme-pressure (EP) rating. Also acceptable is an SAE multipurpose lithium based grease.

NOTE: Replace any broken or missing grease fittings. Be sure to clean fittings before greasing.

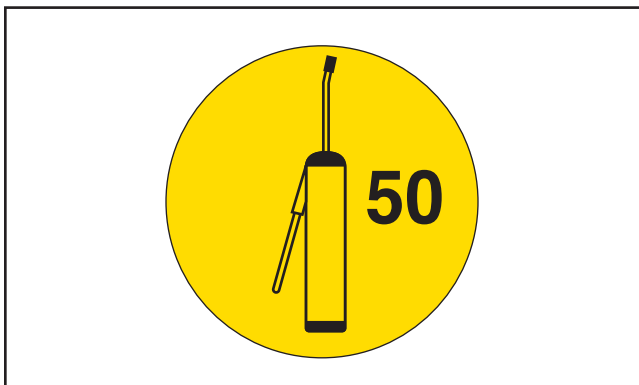

NOTE: Lubricate the grease point every "X" hours indicated on the decal adjacent to the grease point (shown here as 50 hours).

Numbers below after "Location" correspond to grease point locations on opposite page.

• Boom Pivot

Location: Right (1) and left (4).

Interval: Every 50 hours of operation.

• Boom Lift Cylinder

Location: Rod end (2) and (3); base end (16) and (17).

Interval: Every 50 hours of operation.

• Mast Pivot

Location: Front (5) and rear (6).

Interval: Every 50 hours of operation.

• Dozer Lift Cylinder

Location: Rod end (7); base end (8).

Interval: Every 50 hours of operation.

• Dozer Pivot

Location: Left (9) and right (10).

Interval: Every 50 hours of operation.

• Slew Drive

Location: Front of excavator (11).

Interval: Every 50 hours of operation.

• Mast Cylinder

Location: Base end (12) and (13); rod end (14) and (15).

Interval: Every 50 hours of operation.

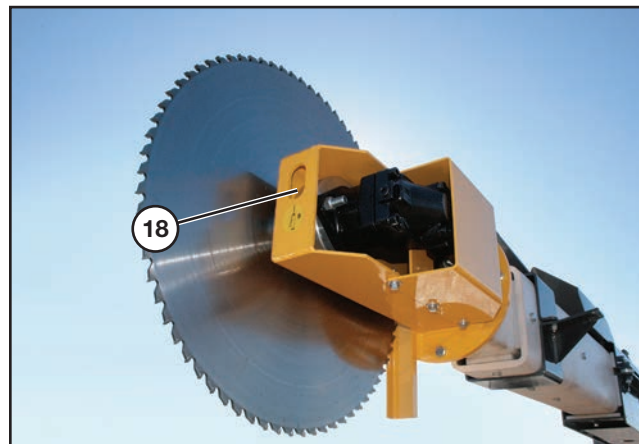

• Saw Blade Bearing

Location: (18).

Interval: Every 8 hours of operation.

Releasing Hydraulic Pressure

Release hydraulic pressure. See the excavator's Operation & Maintenance Manual and Operator's Handbook for detailed information on operating the excavator.

Maintenance

Saw Blade

Blade Inspection

	WARNING: <i>Never attempt to make any adjustments while the excavator engine is running or the key is in the “ON” position in the excavator. Before leaving the operator’s position, disengage power to the machine and remove ignition key.</i>
---	---

Park the machine on a flat, rigid and safe ground.

Lower the dozer blade to the ground.

Fully extend the boom.

Fully lower the boom.

Release hydraulic pressure. See the machine’s “Owner’s Manual” for correct procedure.

Set the parking brake and exit the machine. See “Exiting The Machine” on page 13.

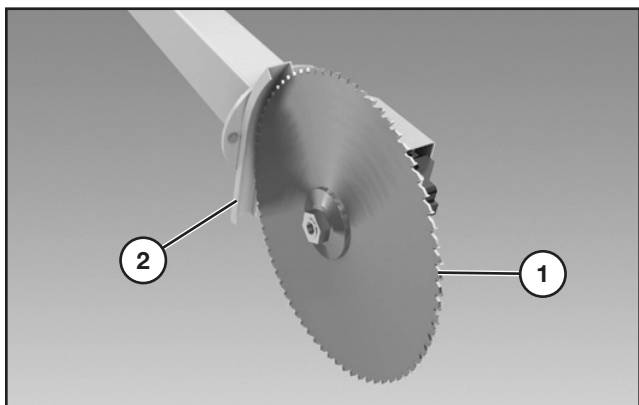

Inspect the saw blade teeth (1) for wear or damage after eight hours of operation or daily. Replace or sharpen if necessary.

Inspect the blade guard (2) for damage.

NOTE: *The industry standard 24 in. (609.6 mm) carbide-tipped saw blade teeth can be re-sharpened.*

Blade Removal

	WARNING: <i>Never attempt to make any adjustments while the excavator engine is running or the key is in the “ON” position in the excavator. Before leaving the operator’s position, disengage power to the machine and remove ignition key.</i>
---	---

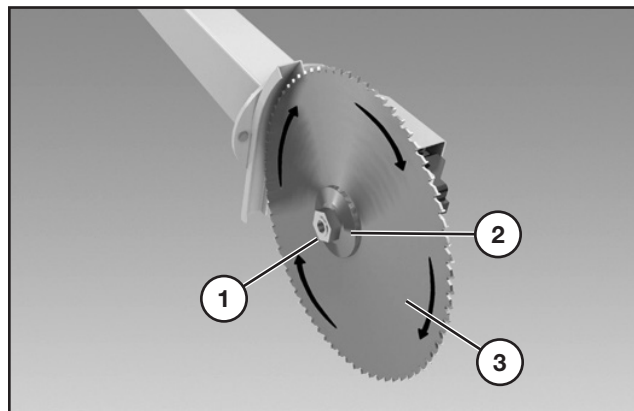

Remove the nut (left-hand thread) (1), washer (2) and blade (3).

NOTE: *The saw blade rotates in a forward cutting direction.*

Blade Installation

Install the replacement blade in a forward cutting direction.

Boom

Care And Maintenance

NOTE: *A dirty boom does not shed rain as well and can cause failure of di-electrical tests.*

NOTE: *Do Not perform a boom di-electrical test while the boom is wet as this can cause permanent damage.*

Park the machine on flat level surface, lower the dozer blade and extend the boom to the operation position.

Lower boom fully to allow the water to drain out of the boom.

Turn engine off and exit the machine.

NOTE: *Do Not use a pressure washer. High pressure can cause water to diffuse through the fiberglass fibers.*

NOTE: *Abrasives and solvents cleaners are not recommended as they can scratch or soften the surface coatings.*

Wash the boom by hand using soap and water only.

Electrical Conductivity Test

It is highly recommended that the boom be tested to electrical conductivity every six months to insure operator safety when working around high voltage.

This di-electric test should be conducted in accordance with ANSI A92.2-2001 Category C.

Di-electric testing at over 1mA (1000 micro-amps) return current can cause harm to the boom by causing the boom to burn. If during the di-electric test, the return current is close to 1000 micro-amps, stop the test immediately and examine the boom for hot spots. Examine the boom for any contamination such as dirt, moisture, sticks and other debris. Let the boom cool and remove contamination.

NOTE: *Dirt or moisture can cause the boom to be burnt beyond repair.*

Boom Inspection And Repairs

Inspect the boom surface for cracks due to weather, age or improper paint preparations as these can cause boom failure.

NOTE: *Refinishing the exterior of the boom without masking the interior can cause paint overspray to settle on the inside. This overspray will trap moisture and prevent water from beading on this rough surface. The trapped moisture can lead to failed di-electric tests.*

NOTE: *Over loading the boom can cause stress cracks and shorten the life of the boom. A single overload can shorten service life by months or years. A boom used as recommended should remain in service for many years. A boom may be overloaded by jamming it against trees or putting it in a bind.*

Cuts And Abrasions - Cut and abrasions caused by rubbing the boom on the side of trees etc. can weaken the boom in the specific area of the damage. Consult Loftness before attempting repair.

Sunshine And Ultraviolet Radiation - Sunlight and UV can damage an unpainted area of a boom causing. The exposed area to look fuzzy as the fibers are exposed. Repair surface scratches to seal out the sun and moisture to prevent damage to the boom.

Improper Repairs - Using substandard material and improper repair procedures can result in boom damage. There are two types of repairs:

1. Periodic surface repairs that involves the outside coating.
2. Structural repairs that involve the boom itself.

Structural repairs should be referred to Loftness for a case by case study.

Examples of structural repairs include cracks, cuts, delamination and impact damage from tree limbs or tools.

Maintenance

Installing New Hose Reel Hoses

Retract inner boom all the way in.

Turn off the mini excavator to remove all power to the Kwik Trim.

	DANGER: Failure to turn off power to the Kwik Trim before performing this procedure could result in serious injury or death.
---	---

NOTE: Always replace both hoses when installing new hose on the hose reel.

Pull some hose out of the hose reel and install a vise grip on disc by mounting base to hold reel from retracting.

Mark hoses before removing from inner boom bulkhead. Viewed from operator's position in cab: the **left hand side** of inner boom is the pressure hose. the **right hand side** of inner boom is the return hose.

Pull hoses completely off of reel and re-clamp to hold tension. Remove both hoses. Hose reel tension can be reset by unwinding and starting over with tension.

Install inside hose (Loftness part no. N28892 - Pressure 286 in.). Gates MegaTuff® hose is recommended (Gates 8M3K-MTF-8FJIC-10FJIC-286"). First on inside main shaft fitting closest to spring. Make sure to hold metal line fitting on main shaft with a wrench. After tightening hose, let reel retract hose (counterclockwise facing hose swivel) until outside main shaft fitting is visible, then re-clamp hose reel.

Install outside hose (Loftness part no. N28891 – Tank 270 in.). Gates MegaTuff® hose is recommended. (Gates

M3K-MTF-8JIC-10JIC-270"). Let hoses retract in and re-clamp to leave enough hose to connect to bulkhead on inner boom.

Reinstall hoses on inner boom bulkhead. Make sure there are no twists in the hoses or the hoses will not wrap on hose reel properly.

IMPORTANT: Hold hose fitting when tightening hose swivel end.

Viewed from operator's position in cab: the **left hand side** of inner boom bulkhead is pressure. the **right hand side** of inner boom bulkhead is return.

Remove clamp on hose reel. Operate inner boom in and out, watching hoses to make sure there is proper tension and there are no twists or binding in the hoses.

Adding Tension

If hoses need more tension, remove cover on spring housing (3 small screws).

Facing spring housing, use a spanner wrench and turn counter clockwise one half revolution and recheck hose tension.

Repeat procedure if more tension is needed, making sure to rotate wrench no more than one half revolution each time.

NOTE: Reels are preset from factory with four (4) full turns of tension. The maximum number of turns allowed is six (6).

If reel tension was released completely, start with four (4) turns of tension and check hose tension after each cycle.

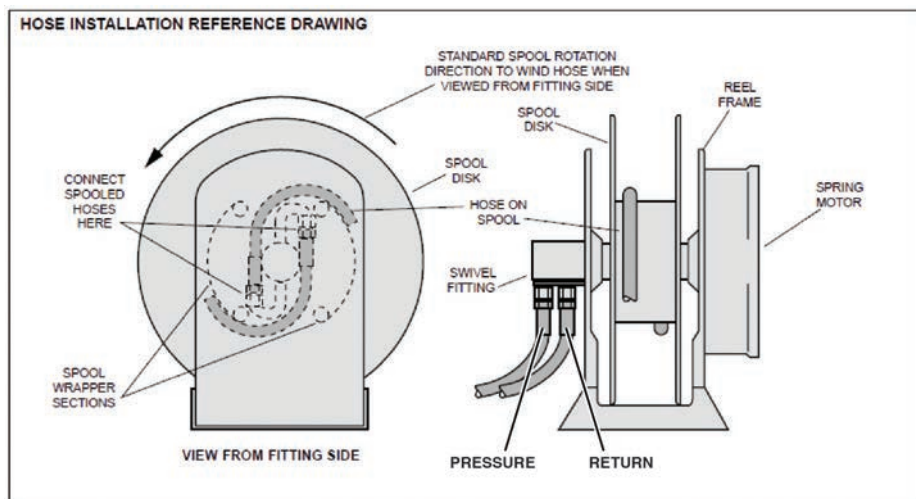

Troubleshooting

PROBLEM	POSSIBLE CAUSE	SOLUTION
In work position, boom will not lift or extend, or saw blade will “creep” when turned off.	Boom sensor switch is stuck in.	Free plunger on boom sensor switch.
	Boom sensor switch is out of adjustment.	Readjust sensor.
	Solenoid not energized.	Possible faulty sensor. Replace sensor.
	Faulty sensor switch.	Replace sensor switch.
	Faulty solenoid.	Replace solenoid.
Boom will not move into or out of transport position.	Lift sensor switch is not making contact.	Adjust sensor to engage with boom level.
	Bad fuse.	Replace if needed.
	Low voltage supply.	Check ground wiring and voltage to ensure 12 volts is being supplied. Black power wire from inside cab (in panel below seat) to sensor switch black wire. Blue wire on sensor switch to red wire on solenoid.
	Faulty sensor switch.	Replace sensor switch.
	Faulty solenoid.	Replace solenoid.
Boom lift or tilt cylinders settle.	Leaking fitting or hose.	Check for leaks from valve stack to cylinder.
	Faulty counter balance valve (CBV) cartridge.	Support the weight of the boom and switch cartridges. Check if works. Replace counter balance valve (CBV) cartridge.
	Internal leakage of cylinder.	Repair cylinder.
Boom extend cylinder is slow.	Debris in counter balance valve (CBV) cartridge (return side).	Clean cartridge and pilot ports.
Boom lifts in while in transport position.	Boom sensor switch is not making contact.	Adjust sensor to engage.
	Bad fuse.	Replace if needed.
	Low voltage supply.	Check ground wiring and voltage to ensure 12 volts is being supplied. Black power wire from inside cab (in panel below seat) to switch black wire. Blue wire on switch to red wire on solenoid.
	Faulty sensor switch.	Replace sensor switch.
	Faulty solenoid.	Replace solenoid.

Maintenance

Troubleshooting (Cont'd)

PROBLEM	POSSIBLE CAUSE	SOLUTION
Saw blade will not spin.	Bad fuse.	Replace if needed.
Saw blade vibration.	Saw blade loose or worn.	Replace or repair if necessary.
	Saw blade bent or damaged.	Replace blade.
	Saw blade bearing damaged.	Replace bearing.
Motor for saw has leak.	Shaft seal on motor has blown.	Check return oil lines for possible pinched hose and replace shaft seal.
NOTE: See the machine's "Owner's Manual" for additional troubleshooting procedures.		



PARTS IDENTIFICATION AND HYDRAULIC SCHEMATICS

Parts Identification

Kwik Trim Assembly

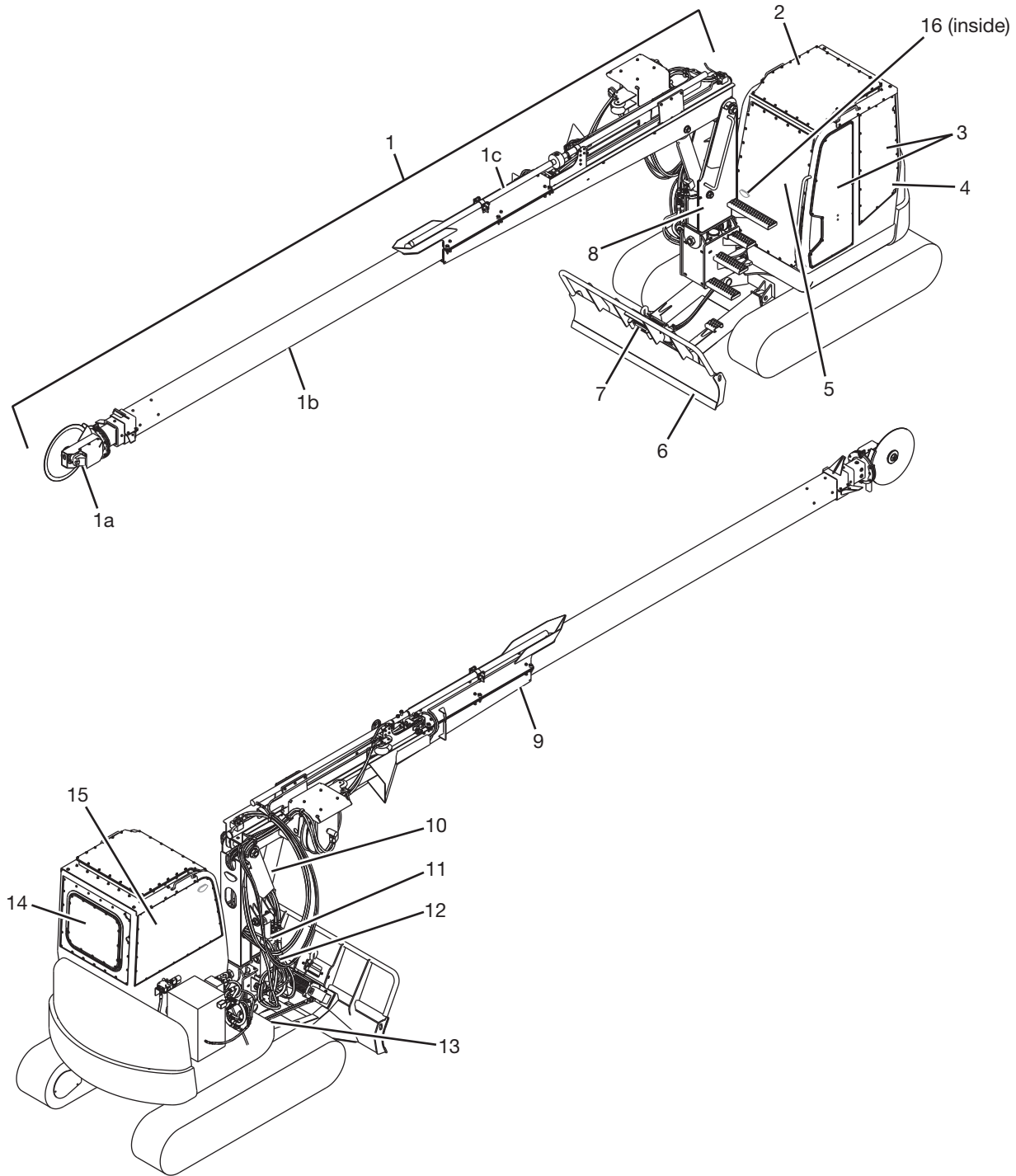

Kwik Trim Assembly

#	QTY.	PART #	DESCRIPTION
1	1	N38189	BOOM ASSEMBLY (See page 36)
1a	1	N24594	MOTOR ASSEMBLY (See page 47)
1b	1	N24496	TUBE, W/SLIDES INNER (See page 44)
1c	1	N38192	TUBE, OUTER W/SLIDES (See page 42)
2	1	N129683	TOP COVER ASSEMBLY (See page 70)
3	1	Assembly	WINDOWS, SIDE (See page 66)
4	1	N28326	FIRE EXTINGUISHER (See page 74)
5	1	Assembly	WINDOW, FRONT (See page 66)
6	1	N38071	BLADE, WELDMENT TB260 (See page 72)
7	1	N28190	HYDRAULICS, WINCH (See page 60)
8	1	N38144	MAST, BOOM MOUNT (See page 35)
9	1	N38178	CRADLE ASSEMBLY (See page 46)
10	1	N28733	LIFT CYLINDER (See page 50)
11	1	N28732	TILT CYLINDER (See page 50)
12	1	Assembly	HYDRAULICS (See page 50)
13	1	N38356	COVER PLATE (See page 73)
14	1	N105428	WINDOW, ESCAPE (See page 69)
15	1	N105416	WINDOW, RIGHT (See page 68)
16	2	N118561	INCLINOMETER, 3.5 X 1.6 45DEG (Both inside. One on front panel and one on side panel.)

Parts Identification

Mast, Boom Mount

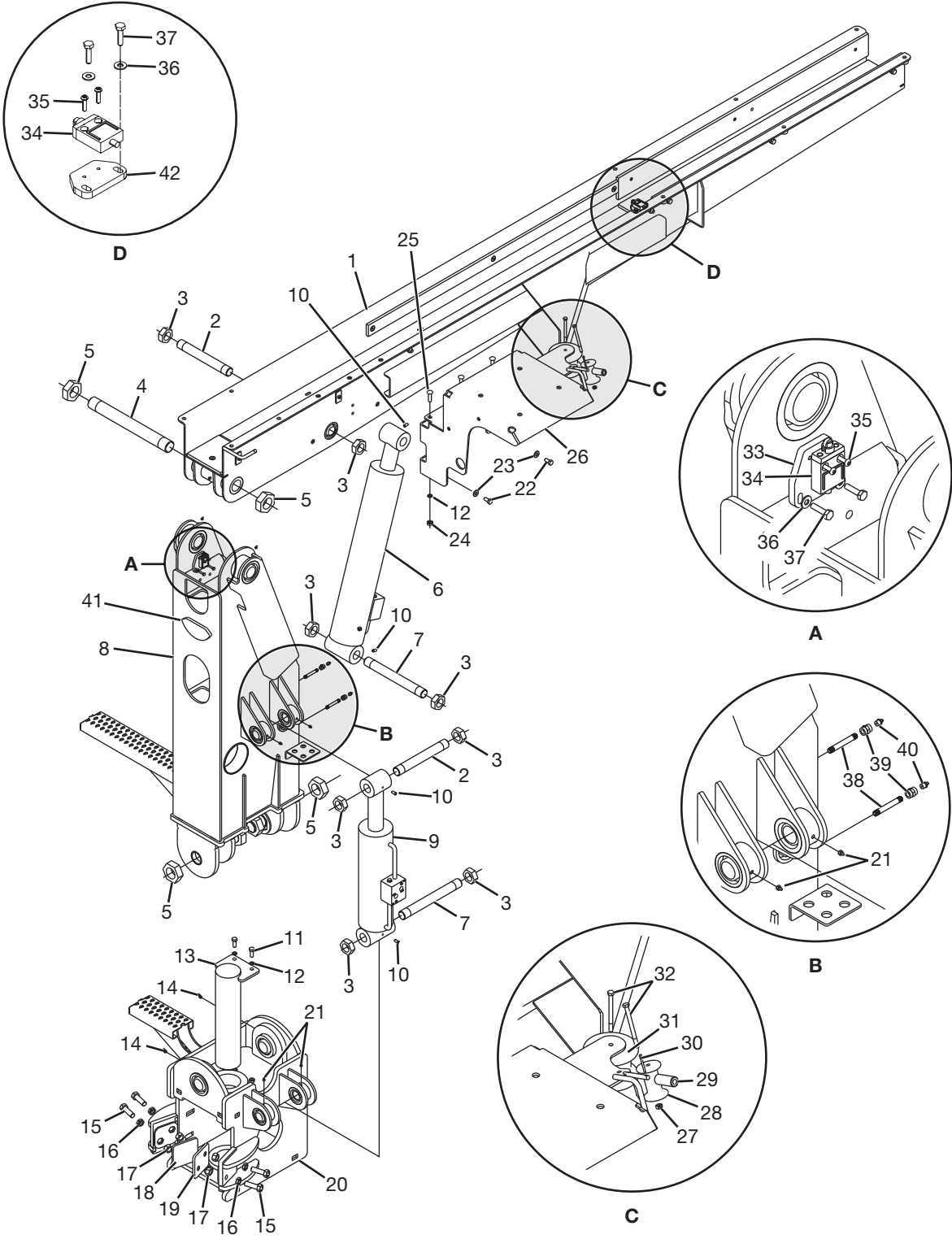

Parts Identification

Mast, Boom Mount

#	QTY.	PART #	DESCRIPTION
1	1	N38178	CRADLE, ASSY W/SLIDES
2	2	N24542	PIN, 1.50" X 11.5" 6 UNC-2A
3	8	N24541	NUT, JAM 1-1/2 PLATED
4	1	N24512	PIN, 2" X 16" 4-1/2 UNC-2A
5	4	N24515	NUT, JAM 2" 4-1/2 PLATED
6	1	N28733	CYLINDER, 5" X 24" CNTERBLNCE
7	2	N24540	PIN, 1.50" X 13.25" 6 UNC-2A
8	1	N38144	MAST
9	1	N28732	CYLINDER, 5" X 12" CNTERBLNCE
10	4	N22210	SCREW,3/8-16 X 3/4 SCKT HD SET
11	2	4012	BOLT, 1/2" X 1-1/4" GRADE 5
12	5	N16472	WASHER, 1/2 NORDLOCK
13	1	N24528	PIN, MOUNT BASE
14	2	4106	GREASEZERK,45 DEG SCW-IN 1/8NPT
15	4	N129768	BOLT, SHCS 3/4 X FN THD
16	4	4998	NUT, 3/4" JAM FN THRD
17	4	4341	NUT, 3/4" FINE THREAD GRADE 8
18	1	N38131	PLATE, ROTATION LOCK
19	1	N38153	PLATE, ROTATION LOCK
20	1	N38100	MOUNT, WELDMENT
21	6	N17007	GREASE-ZERK, 1/4" SCREW-IN
22	5	4011	BOLT, 1/2" X 1" GRADE 5
23	2	4486	WASHER, 1/2" FLAT
24	3	4250	NUT, STANDARD 1/2 (BOTTOM)
25	3	4038	BOLT, CARRIAGE 1/2" X 1-1/4" (TOP)
26	1	N38199	MOUNT, WELDMENT HOSE REEL
27	2	4052	NUT, LOCK 3/8"
28	1	N38206	ROLLER, HOSE
29	1	N55374	ROLLER, HOSE GUIDE
30	1	4325	PIN, COTTER 3/16" X 1-1/2"
31	1	N38201	ROLLER, HOSE
32	2	4455	BOLT, 3/8" X 4-1/2" GRADE 5
33	1	N38195	PLATE, SWITCH MAST
34	2	N38174	SWITCH, ROLL PLUNGE LOW PROF
35	4	N22358	BOLT, #10-32 X 3/4" BHCS
36	4	4460	WASHER, 1/4" SAE FLAT
37	4	4000	BOLT, 1/4" X 1" GRADE 5
38	2	N38126	NIPPLE, 1/8 X 3
39	2	N38128	COUPLING, 1/8 PIPE
40	2	N17007	GREASEZERK, 1/8" NPT
41	1	N118559	INCLINOMETER, 6.4 X 2.9 50DEG
42	1	N38197	PLATE, SWITCH MAST

Parts Identification

Boom Assembly (N38189)

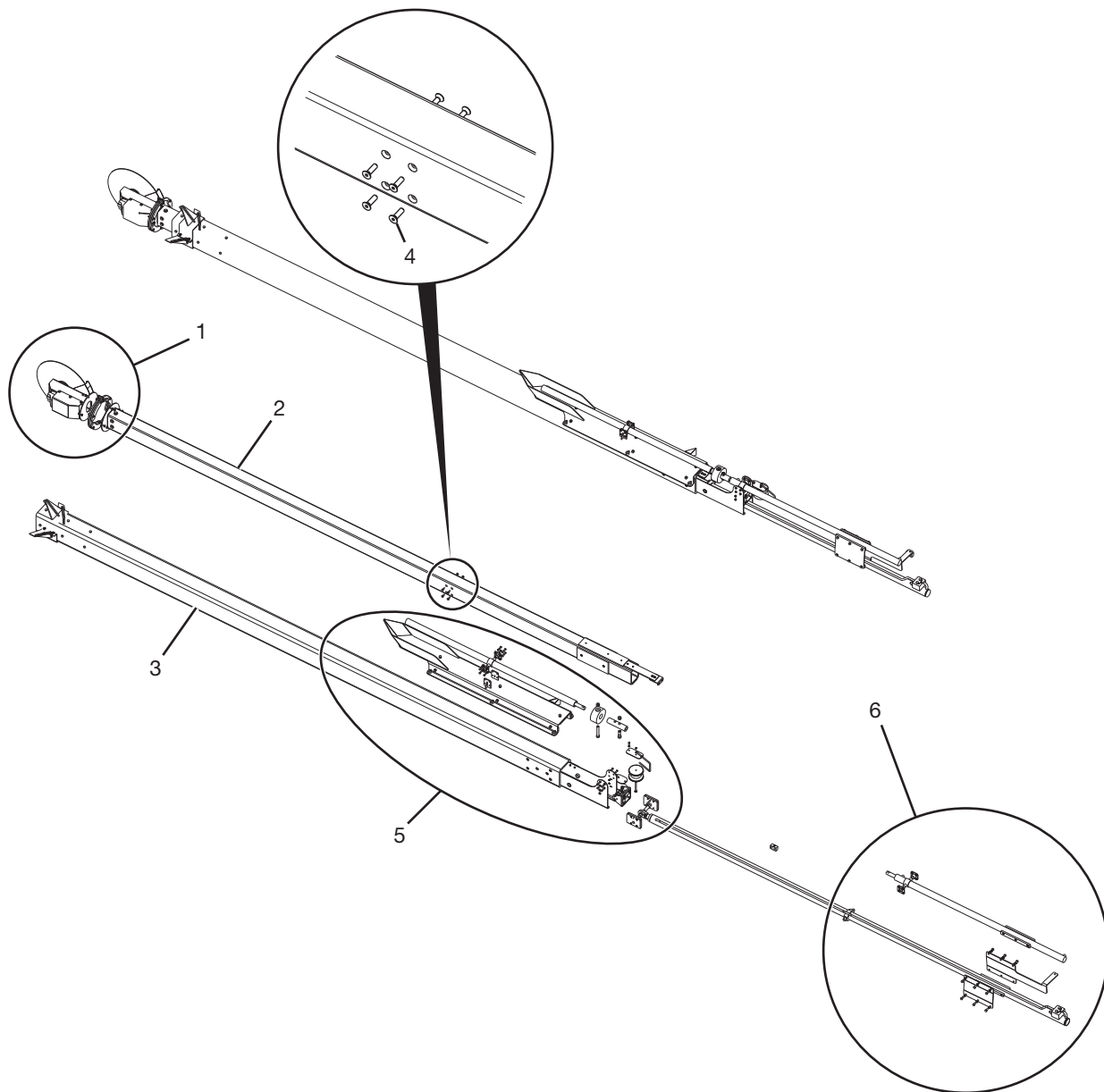

#	QTY.	PART #	DESCRIPTION
1	1	N38189	BOOM ASSEMBLY (See page 40)
2	1	N24496	TUBE, W/SLIDES INNER (See page 44)
3	1	N38192	TUBE, OUTER W/SLIDES (See page 43)
4	8	N24810	SCREW, FHCS 3/8-16 UNC X 1-1/4
5	1	N38189	BOOM ASSEMBLY (See page 38)
6	1	N38189	BOOM ASSEMBLY (See page 37)

Boom Assembly (N38189)

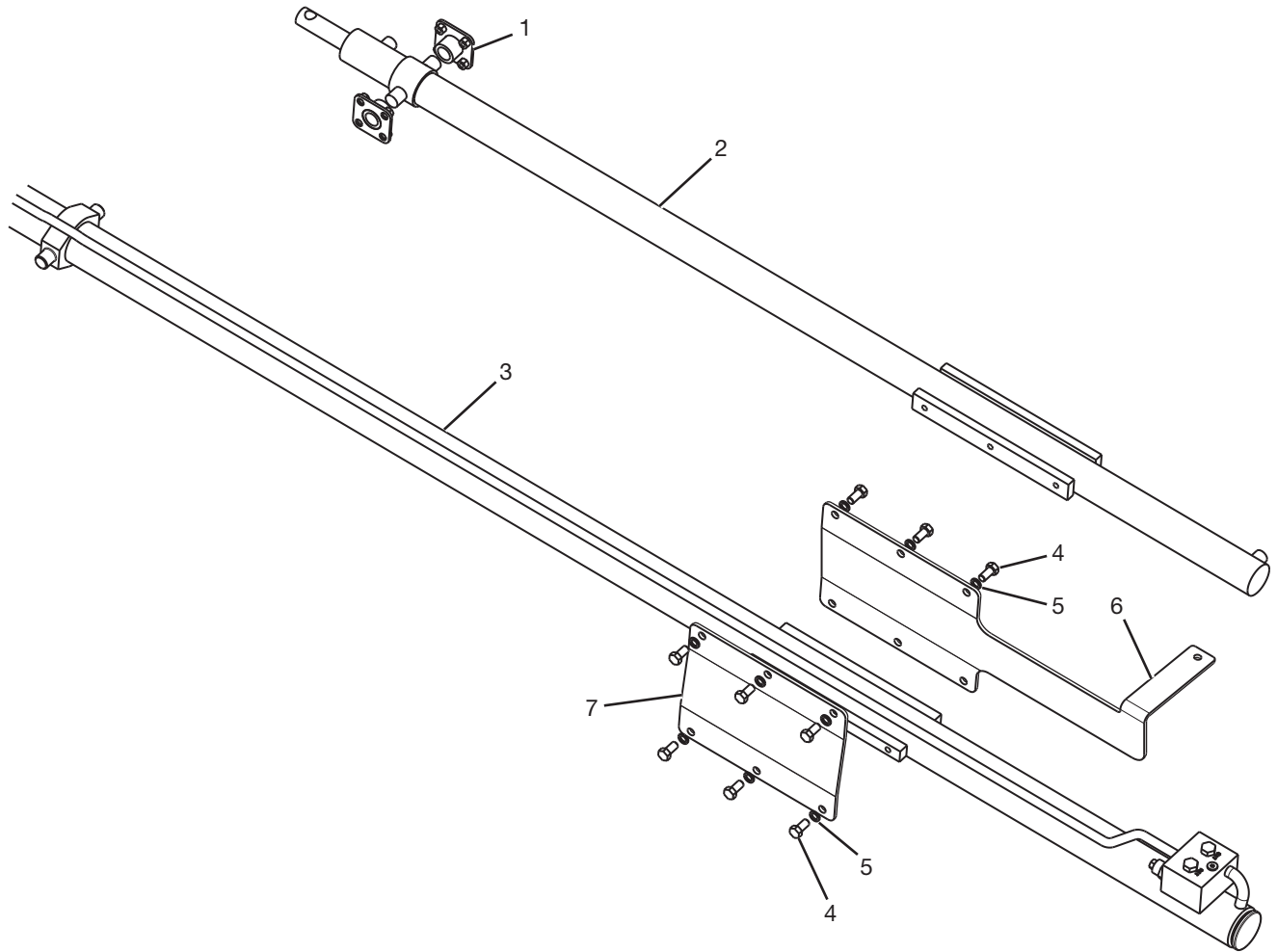

#	QTY.	PART #	DESCRIPTION
1	2	N24850	MOUNT, WELDMENT TRUNNION
2	1	N24629	CYLINDER, 2" BORE 72" STROKE
3	1	N28746	CYLINDER, 2-1/2" X 175" STROKE
4	12	4011	BOLT, 1/2" X 1" GRADE 5
5	12	N16472	WASHER, 1/2" NORDLOCK
6	1	N38323	PLATE, CYLINDER BOOM
7	1	N38212	PLATE, CYLINDER BOOM

Parts Identification

Boom Assembly (N38189) (Cont'd)

#	QTY.	PART #	DESCRIPTION
1	1	N38185	CLAMP, CRADLE TOP W/SLIDES (See page 45)
2	1	N24639	CYLINDER, 2" BORE 72" STROKE
3	2	N24612	MOUNT, TRUNNION TRANS FRONT
4	21	4195	BOLT, 3/8" X 1" GRADE 5
5	17	N16470	WASHER, 3/8 NORDLOCK
6	2	4056	NUT, LOCK 3/4"
7	1	N28317	BUSHING, CYLINDER COUPLER
8	1	4276	BOLT, 3/4" X 5" GR. 5
9	1	N24610	COUPLER, CYLINDER 1.25 ROD
10	1	4028	BOLT, 3/4 X 2-3/4 GRADE 5
11	1	N128942	BOLT, CARRIAGE 3/8 X 5
12	1	N38201	ROLLER, HOSE
13	1	4052	NUT, LOCK 3/8"
14	2	207764	PLATE, MOUNT ROD END WITH SET SCREW
15	1	N24620	ROD, HOSE SUPPORT
16	2	N28272	BUSHING, 1.01ID X 1.25ODX.682
17	1	N24490	PIN, 1.25 X 4.125
18	1	N28614	ROLLER, ASSY FAIRLEAD
18a	2	N28701	ROLLER, 2" HANNAY FAIRLEAD
18b	2	N28702	ROLLER, 2.5" HANNAY FAIRLEAD
19	4	4064	WASHER, FLAT 3/8"
20	1	N149618	GUIDE, HOSE

Parts Identification

Boom Assembly (N38189) (Cont'd)

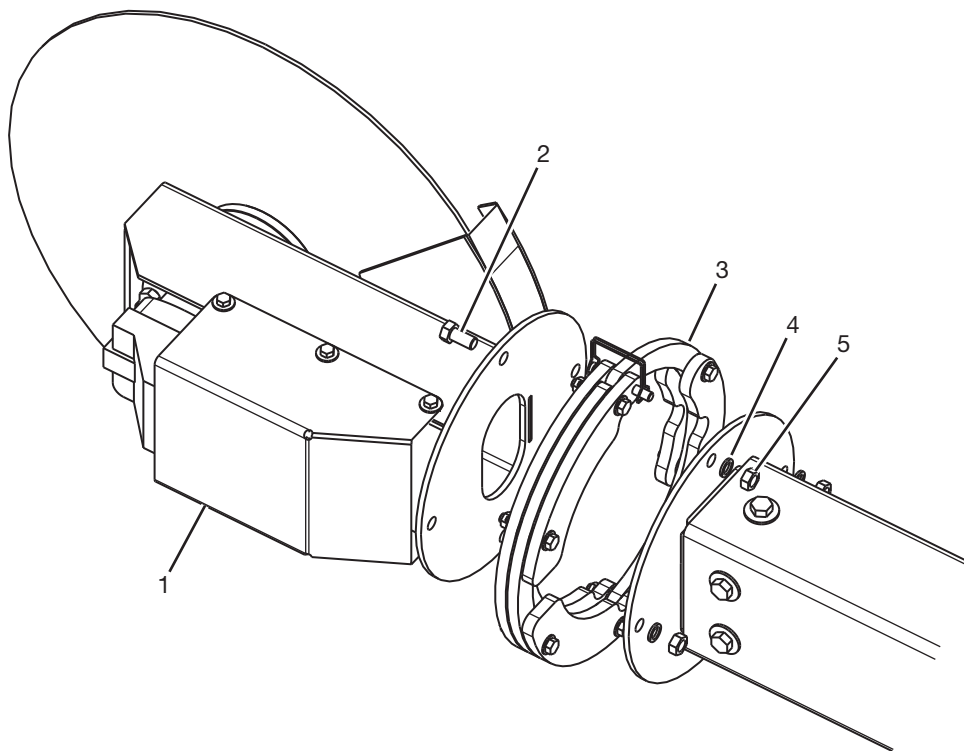

#	QTY.	PART #	DESCRIPTION
1	1	N24594	MOTOR ASSEMBLY (See page 47)
2	4	4011	BOLT, 1/2" X 1" GRADE 5
3	1	N31760	JIG, KWIK TRIM MOTOR MOUNT
4	4	N16472	WASHER, 1/2 NORDLOCK
5	4	4250	NUT, STANDARD 1/2

Parts Identification

Jig, Motor Mount (N31760)

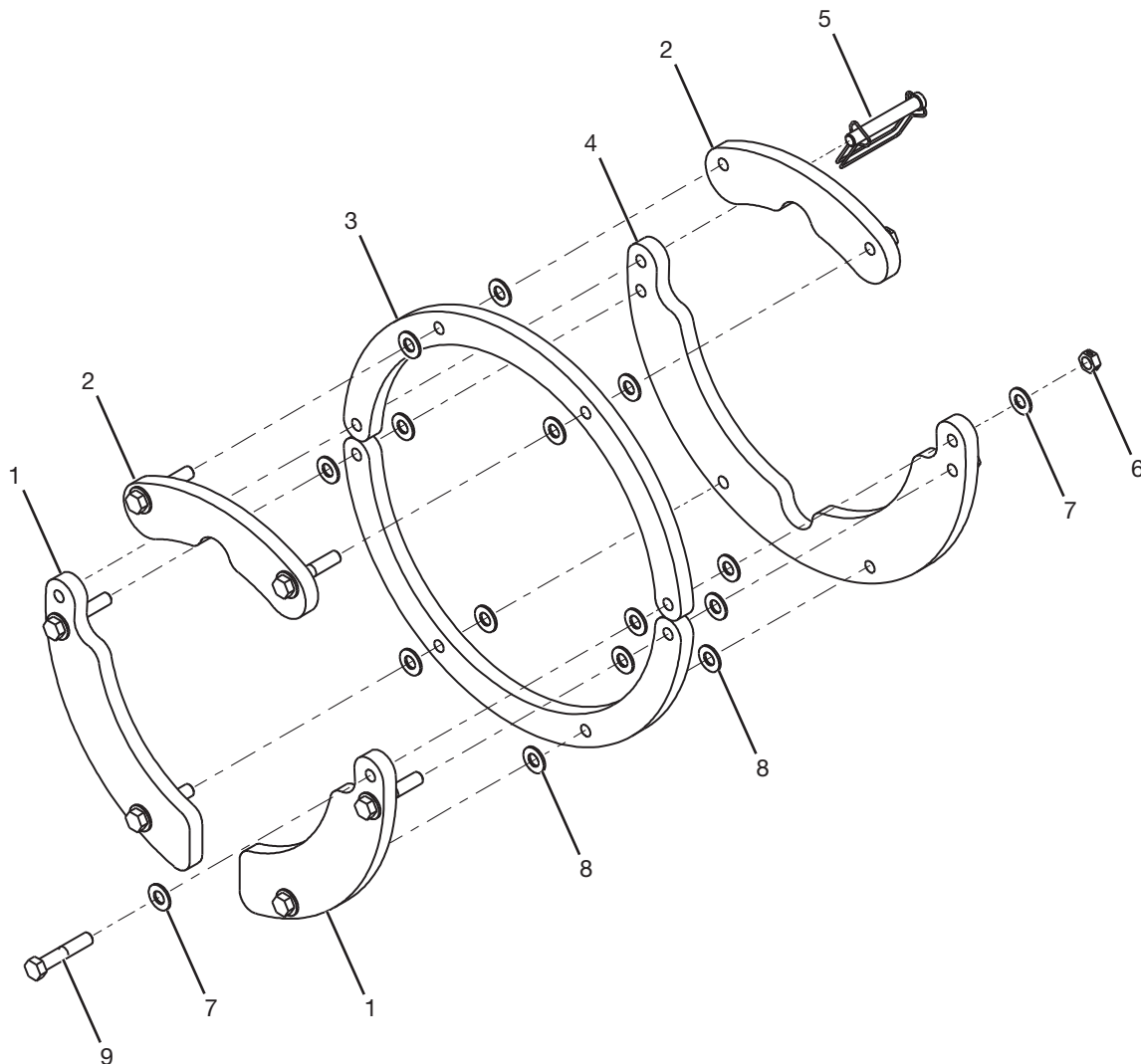

#	QTY.	PART #	DESCRIPTION
1	2	N31774	PLATE, KWIK TRIM JIG BOTTOM L
2	2	N31762	PLATE, KWIK TRIM JIG TOP
3	2	N31761	PLATE, KWIK TRIM JIG INNER
4	1	N31763	PLATE, KWIK TRIM JIG BOTTOM R
5	1	N31221	PIN, 3/8" X 2-1/4" RETAINER
6	7	4052	NUT, LOCK 3/8"
7	14	N31741	WASHER, FLAT 3/8" SAE
8	14	4064	WASHER, FLAT 3/8
9	7	4537	BOLT, 3/8" X 2-1/4" GRADE 5

Parts Identification

Outer Tube Assembly (N38192)

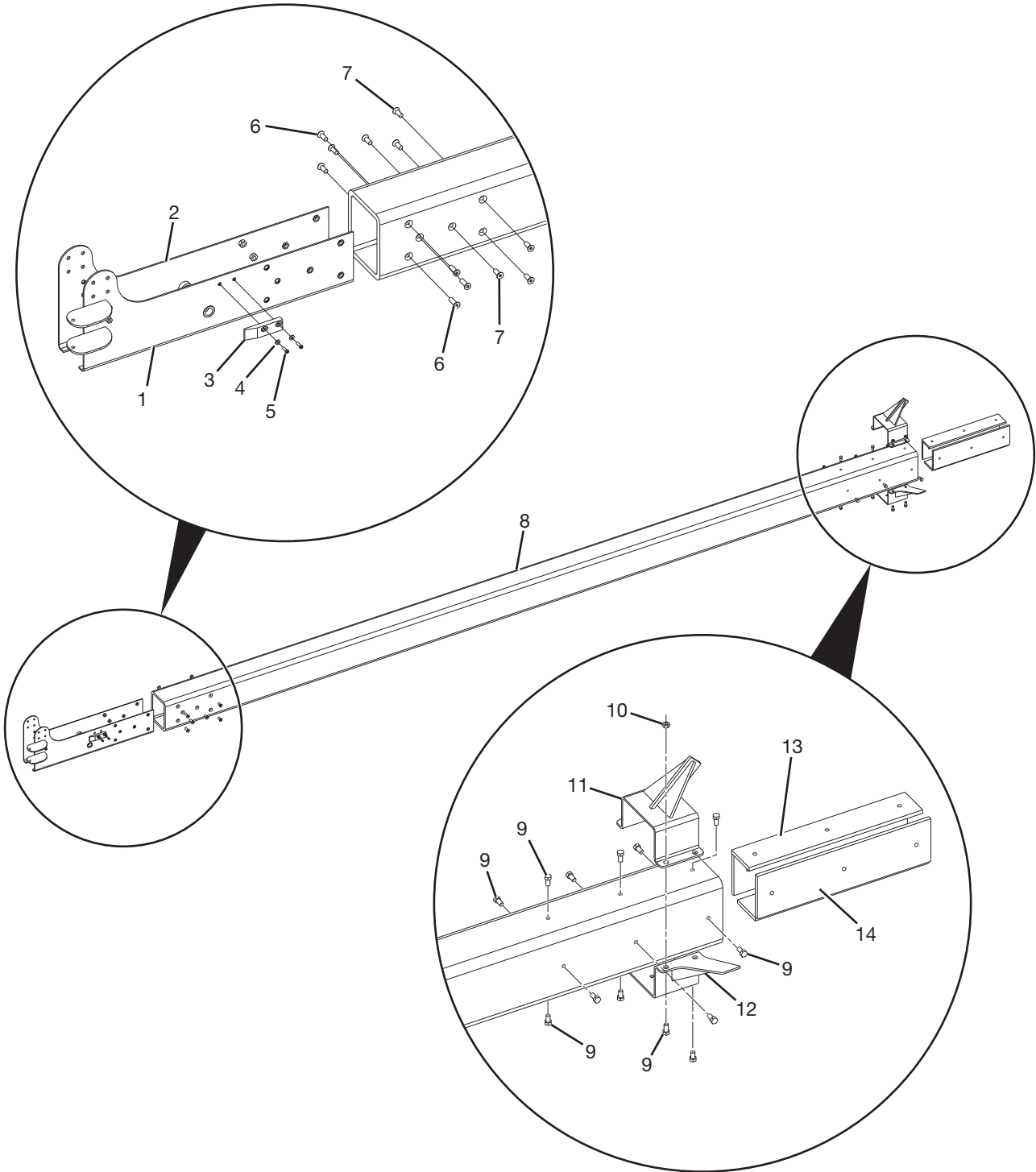

Parts Identification

Outer Tube Assembly (N38192)

#	QTY.	PART #	DESCRIPTION
1	1	N38193	MOUNT, TRUNNION RIGHT
2	1	N24507	MOUNT, TRUNNION LEFT
3	1	N38190	RAMP, SWITCH BOOM
4	2	4460	WASHER, 1/4" SAE FLAT
5	2	N38198	BOLT, BHCS 1/4-20 UNC X 1
6	6	4431	SCREW, FLAT HEAD CAP 1/2" X 1-1/2"
7	6	N24917	SCREW, FHCS 1/2-13 UNC X 1-1/4
8	1	N24475	TUBE, BOOM OUTER
9	16	4011	BOLT, 1/2" X 1" GRADE 5
10	4	4054	NUT, LOCK 1/2" TOP
11	1	N24502	DEFLECTOR, WELDMENT
12	1	N121215	PLATE, CLAMP DEFLECTOR
13	2	N24491	SLIDE, .50" X 4.25" X 24"
14	2	N24492	SLIDE, .50" X 6.25" X 24"

Parts Identification

Tube, w/Slides Inner (N24496)

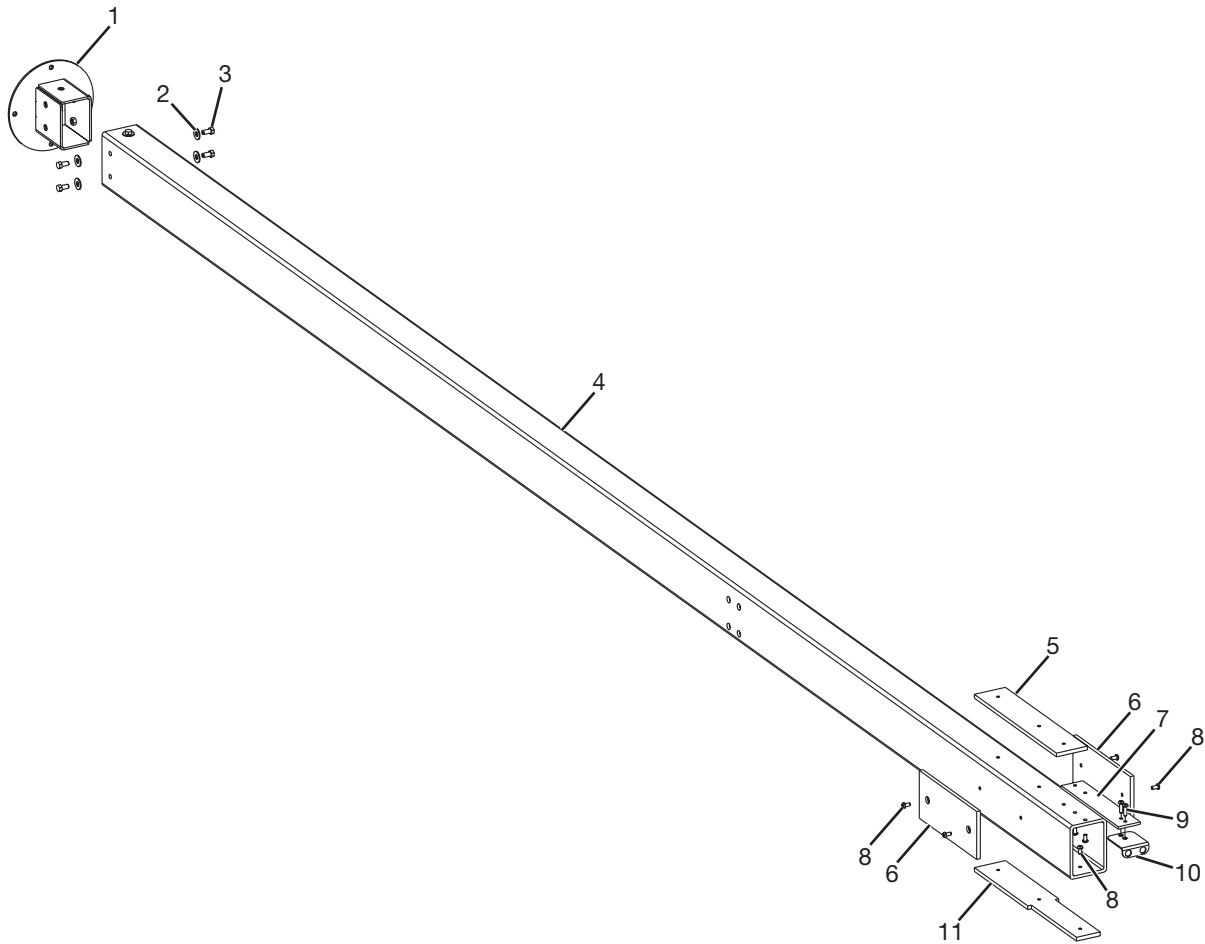

#	QTY.	PART #	DESCRIPTION
1	1	N24573	MOUNT, MOTOR ASSY
2	5	4486	WASHER, 1/2" FLAT
3	5	4011	BOLT, 1/2" x 1" GRADE 5
4	1	N24481	TUBE, BOOM INNER
5	1	N24494	SLIDE, 0.50" x 4.25" x 20"
6	2	N24495	SLIDE, 0.50" x 6.25" x 14"
7	1	N24807	PLATE, EXTENDER BULKHEAD
8	12	N24680	BOLT, 3/8 x 3/4" BHCS
9	2	N24809	BOLT, FHCS 3/8" x 1"
10	1	N24624	MOUNT, WELDMENT BULKHEAD
11	1	N24659	SLIDE, 0.50" x 4.25" x 24"

Clamp, Cradle Top w/Slides (N38185)

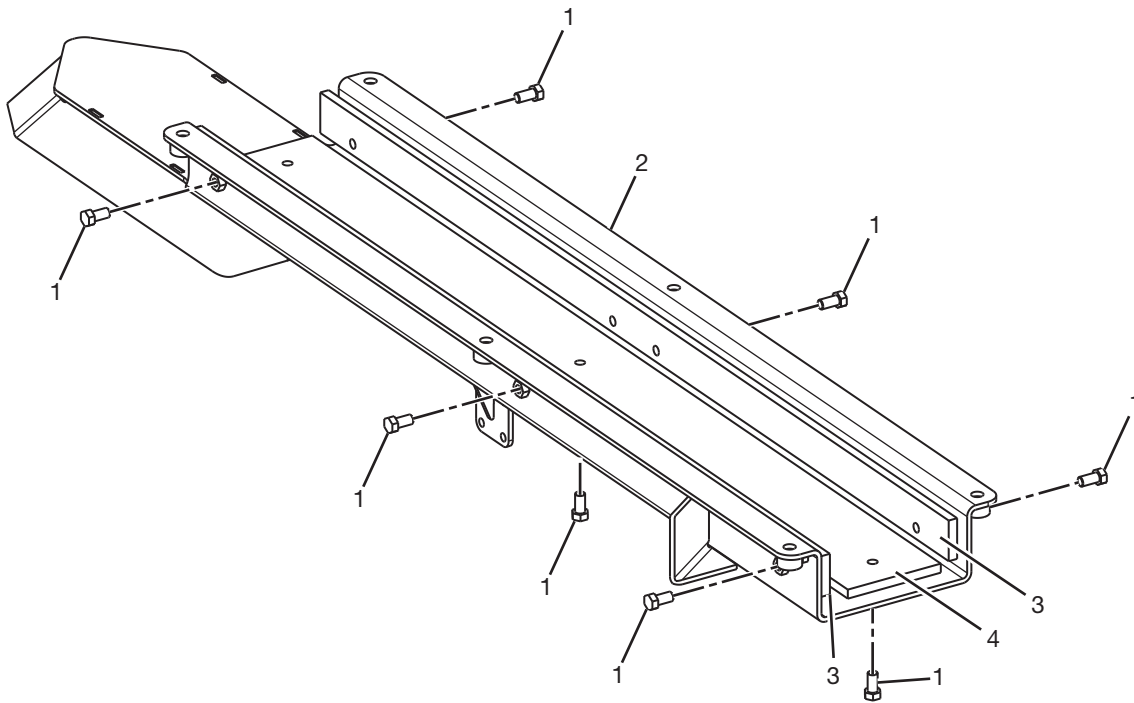

Underside of clamp shown for clarity.

#	QTY.	PART #	DESCRIPTION
1	9	4011	BOLT, 1/2" X 1" GRADE 5
2	1	N38186	CLAMP, BOOM TOP WELDMENT
3	2	N24509	PLATE, SLIDE SIDE
4	1	N24508	PLATE, SLIDE TOP

Parts Identification

Cradle Assembly (N38178)

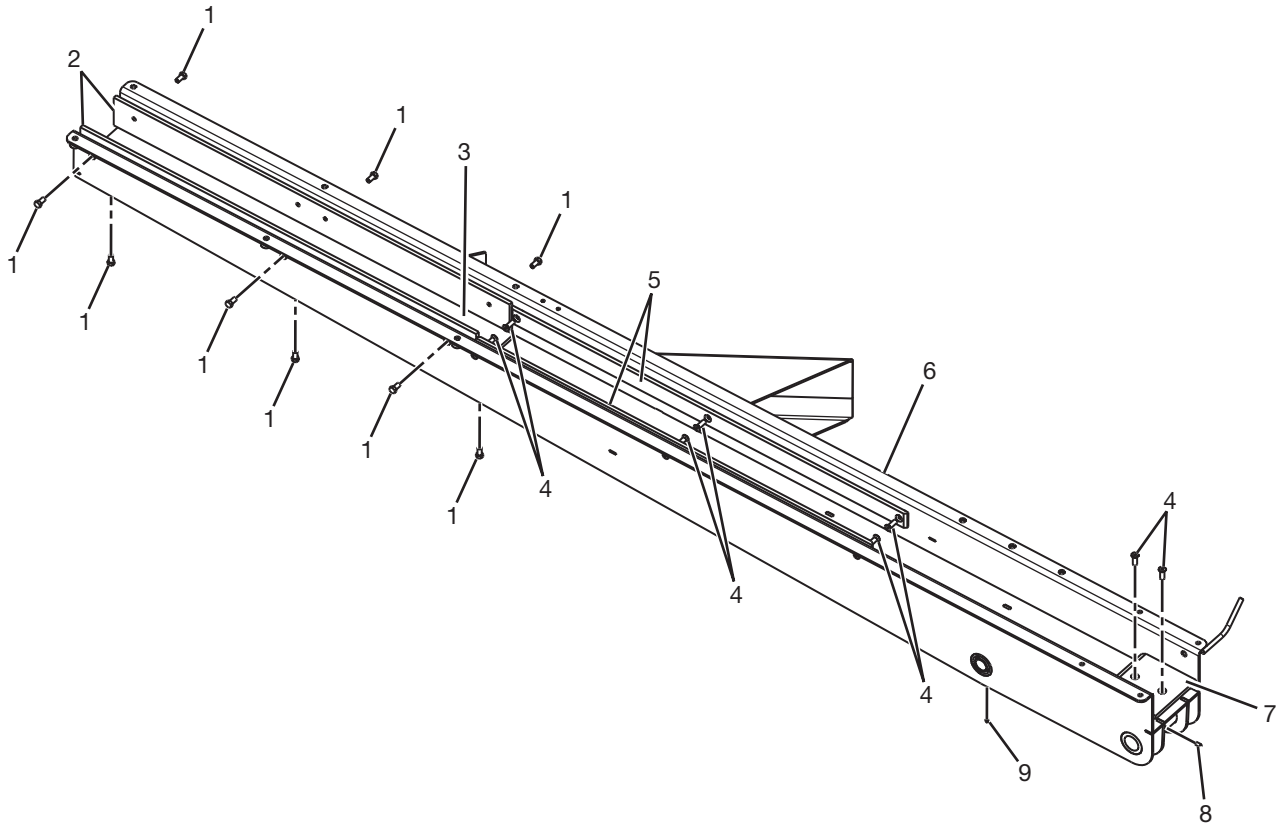

#	QTY.	PART #	DESCRIPTION
1	9	4011	BOLT, 1/2" X 1" GRADE 5
2	2	N24506	SLIDE, CLAMP SIDE
3	1	N24505	SLIDE, BOTTOM TRANSPORT
4	8	4431	SCREW, FLAT HEAD CAP 1/2" X 1-1/2"
5	2	N55297	PLATE, SLIDE SIDE
6	1	N38179	CRADLE, WELDMENT
7	1	N24638	SLIDE, BOTTOM TRANSPORT
8	1	N22210	SCREW, 3/8-16 X 3/4 SCKT HD SET
9	2	N17007	GREASE-ZERK, 1/4" SCREW-IN

Parts Identification

Motor Assembly (N24594)

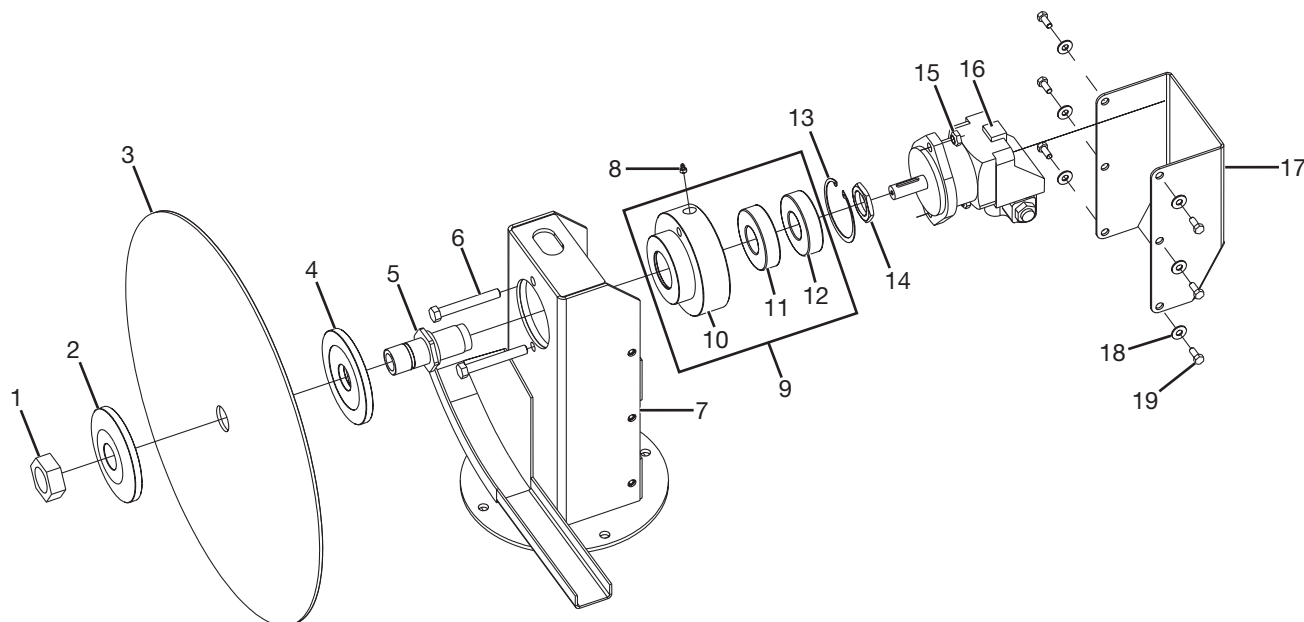

#	QTY.	PART #	DESCRIPTION
1	1	N28024	NUT, JAM 1-1/2 FINE LEFT HAND
2	1	N24653	WASHER, ARBOR
3	1	N24576	BLADE, 24" CARBIDE TIP
4	1	N24652	WASHER, W/2-1/4" HEX
5	1	N24650	SHAFT, 2-1/4 HEX
6	2	4154	BOLT, 1/2" X 3-1/2" GRADE 5
7	1	N24561	MOUNT, MOTOR WELDMENT
8	1	4105	GREASE-ZERK, 1/4" SCREW-IN
9	1	N24578	OHLA, W/BEARINGS
10	1	N24654	HUB, 6# BEARING ASSY
11	1	N24592	BEARING, 40MM ONE SEAL
12	1	N24591	BEARING, 40MM NO SEALS
13	1	N24684	RETAINING RING, 3 1/2"BD X.109
14	1	N24651	NUT, HEX 1-1/2 FINE
15	2	4054	NUT, LOCK 1/2" TOP
16	1	N38121	MOTOR, VOAC 9.8CC (See page 48)
17	1	N24558	PLATE, COVER MOTOR FORMED
18	6	4369	WASHER, 5/16" FLAT
19	6	4412	BOLT, 5/16" X 3/4" GRADE 5

Parts Identification

Motor (N38121)

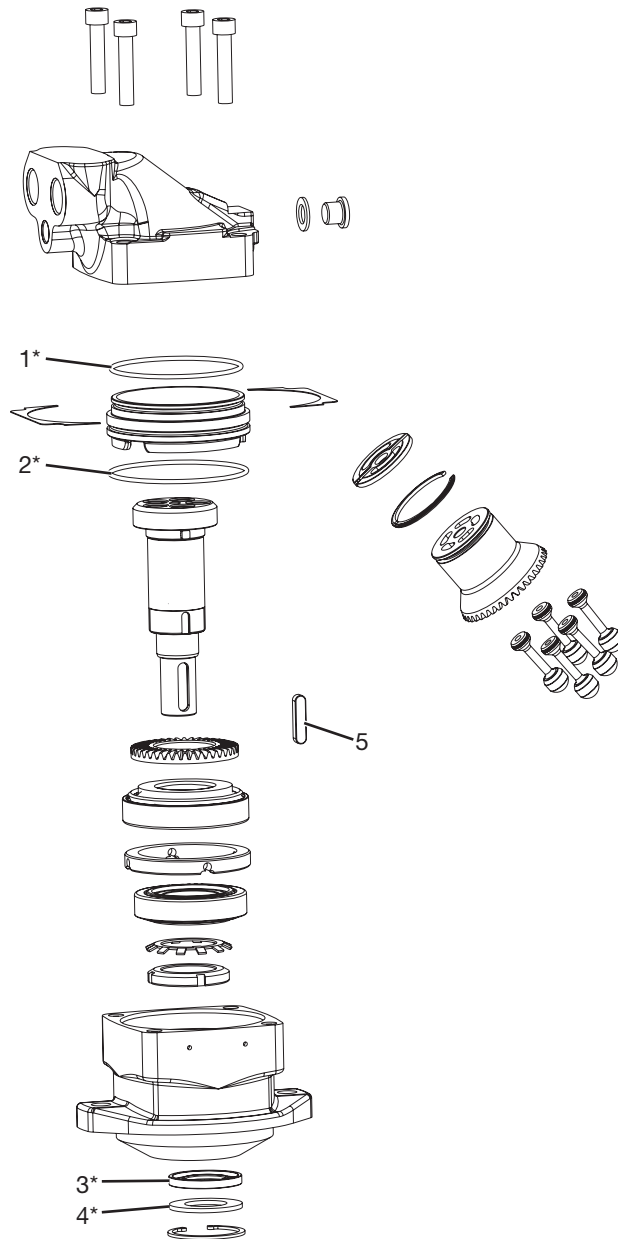

#	QTY.	PART #	DESCRIPTION
*	1	N24866	SEAL KIT (Includes Items 1, 2, 3, and 4)
1	1	-	O-RING
2	1	-	O-RING
3	1	N38460	SHAFT SEAL
4	1	-	SEAL
5	1	N24867	KEY, 6 X 6 X 35

Hydraulic Hose Reel

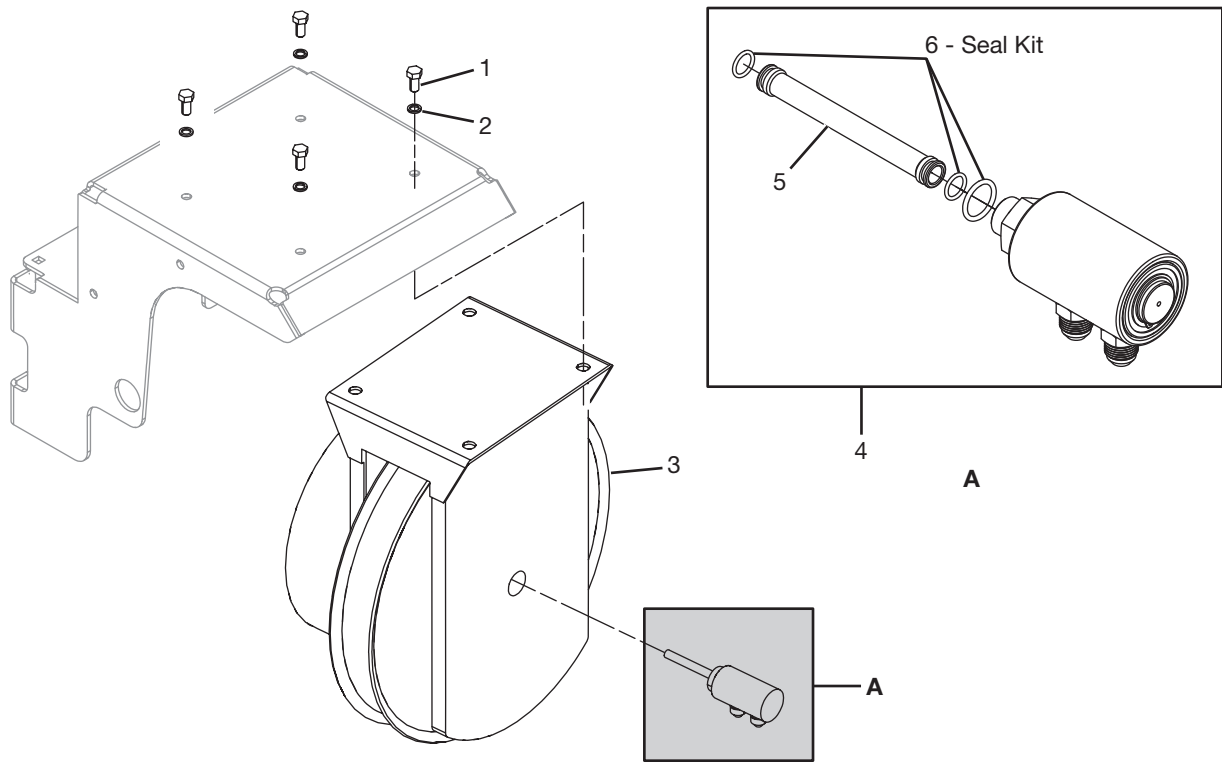

#	QTY.	PART #	DESCRIPTION
1	4	4011	BOLT, BOLT, 1/2" X 1" GR 5
2	4	N16472	WASHER, NORD-LOCK 1/2"
3	1	N38310	HOSE REEL, WITH WELD NUTS
4	1	205014	SWIVEL, JOINT COMPLETE ASSY
5	1	205015	TUBE CENTER
6	1	205016	KIT, SEAL SWIVEL VITON

Parts Identification

Hydraulics

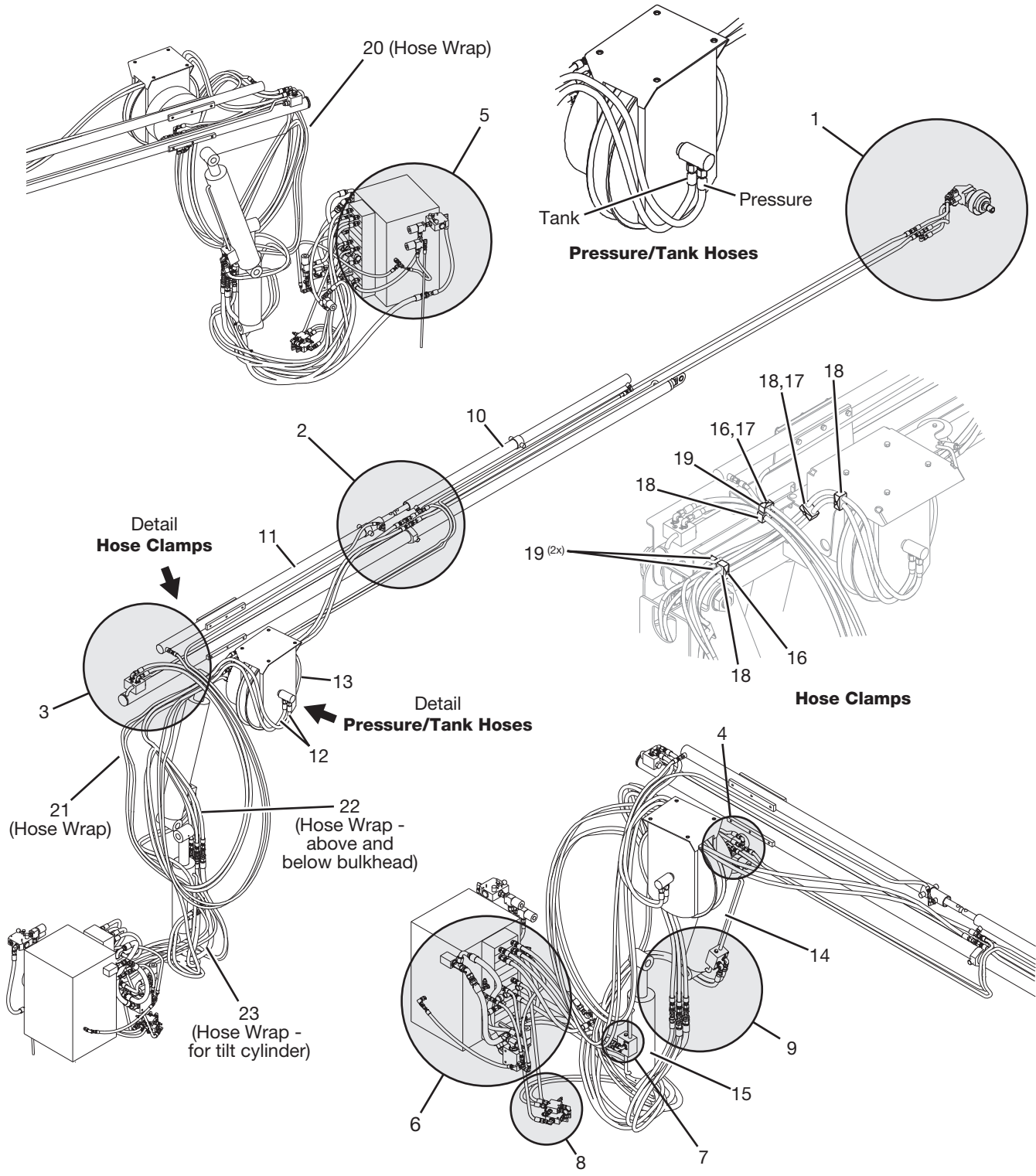

Hydraulics

#	QTY.	PART #	DESCRIPTION
1			(See page 52; Detail A)
2			(See page 52; Detail B)
3			(See page 52; Detail C)
4			(See page 52; Detail D)
5			(See page 54; Detail E)
6			(See page 56; Detail F)
7			(See page 58; Detail G)
8			(See page 58; Detail H)
9			(See page 58; Detail I)
10	1	N24639	CYLINDER, 2" BORE 72" STROKE
11	1	N24629	CYLINDER, 2" BORE 72" STROKE
12	2	N38381	HOSE, 1/2 X 108 LG-8FJIC-10FJC
13	1	N38309	REEL, HOSE HOLES ENLARGED (See page 49)
14	1	N28733	CYLINDER, 5" X 24" CINTERBLNCE
15	1	N28732	CYLINDER, 5" X 12" CINTERBLNCE
16	2	200654	BOLT, 5/16" X 3-3/4" GRADE 5
17	2	4051	NUT, LOCK 5/16
18	4	N13383	CLAMP, DBL. 1/2" SUPP. HOSE
19	3	N21365	CLAMP, 3/8" DOUBLE HOSE
20	1	N129313	HOSE, SLEEVE 2-1/2 X 62
21	1	N129323	SLEEVE, HOSE 2-1/2 X 154
22	2	N129321	SLEEVE, HOSE, 3 X 38
23	1	N129309	SLEEVE, HOSE 2-1/2 X 45

Parts Identification

Hydraulics (Cont'd)

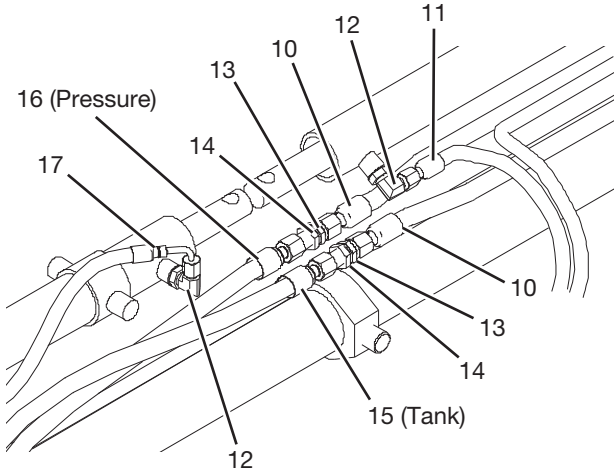

DETAIL B

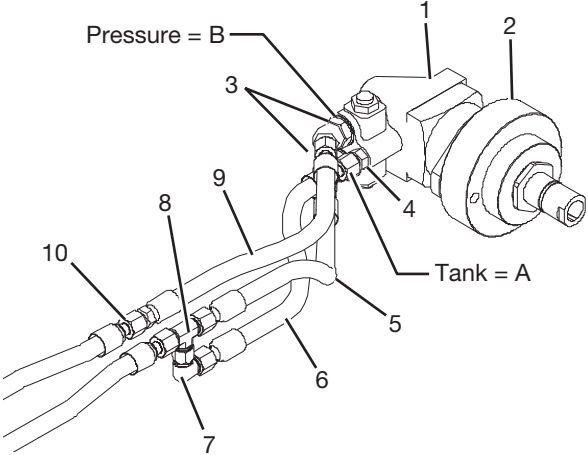

DETAIL A

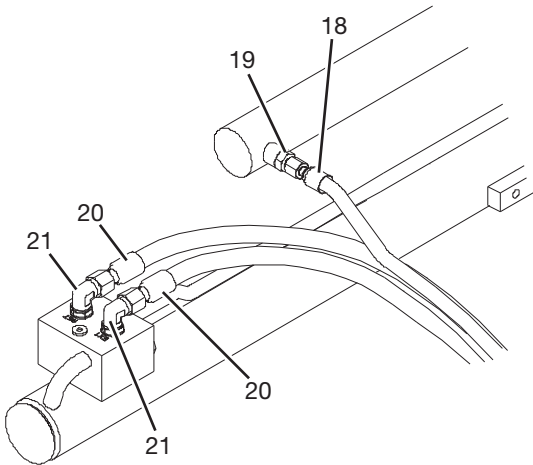

DETAIL C

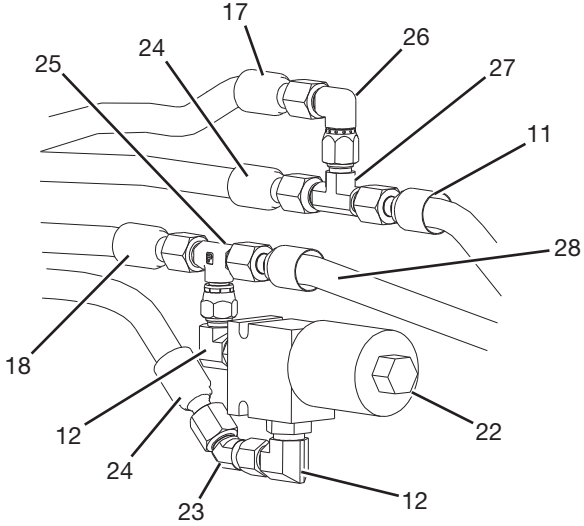

DETAIL D

Parts Identification

Hydraulics (Cont'd)

#	QTY.	PART #	DESCRIPTION
1	1	N38121	MOTOR, VOAC 9.8CC
2	1	N24578	OHLA, W/BEARINGS
3	2	N26332	ELBOW, 45 DEG - 8MJIC - 12MOR
4	1	N24647	ADAPTER, -8MJIC -6MOR
5	2	N24825	HOSE, 1/2" 15" -8FJIC -8FJIC
6	1	N24826	HOSE, 3/8" X 15" -8FJIC -8FJIC
7	1	N24827	ELBOW, 90 DEG - 8FJC - 8MJC
8	1	N17001	TEE, 8MJIC-8MJIC-8MJIC
9	1	N34710	HOSE, 1/2" 17" -8FJIC -8MJIC
10	2	N24681	HOSE, TWIN LINE -8FJIC -8FJIC
11	2	N38378	HOSE, 3/8 X 92 LG -6FJX-6FJX
12	4	N20037	ELBOW, 90 DEG - 6MJIC - 8MOR
13	6	N24621	ADAPTER, BULKHEAD -8MJIC -8MJIC
14	2	N26387	NUT, JAM; -08 BULKHEAD
15	2	N28891	HOSE, 1/2-8FJIC -10FJIC X 270"
16	2	N28892	HOSE, 1/2 8FJIC -10FJIC X 286"
17	1	N38379	HOSE, 3/8 X 268 LG-6FJX-6FJX90
18	1	N24841	HOSE, 3/8" X 192" -6FJIC -FJIC
19	2	N17022	ADAPTER, 6MJIC - 8MOR
20	2	N38380	HOSE, 1/2 X 209 LG-8FJIC-FJIC
21	2	N11952	ELBOW, 90 DEG - 08MJIC - 08MOR
22	1	N24832	VALVE, SOLENOID 12VDC N.C.
23	1	N28837	ELBOW, 45 DEG - 6MJIC -6FJIC
24	2	N38377	HOSE, 3/8 X 182 LG -6FJX-6FJX
25	1	N23832	TEE, 6MJIC - 6MJIC - 6FJX SWIVEL
26	5	N29078	ELBOW, 90 DEG - 6MJIC - 6FJIC
27	1	N24773	TEE, 6MJIC-6MJIC-6MJIC
28	1	N38419	HOSE, 3/8" X 151" -6FJIC -6FJC

Parts Identification

Hydraulics (Cont'd)

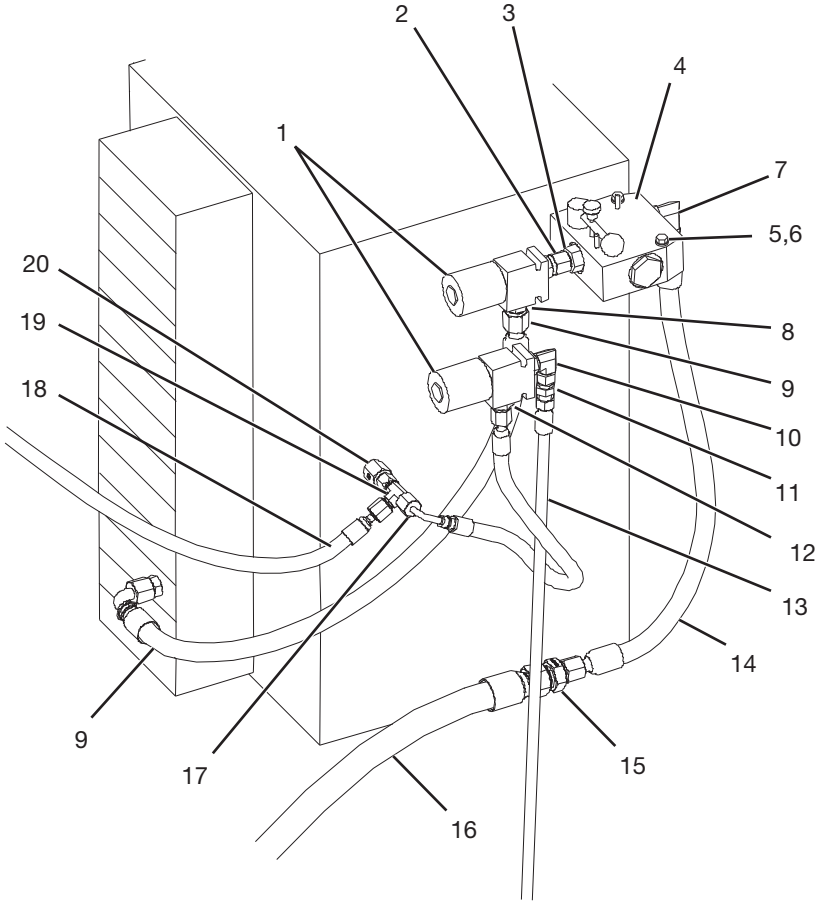

DETAIL E

Parts Identification

Hydraulics (Cont'd)

#	QTY.	PART #	DESCRIPTION
1	3	205010	VALVE, SOLENOID 12VDC N.O.
2	1	N24835	ADAPTER, 8MOR - 8FJIC
3	1	N12444	ADAPTER, 8MJIC - 10MOR
4	1	N28387	VALVE, FLOW CONTROL
5	2	4003	BOLT, 1/4 X 2-1/2 GRD 5
6	2	N16468	WASHER, NORDLOCK 1/4
7	1	N16173	ELBOW, 90 DEG - 8-MJC - 10MOR
8	1	N20228	ADAPTER, 8MJC - 8MOR
9	1	N38372	HOSE, 1/2 X 24 LG -8FJX-8FJX90
10	1	N20037	ELBOW, 90 DEG - 6MJIC - 8MOR
11	2	N34164	ADAPTER, 6FJIC - 4MBSPP
12	1	N17022	ADAPTER, 6MJIC - 8MOR
13	1	PA7	HOSE, TAKEUCHI PA7
14	2	N38375	HOSE, 1/2 X 24 LG -8FJX-8FJX
15	1	N38339	ADAPTER, 8MJC - 12MBSPP
16	1	AUXL	HOSE, TAKEUCHI AUXL
17	1	N38370	HOSE, 1/4 X 11 LG -6FJX-6FJX90
18	1	N38369	HOSE, 1/4 X 37 LG -6FJX-6FJX90
19	2	N37279	TEE, -6MJIC-6FJIC-6MJIC
20	1	N34326	ADAPTER, -6MJIC -4FBSPP

Parts Identification

Hydraulics (Cont'd)

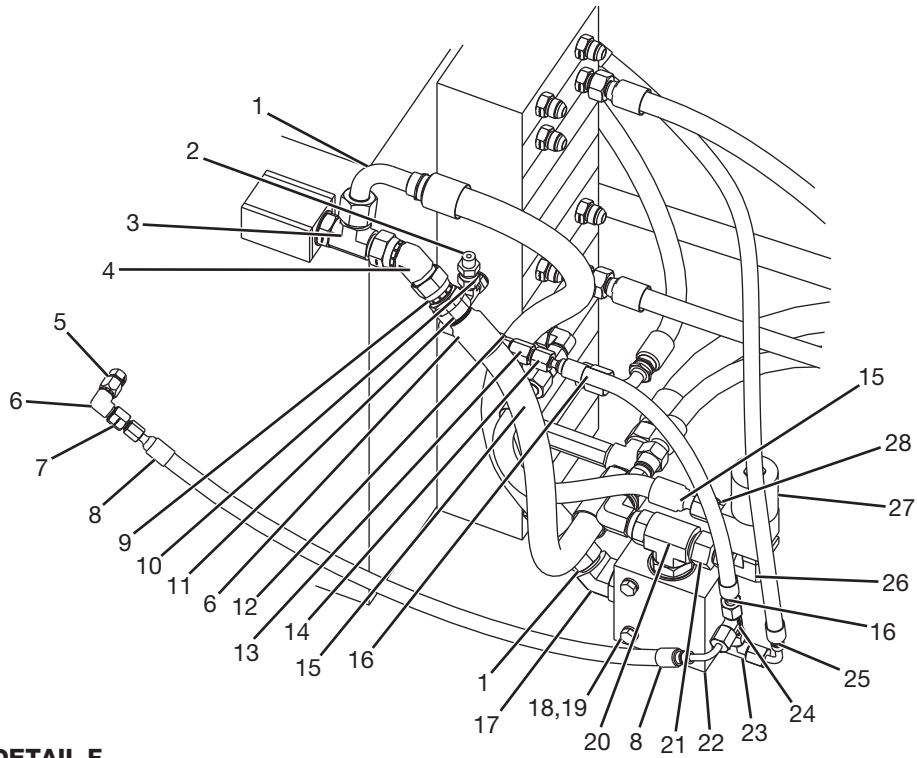

DETAIL F
(two views)

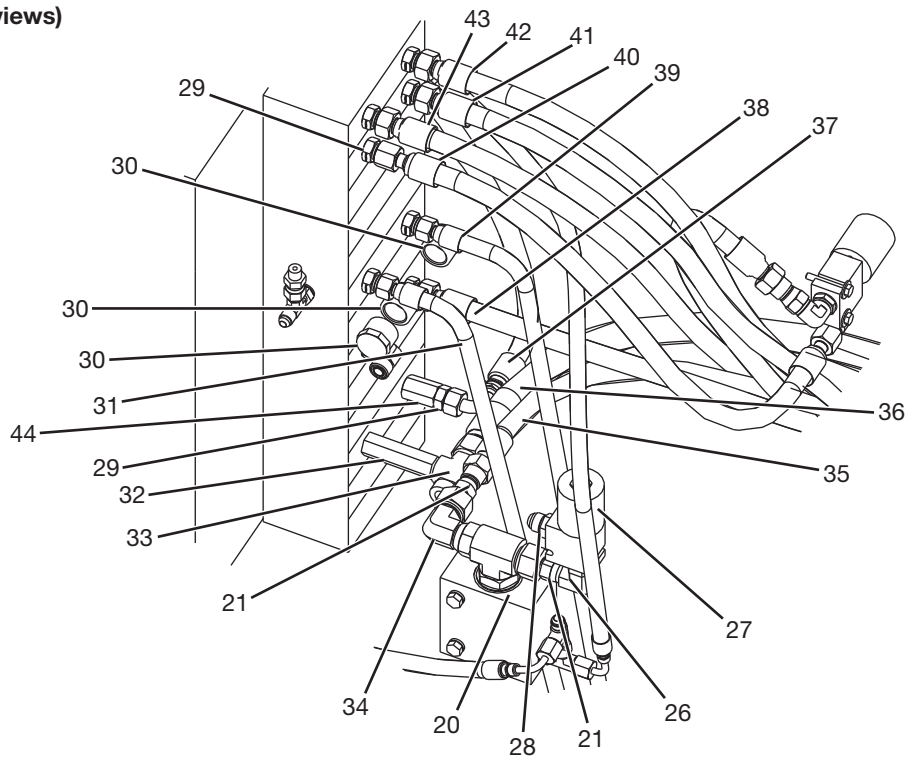

Parts Identification

Hydraulics (Cont'd)

#	QTY.	PART #	DESCRIPTION
1	1	N38376	HOSE, 3/4 X 27LG-12FJX-12FJX90
2	2	N34164	ADAPTER, 6FJIC - 4MBSPP
3	1	N38344	TEE, -12MJIC -12MJIC -12MORBSP
4	1	N25881	ELBOW, 45 DEG - 12MJIC - 12FJX
5	1	N28846	ADAPTER, -6MJIC -4MBSPP
6	5	N29078	ELBOW, 90 DEG - 6MJIC - 6FJIC
7	1	N38420	ADAPTER, 6FJIC -4MJIC .020 OR
8	1	N38368	HOSE, 1/4 X 28 LG -4FJX-6FJX90
9	1	N38313	ADAPTER, -12FJIC -12BSPP
10	1	N34163	TEE, RUN 6MJIC -6MJIC -4MBSPP
11	1	B6	HOSE, TAKEUCHI B6
12	1	N14117	ADAPTER, 6FJIC SW - 4FP
13	1	N38346	VALVE, CHECK 1/4NPTF MALE
14	1	N28766	ADAPTER, 6MJIC - 4FP
15	1	N38374	HOSE, 1/2 X 13 LG -8FJX-8FJX
16	1	N38371	HOSE, 1/4 X 18 LG -6FJX-6FJX
17	1	N16174	ELBOW, 45 DEG 12MJIC - 16MOR
18	2	4007	BOLT, 3/8" X 3" GRADE 5
19	2	N16470	WASHER, 3/8 NORDLOCK
20	1	N38343	TEE, -12MJIC -12MJIC -16MORB
21	2	N11948	ADAPTER, 12FJIC - 8MJIC
22	1	N34170	VALVE, PILOT TO OPEN
23	1	N16169	TEE, 6MJIC-6MOR-6MJIC
24	2	N37279	TEE, -6MJIC-6FJIC-6MJIC
25	1	N38369	HOSE, 1/4 X 37 LG -6FJX-6FJX90
26	1	N20548	ELBOW, 90 DEG - 8MOR - 8FJIC (6809-8-8)
27	4	205010	VALVE, SOLENOID 12VDC N.O.
28	2	N20228	ADAPTER, 8MJC - 8MOR
29	2	N38280	ADAPTER, -8MJIC -8MBSPP
30	3	N38276	CAP, SWIVEL -12BSPP
31	1	BSWH	HOSE, TAKEUCHI BSWH
32	1	N132116	LONG -8MBSPP-8FBSPP
33	1	N38349	TEE, -12MBSPP -12MBSPP -8MBSPP
34	1	N21333	ELBOW, 90 DEG-12MJIC-12FJIC, 6500-12-12
35	2	ARMR	HOSE, TAKEUCHI ARMR
36	1	AUXR	HOSE, TAKEUCHI AUXR
37	1	N38372	HOSE, 1/2 X 24 LG -8FJX-8FJX90
38	1	ARMH	HOSE, TAKEUCHI ARMH
39	1	BSWR	HOSE, TAKEUCHI BSWR
40	1	N38373	HOSE, 1/2 X 19 LG -8FJX-8FJX
41	1	BOOR	HOSE, TAKEUCHI BOOR
42	1	BUCR	HOSE, TAKEUCHI BUCR
43	1	BUCH	HOSE, TAKEUCHI BUCH
44	1	N132118	ADAPTER, EXTEND MED -8MBSPP-8FBSPP

Parts Identification

Hydraulics (Cont'd)

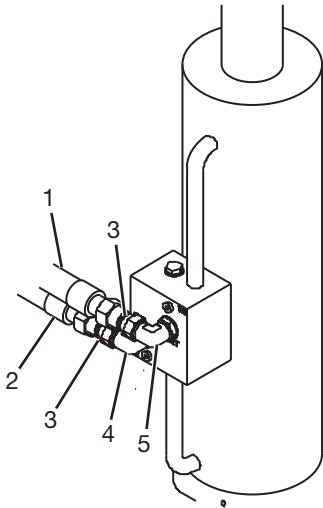

DETAIL G

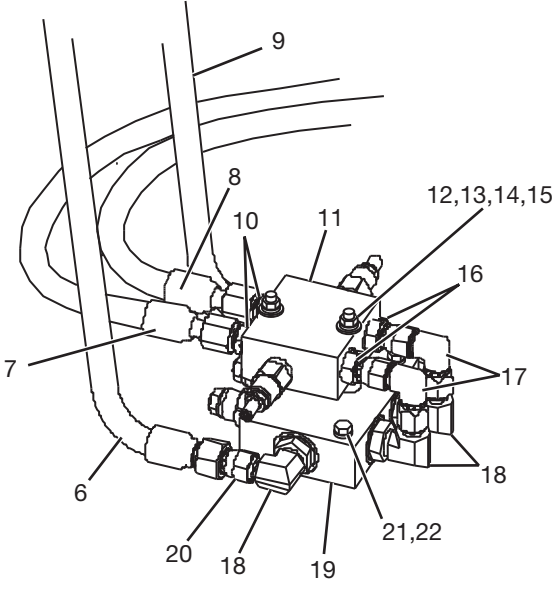

DETAIL H

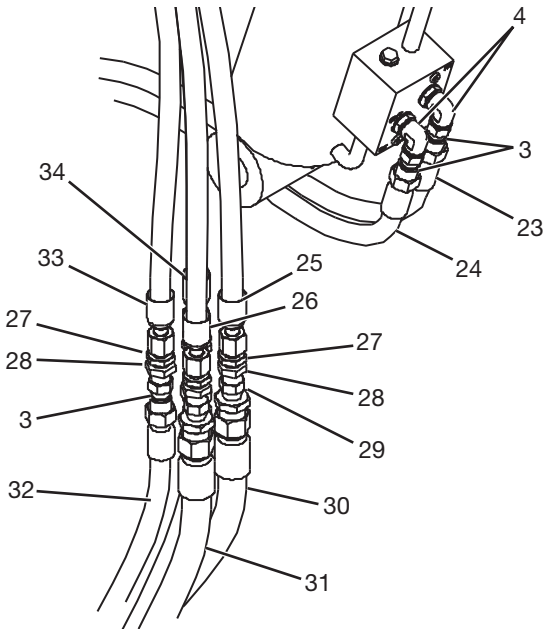

DETAIL I

Parts Identification

Hydraulics (Cont'd)

#	QTY.	PART #	DESCRIPTION
1	1	BUCR	HOSE, TAKEUCHI BUCR
2	1	BUCH	HOSE, TAKEUCHI BUCH
3	6	N24648	ADAPTER, 8FJIC - 8MBSPP
4	3	N11952	ELBOW, 90 DEG - 08MJIC - 08MOR
5	1	207765	ELBOW, 90 DEG -08MJIC -08MOR .062 ORIFICE
6	1	BSWH	HOSE, TAKEUCHI BSWH
7	1	N157596	HOSE, 3/8 X 182 LG -6FJX-6FJX
8	1	N38377	HOSE, 3/8 X 182 LG -6FJX-6FJX
9	1	BSWR	HOSE, TAKEUCHI BSWR
10	6	N24821	ADAPTER, 6MOR - 6MJIC
11	1	N24645	VALVE, CROSSPORT RELIEF
12	2	4002	BOLT, 1/4 X 2-1/4
13	2	3183	WASHER, FLAT 1/4
14	2	4231	WASHER, LOCK 1/4
15	2	4230	NUT, STANDARD 1/4
16	2	N28832	ADAPTER, 6MOR - 6FJIC
17	5	N29078	ELBOW, 90 DEG - 6MJIC - 6FJIC
18	4	N20037	ELBOW, 90 DEG - 6MJIC - 8MOR
19	1	N24644	VALVE, COUNTERBALANCE
20	2	N28848	ADAPTER, 6MBSPP - 6FJIC
21	2	4227	BOLT, 5/16 X 2
22	2	N16469	WASHER, NORD-LOCK 5/16
23	1	BOOR	HOSE, TAKEUCHI BOOR
24	1	BOOH	HOSE, TAKEUCHI BOOH
25	1	N157600	HOSE, 1/2 X 108 LG-8FJIC-10FJC
26	1	N38381	HOSE, 1/2 X 108 LG-8FJIC-10FJC
27	4	N24621	ADAPTER, BULKHEAD -8MJIC -8MJIC
28	4	N26387	NUT, JAM; -08 BULKHEAD
29	2	N38345	ADAPTER, 12MBSPP - 8FJIC
30	1	AUXR	HOSE, TAKEUCHI AUXR
31	1	AUXL	HOSE, TAKEUCHI AUXL
32	1	ARMR	HOSE, TAKEUCHI ARMR
33	1	N157598	HOSE, 1/2 X 209 LG-8FJIC-8FJC
34	1	N38380	HOSE, 1/2 X 209 LG-8FJIC-8FJC

Parts Identification

Hydraulics, Winch

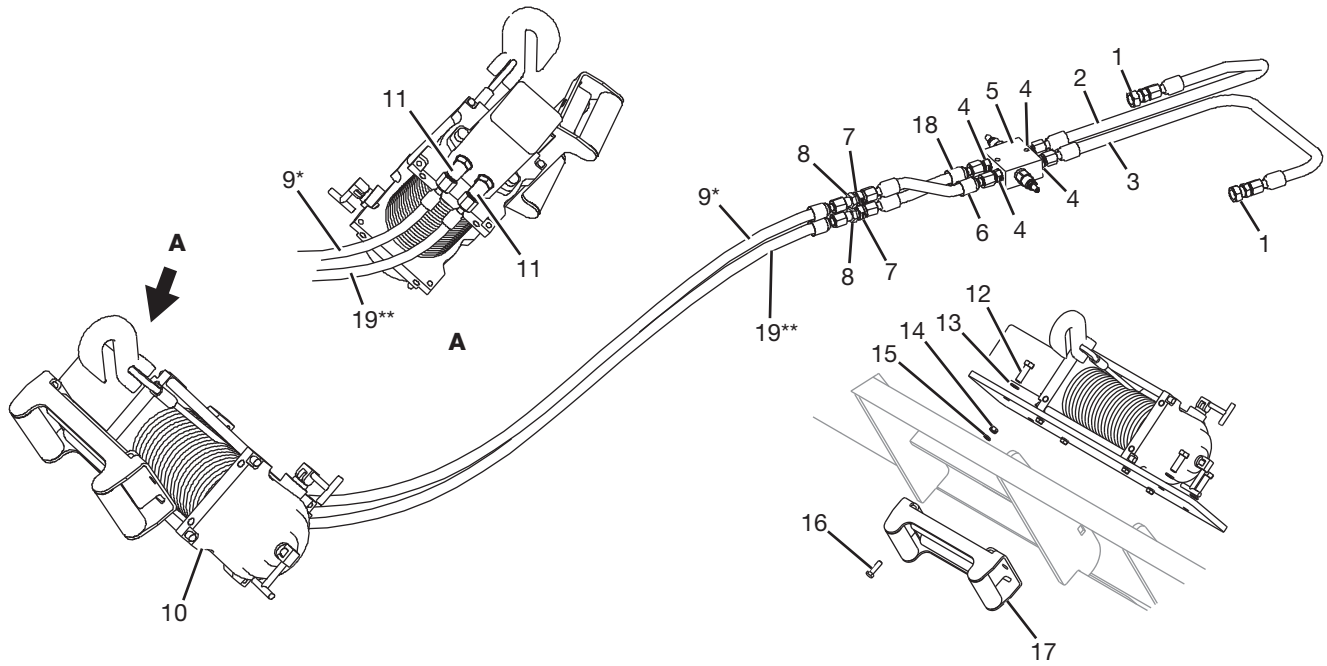

Parts Identification

Hydraulics, Winch

#	QTY.	PART #	DESCRIPTION
1	2	N24777	ADAPTER, -6MJIC -6FBSPP
2	1	N38365	HOSE, 3/8 X 20 LONG -6FJX-6FJX
3	1	N38366	HOSE, 3/8 X 29 LONG -6FJX-6FJX
4	4	N24821	ADAPTER, 6MOR - 6MJIC
5	1	N24645	VALVE, CROSSPORT RELIEF
6	1	N38364	HOSE, 3/8 X 19 LONG -6FJX-6FJX
7	2	N24780	NUT, LOCK BULKHEAD -6
8	2	N24775	ADAPTER, BULKHEAD - 6MJIC-6MJIC
9	1	N38367	HOSE, 3/8 X 48 LONG -6FJX-8FJX
10	1	N28190	WINCH
11	2	N21381	ELBOW, 45 DEG - 8MJC - 10MOR
12	4	4466	BOLT, 1/2" X 1-1/2" GRADE 8
13	4	N16472	WASHER, 1/2 NORDLOCK
14	2	4052	NUT, LOCK 3/8"
15	2	N16470	WASHER, 3/8 NORDLOCK
16	2	4416	BOLT, 3/8" X 1-1/4" GRADE 5
17	1	205000	FAIRLEAD
	1	N34766	CABLE, 3/8" X 100' (Extra cable, not shown)
18	1	N157590	HOSE, 3/8 X 19 LONG -6FJX-6FJX
19	1	N157594	HOSE, 3/8 X 48 LONG -6FJX-8FJX

Parts Identification

Hydraulic Schematic - Lift, Tilt, Transport Cylinders

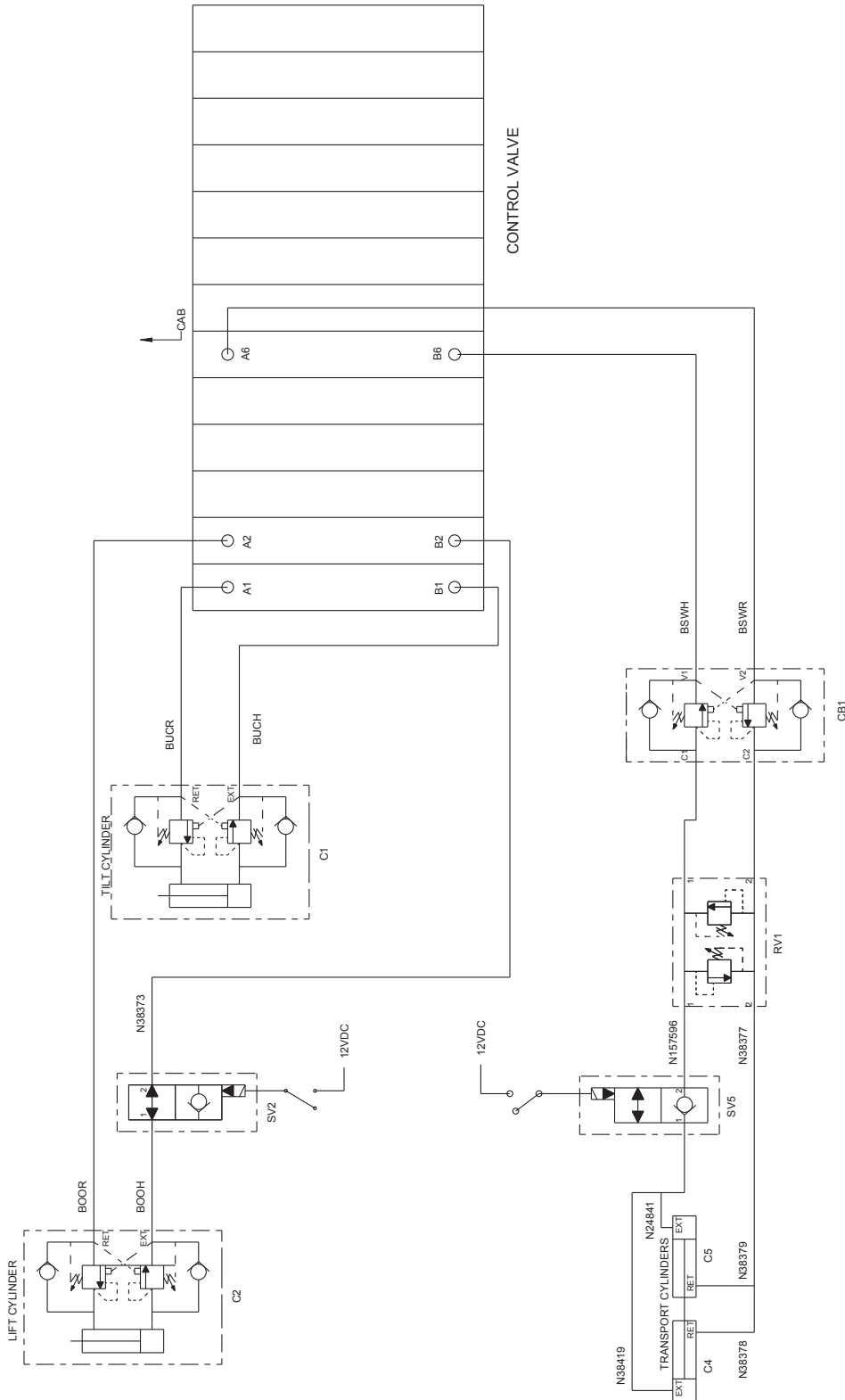

Hydraulic Schematic - Boom and Saw

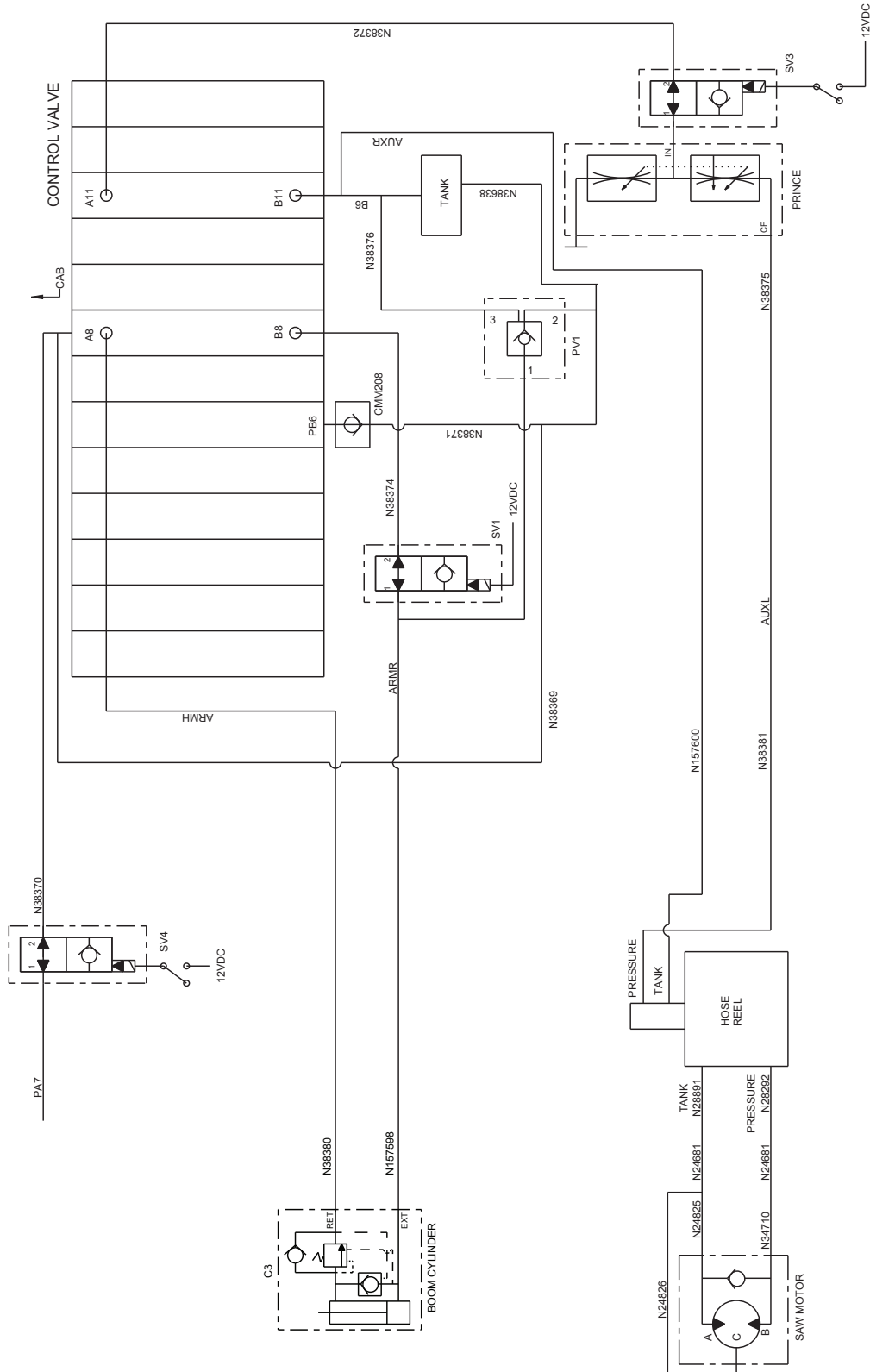

Parts Identification

Hydraulic Schematic, Winch

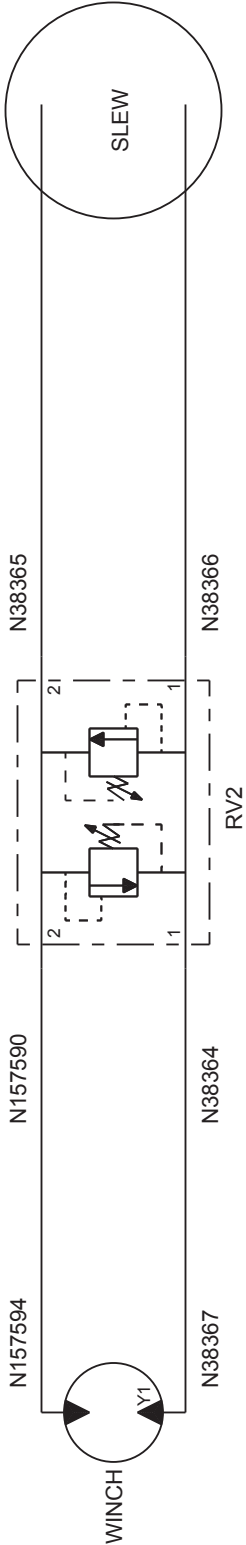

This page intentionally left blank.

Parts Identification

Windows; Front, Top and Left Side

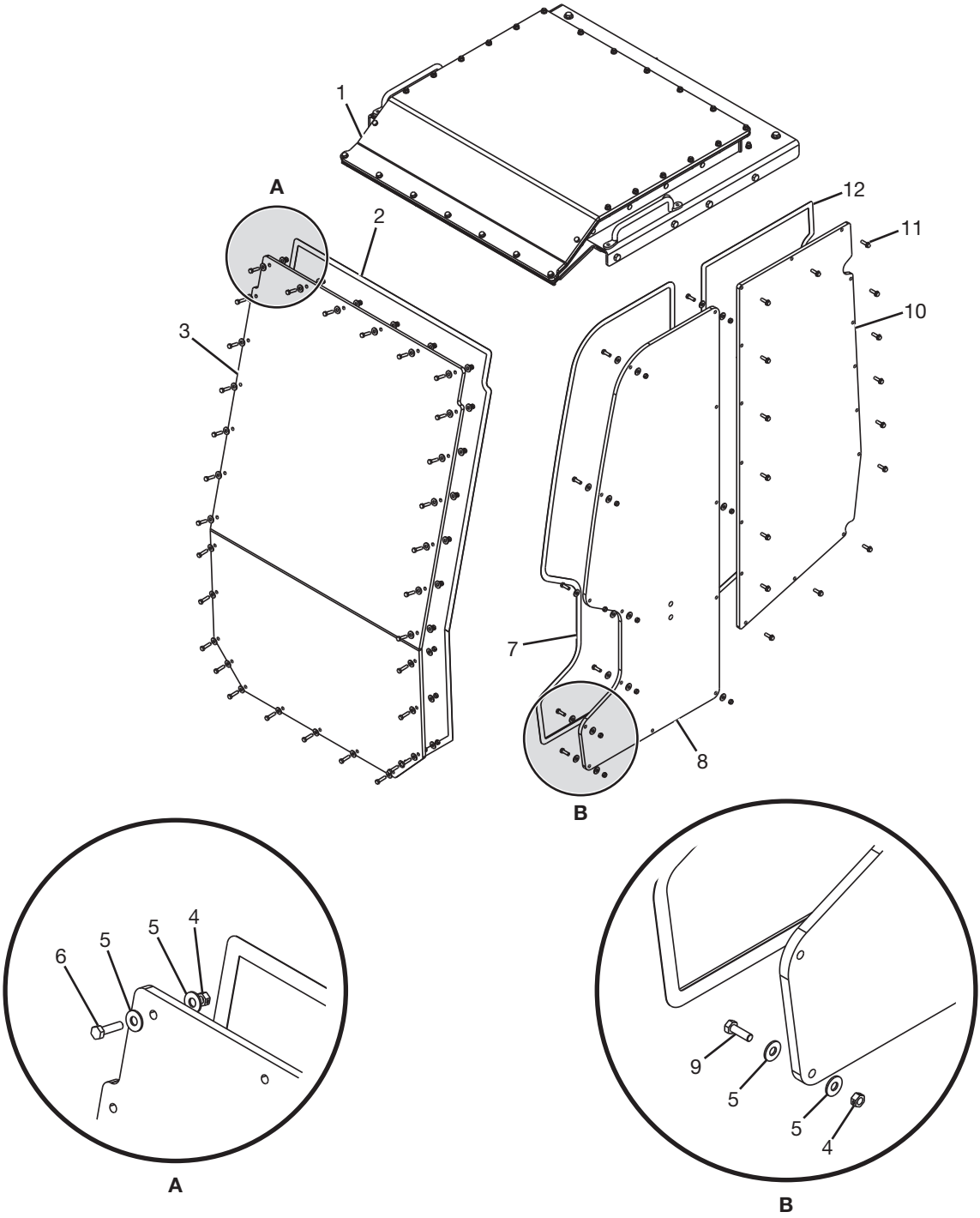

Windows; Front, Top, and Left Side

#	QTY.	PART #	DESCRIPTION
1	1	N129683	TOP, ASSY TB260 (See page 70)
2	1	N38327	FRONT, SEAL RUBBER 1/4
3	1	N129520	PANEL, FRONT KT TB260
4	52	4051	NUT, LOCK 5/16"
5	104	4369	WASHER, 5/16" FLAT
6	31	1141	BOLT, 5/16" X 1-1/4" GR 5 FULL THRD
7	1	N38326	DOOR, SEAL RUBBER 1/4
8	1	N38050	DOOR
9	13	4203	BOLT, 5/16" X 1" GRADE 5
10	1	N38049	PANEL, POLY KWIK TRIM
11	16	N28237	SCREW, 5/16 X 1 SELF TAPPING
12	1	N38325	SIDE, SEAL RUBBER 1/4

Parts Identification

Windows; Rear and Right Side

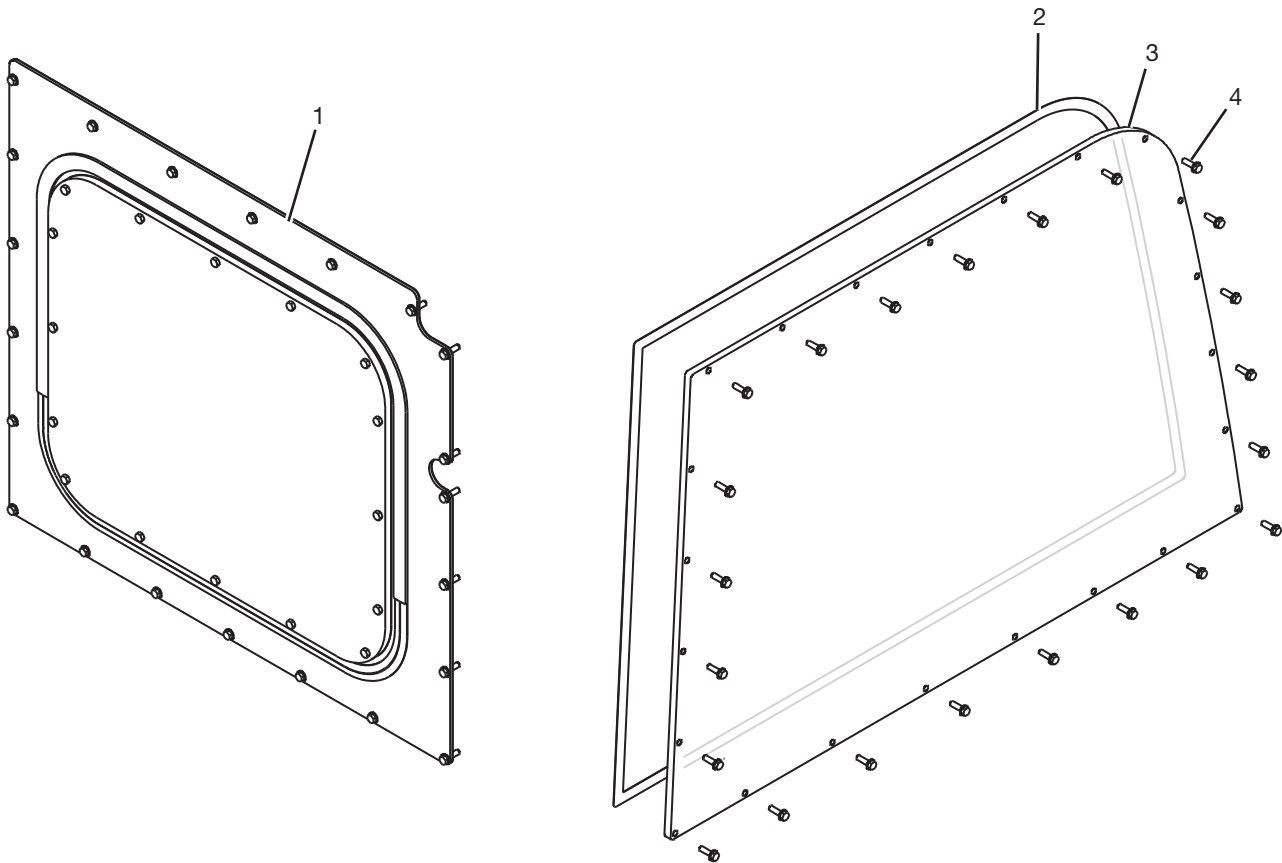

#	QTY.	PART #	DESCRIPTION
1	1	N105428	WINDOW, ESCAPE REAR (See page 69)
2	1	N38321	ESCAPE, SEAL RUBBER 1/4
3	1	N105416	WINDOW, RIGHT
4	23	N28237	SCREW, 5/16 X 1 SELF TAPPING

Window, Escape (N105428)

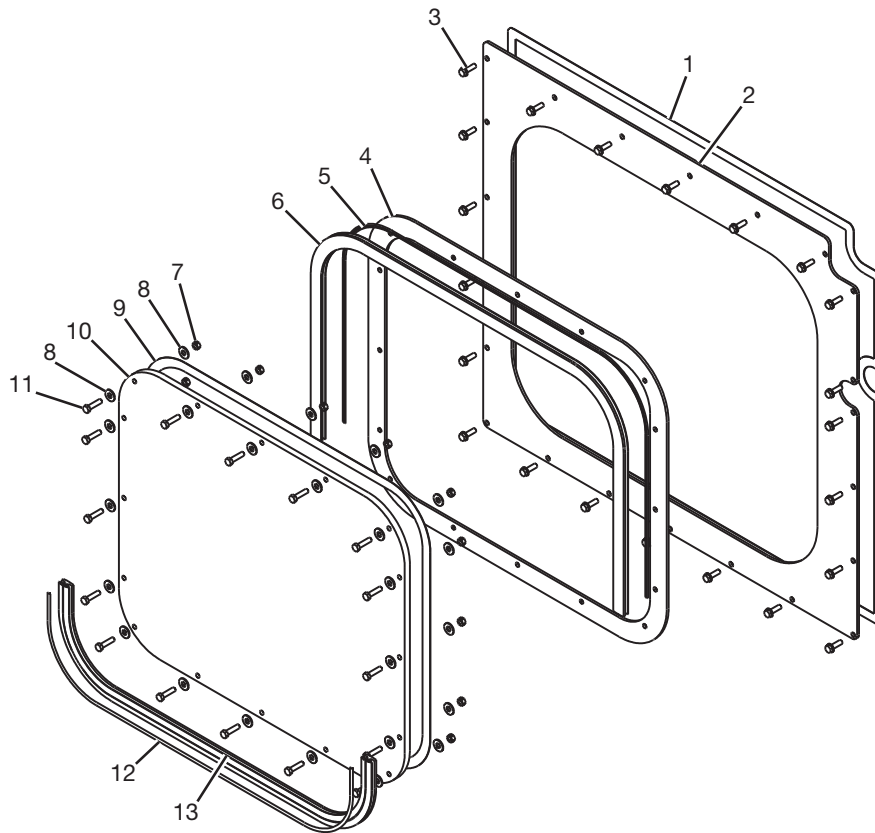

#	QTY.	PART #	DESCRIPTION
1	1	N38324	REAR, SEAL RUBBER 1/4
2	1	N105426	PANEL, MOUNT ESCAPE
3	22	N28820	SCREW, 5/16 X 3/4 SELF TAPPING
4	1	N105470	PANEL, MOUNT ESCAPE
5	1	N105466	LOCK STRIP, REAR TOP
6	1	N105444	GASKET, WINDOW REAR TOP
7	16	4051	NUT, LOCK 5/16"
8	32	4369	WASHER, 5/16" FLAT
9	1	N105484	SEAL, RUBBER 1/4
10	1	N105472	PANEL, POLY KWIK TRIM
11	16	1141	BOLT, 5/16" X 1-1/4" GR 5 FULL THRD
12	1	N107696	LOCK STRIP, WINDOW REAR
13	1	N107694	GASKET, WINDOW REAR TOP

Parts Identification

Top Cover Assembly (N129683)

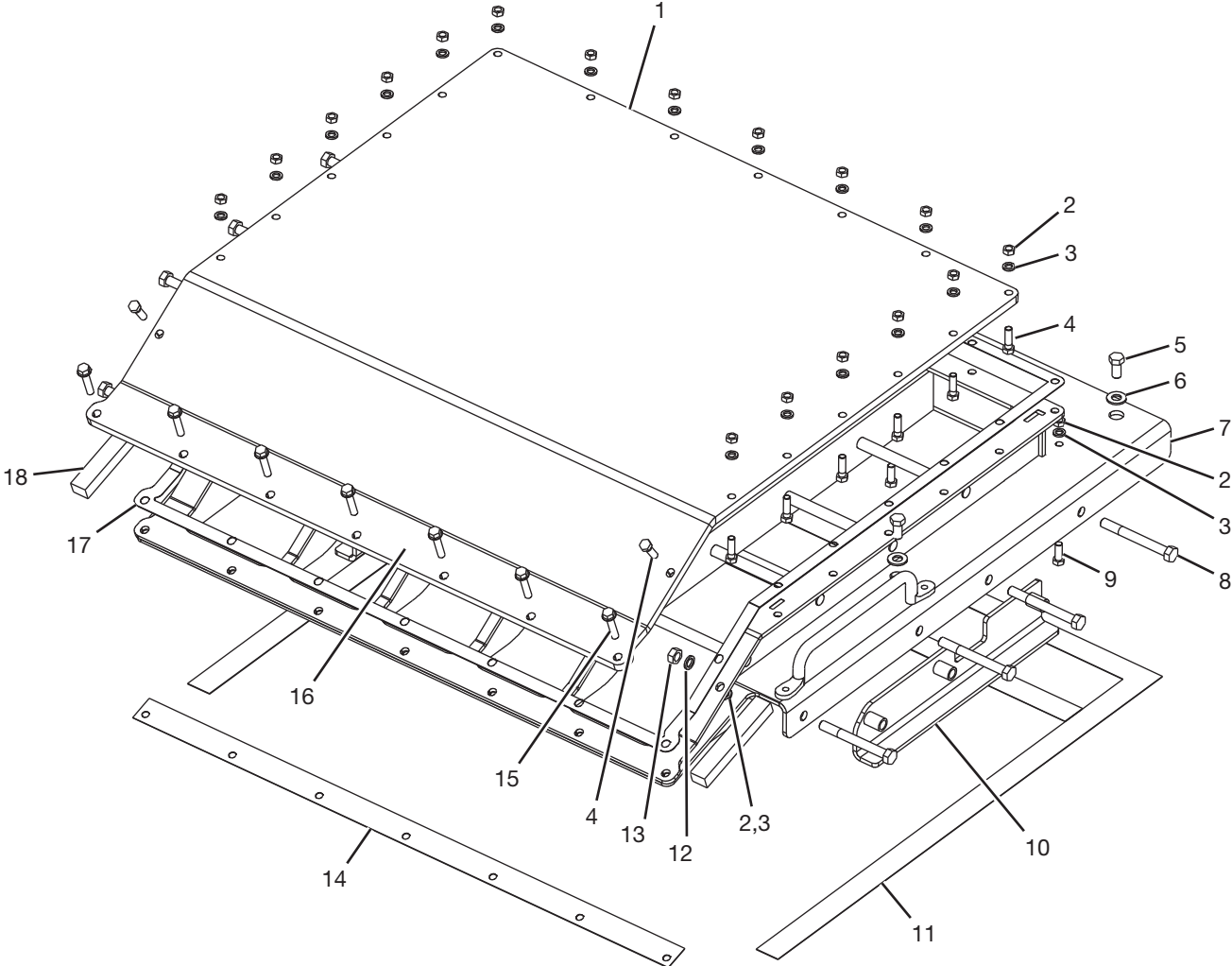

Parts Identification

Top Cover Assembly (N129683)

#	QTY.	PART #	DESCRIPTION
1	1	N129654	PANEL, POLY TOP
2	26	4233	NUT, STANDARD 3/8"
3	26	N16470	WASHER, 3/8 NORDLOCK
4	19	4005	BOLT, 3/8" X 1-1/4" GRADE 5
5	4	N38307	BOLT, M12 X 25 MM
6	4	4068	WASHER, 1/2" SAE FLAT
7	1	N129646	TOP, WELDMENT
8	8	4201	BOLT, 1/2" X 4-1/2" GR 5
9	7	4195	BOLT, 3/8" X 1" GRADE 5
10	1	N38068	COVER, SPACER LEFT
11	1	N38219	SEAL, RUBBER TOP 1/2
12	8	N16472	WASHER, 1/2 NORDLOCK
13	8	4250	NUT, STANDARD 1/2
14	1	N38220	SEAL, RUBBER FRONT 1/2
15	7	N38360	SCREW, 3/8 X 1 3/4 SELF TAPPING
16	1	N38060	COVER, SPACER RIGHT
17	1	N38218	SEAL, RUBBER TOP PANEL 1/2
18	2	N38221	SEAL, RUBBER SIDES 1

Parts Identification

Blade and Track Cover

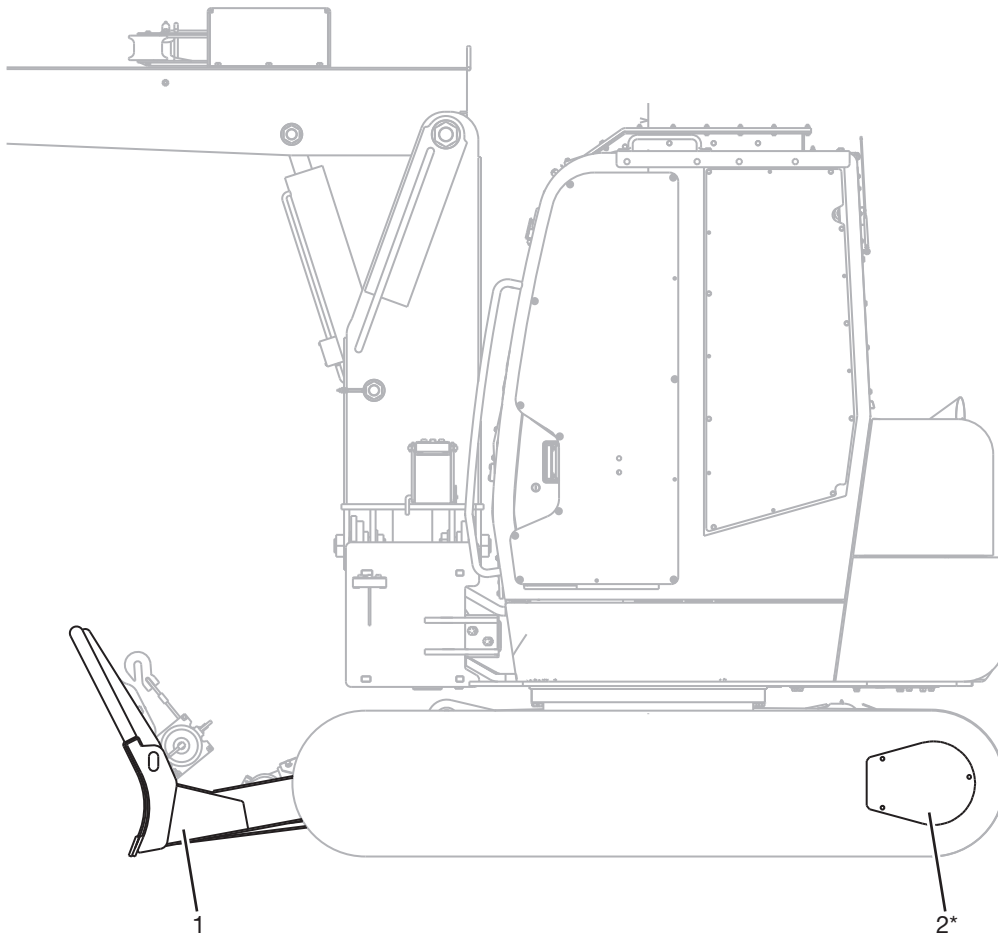

*Item #2 is placed inside of tracks (2 places).

#	QTY.	PART #	DESCRIPTION
1	1	N38071	BLADE, WELDMENT TB260
2	2	N31829	COVER, KWIK TRIM

Cover Plate

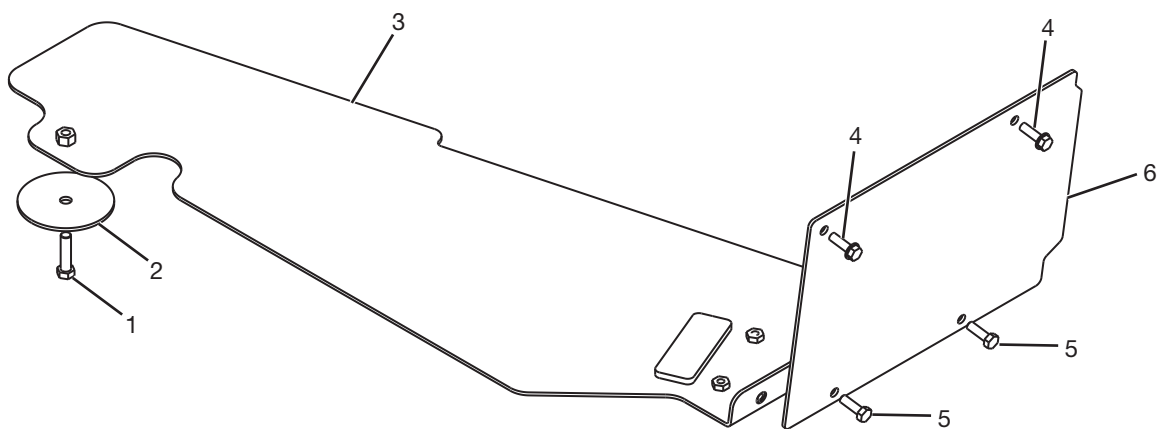

#	QTY.	PART #	DESCRIPTION
1	1	4006	BOLT, 3/8" X 1-1/2" GRADE 5
2	1	N38355	WASHER, .44 X 3.50 X 10GA
3	1	N38356	WELDMENT, MOUNT HYD
4	2	N28237	SCREW, 5/16 X 1 SELF TAPPING
5	2	4203	BOLT, 5/16" X 1" GRADE 5
6	1	N38216	PLATE, COVER

Parts Identification

Fire Extinguisher

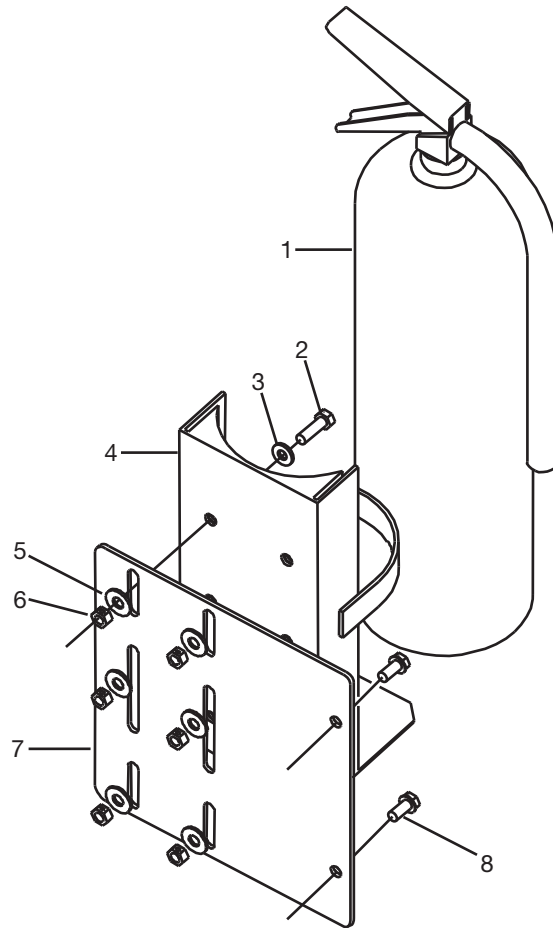

#	QTY.	PART #	DESCRIPTION
1	1	N28326	FIRE EXTINGUISHER, ABC 10LB
2	6	4203	BOLT, 5/16" x 1 GR5
3	6	N16469	WASHER, 5/16 NORDLOCK
4	1	N28329	MOUNT, BRACKET FIRE EXTINGUISHER
5	6	4369	WASHER, 5/16" FLAT
6	6	4051	NUT, LOCK 5/16"
7	1	N38328	MOUNT, FIRE EXTINGUISHER
8	2	N28820	SCREW, 5/16 X 3/4 SELF TAPPING

Machine Decals and Signs

NOTE: All safety related decals are also shown in the Safety Instructions Section along with their location on the machine. See "Safety Decal Locations" starting on page 9.

Check and replace any worn, torn, hard to read or missing decals on your machine.

NOTE: To order a complete Kwik Trim 53 Decal Kit use part number N28465.

Part No. N22763



Part No. N28461



Part No. N28464



Part No. 203264



Part No. N28462



Part No. N28463



Part No. N23506



Part No. N34419



Part No. N34420



Parts Identification

Machine Decals and Signs (Cont'd)

NOTE: Grease point decals N28010 and N28012 are shown in their locations in the Lubrication section. See page 24.

Part No. N28010

Part No. N28012

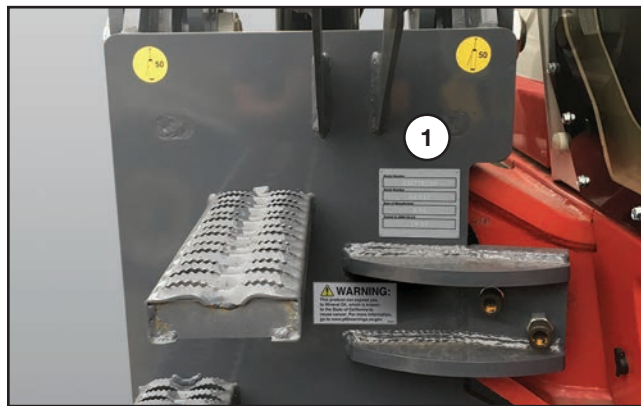
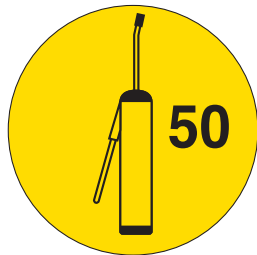
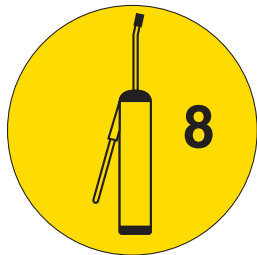

Part No. N28288

1

Model Number	<input type="text"/>
Serial Number	<input type="text"/>
Date of Manufacture	<input type="text"/>
Tested to ANSI 92.2-C	<input type="text"/>



Part No. N151283

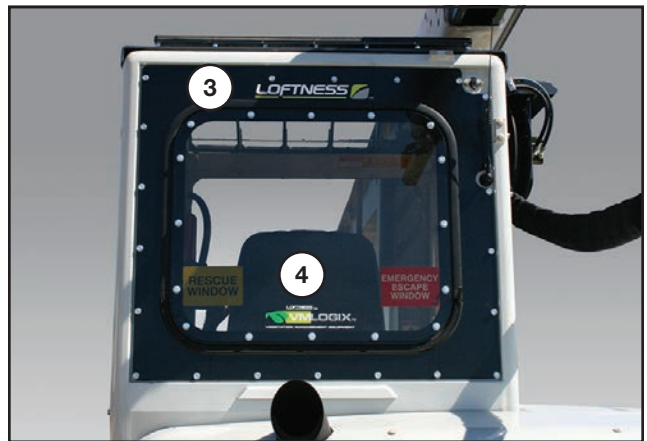

Part No. N26974



Part No. N28577



Machine Decals and Signs (Cont'd)



Part No. N28503

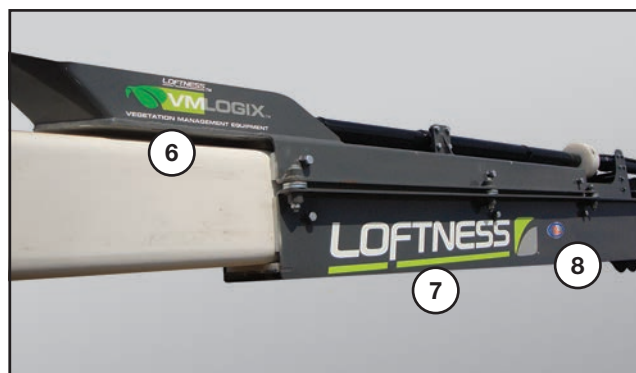
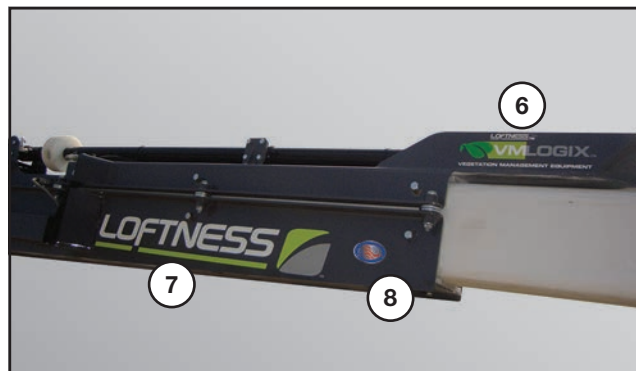

Part No. N28576



Part No. N26972



Part No. N13517



Parts Identification

Takeuchi TB260 Filters

DESCRIPTION	Takeuchi Part No.	WIX Part No.	NAPA Part No.	Loftness Part No.
Engine Oil	Y129150-35153	51334	1334	
Engine Inner Air	19111-12002	49463	9463	
Engine Primary Air	19111-12001	49462	9462	
Fuel Filter	Y129A00-55800			N118120
Water Separator Element	Y129A00-5573030			N118124
Hydraulic Filter Element	15511-03900			N38398
Pilot Oil Element	15512-00601	57105	7105	N38397
Cab Air Filter	05546-03101			N118126
Cab Fresh Air Filter	05546-00025			N118128

Refer to the List of Consumables in the Maintenance section of the Takeuchi TB260 Operator's Manual for the filter and element maintenance schedules. The schedules also include page references for replacement procedures.

Specifications

DESCRIPTION	KWIK TRIM
Power Unit	Takeuchi TB260; 47.6 HP Diesel Engine
Boom	53 ft. (16.15 m) Fiberglass, Non-conductive
	Telescoping
Cutting Blade	24 in. (60.96 cm) Carbide-tipped
Saw Blade Operating Speed	3,000 RPM
Weight	14,000 lbs. (6,350 kg)
Fuel Consumption	1.6 Gallon (6.05 liter) per Hour
Hydraulic Winch	12,000 lbs. (5,443 kg) Capacity
Rollover Protection	ROPS/FOPS/OPS Certified Cab
Windows	1/2 in. Tinted Polycarbonate
	Custom Full-view Tinted Polycarbonate Skylight with Guard
Certifications	Boom – ANSI A92-2 Category C ROPS - ISO3471, ISO12117-2, 8082-2 OPS - ISO8084 FOPS - ISO8083

Appendix

Dimensions

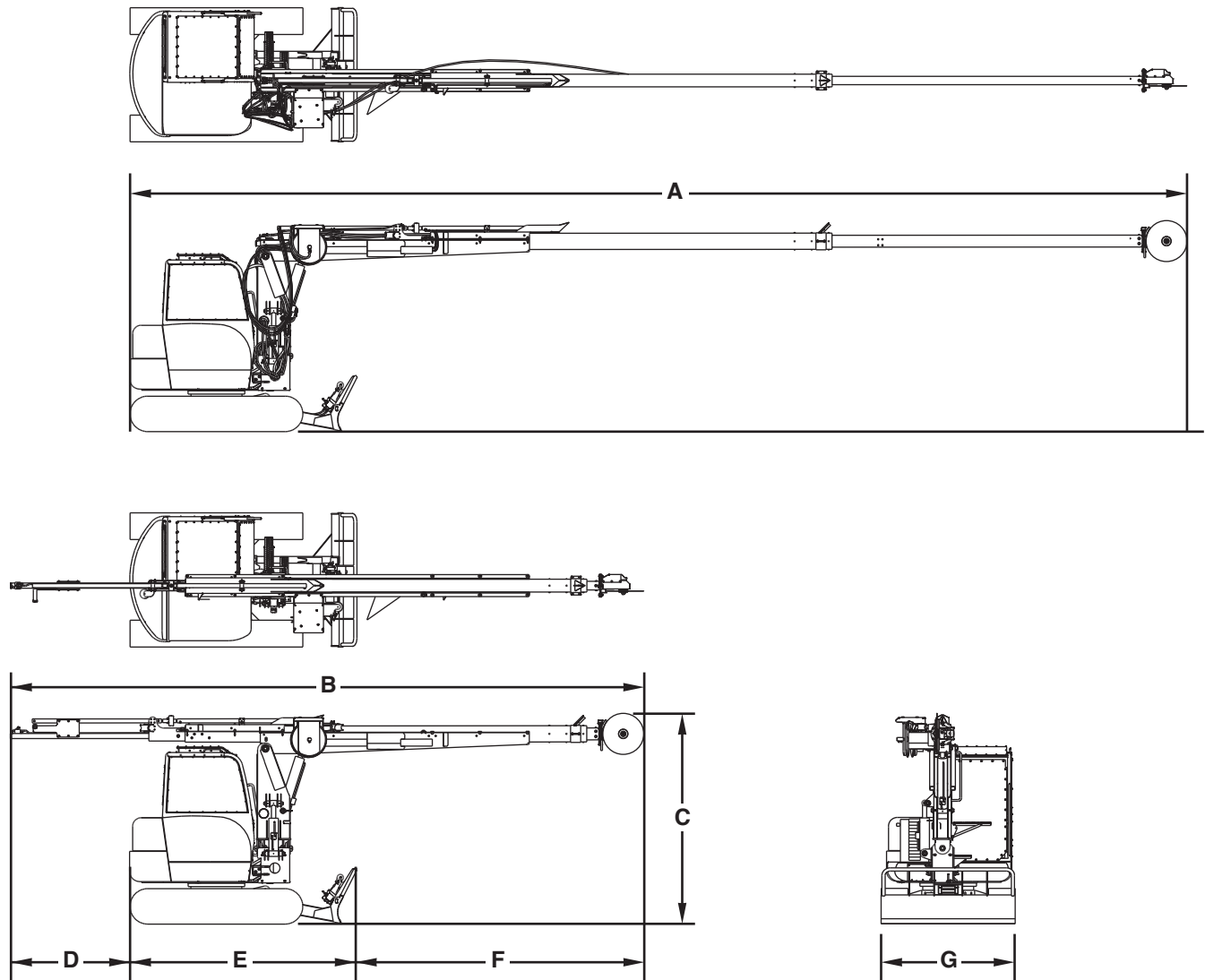

DESCRIPTION	KWIK TRIM
Overall Length, Boom Extended (A)	51 ft. 9 in. (15.77 m)
Overall Length, Boom Withdrawn (B) (Transport)	31 ft. (9.45 m)
Overall Height (C)	10 ft. 4 in. (3.14 m)
Rear Extension (with Boom Withdrawn) (D)	5 ft. 9 in. (1.75 m)
Excavator Length (E)	11 ft. (3.35 m)
Front Extension (with Boom Withdrawn) (F)	14 ft. 3 in. (4.34 m)
Width (G)	6 ft. 7 in. (2 m)
Weight	14,000 lbs. (6,350 kg)

Torque Specifications

Inches Hardware and Lock Nuts

TORQUE CHARTS

Minimum Hardware Tightening Torques

Normal Assembly Applications
(Standard Hardware and Lock Nuts)

SAE Gr. 2 Nominal Size	SAE Grade 5		SAE Grade 8		LOCK NUTS			
	Unplated or Plated Silver	Plated W / ZnCr Gold	Unplated or Plated Silver	Plated W / ZnCr Gold	Unplated or Plated Silver	Plated W / ZnCr Gold	Grade W / Gr. 5 Bolt	Grade W / Gr. 8 Bolt
1/4	55 in.-lb. (6.2 N•m)	72 in.-lb. (8.1 N•m)	86 in.-lb. (9.7 N•m)	112 in.-lb. (12.6 N•m)	121 in.-lb. (13.6 N•m)	157 in.-lb. (17.7 N•m)	61 in.-lb. (6.9 N•m)	86 in.-lb. (9.8 N•m)
5/16	115 in.-lb. (13 N•m)	149 in.-lb. (17 N•m)	178 in.-lb. (20 N•m)	229 in.-lb. (26 N•m)	250 in.-lb. (28 N•m)	324 in.-lb. (37 N•m)	125 in.-lb. (14 N•m)	176 in.-lb. (20 N•m)
3/8	17 ft.-lb. (23 N•m)	22 ft.-lb. (30 N•m)	26 ft.-lb. (35 N•m)	34 ft.-lb. (46 N•m)	37 ft.-lb. (50 N•m)	48 ft.-lb. (65 N•m)	19 ft.-lb. (26 N•m)	26 ft.-lb. (35 N•m)
7/16	27 ft.-lb. (37 N•m)	35 ft.-lb. (47 N•m)	42 ft.-lb. (57 N•m)	54 ft.-lb. (73 N•m)	59 ft.-lb. (80 N•m)	77 ft.-lb. (104 N•m)	30 ft.-lb. (41 N•m)	42 ft.-lb. (57 N•m)
1/2	42 ft.-lb. (57 N•m)	54 ft.-lb. (73 N•m)	64 ft.-lb. (87 N•m)	83 ft.-lb. (113 N•m)	91 ft.-lb. (123 N•m)	117 ft.-lb. (159 N•m)	45 ft.-lb. (61 N•m)	64 ft.-lb. (88 N•m)
9/16	60 ft.-lb. (81 N•m)	77 ft.-lb. (104 N•m)	92 ft.-lb. (125 N•m)	120 ft.-lb. (163 N•m)	130 ft.-lb. (176 N•m)	169 ft.-lb. (229 N•m)	65 ft.-lb. (88 N•m)	92 ft.-lb. (125 N•m)
5/8	83 ft.-lb. (112 N•m)	107 ft.-lb. (145 N•m)	128 ft.-lb. (174 N•m)	165 ft.-lb. (224 N•m)	180 ft.-lb. (244 N•m)	233 ft.-lb. (316 N•m)	90 ft.-lb. (122 N•m)	127 ft.-lb. (172 N•m)
3/4	146 ft.-lb. (198 N•m)	189 ft.-lb. (256 N•m)	226 ft.-lb. (306 N•m)	293 ft.-lb. (397 N•m)	319 ft.-lb. (432 N•m)	413 ft.-lb. (560 N•m)	160 ft.-lb. (217 N•m)	226 ft.-lb. (306 N•m)
7/8	142 ft.-lb. (193 N•m)	183 ft.-lb. (248 N•m)	365 ft.-lb. (495 N•m)	473 ft.-lb. (641 N•m)	515 ft.-lb. (698 N•m)	667 ft.-lb. (904 N•m)	258 ft.-lb. (350 N•m)	364 ft.-lb. (494 N•m)
1	213 ft.-lb. (289 N•m)	275 ft.-lb. (373 N•m)	547 ft.-lb. (742 N•m)	708 ft.-lb. (960 N•m)	773 ft.-lb. (1048 N•m)	1000 ft.-lb. (1356 N•m)	386 ft.-lb. (523 N•m)	545 ft.-lb. (739 N•m)

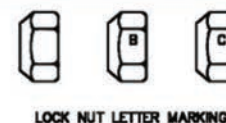
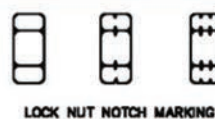
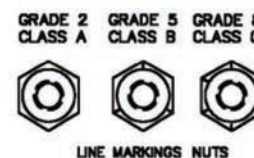
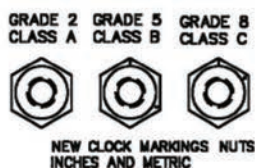
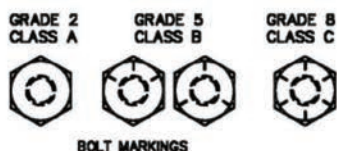

Appendix

Torque Specifications (Cont'd)

Metric Hardware and Lock Nuts

TORQUE CHARTS
Minimum Hardware Tightening Torques
Normal Assembly Applications
(Metric Hardware and Lock Nuts)

Nominal Size	Class 5,8		Class 8,8		Class 10,9		Lock nuts Class 8 W / CL. 8,8 Bolt
	Unplated or Plated Silver	Plated W / ZnCr Gold	Unplated or Plated Silver	Plated W / ZnCr Gold	Unplated or Plated Silver	Plated W / ZnCr Gold	
M4	1.7 N•m (15 in.-lb.)	2.2 N•m (19 in.-lb.)	2.6 N•m (23 in.-lb.)	3.4 N•m (30 in.-lb.)	3.7 N•m (33 in.-lb.)	4.8 N•m (42 in.-lb.)	1.8 N•m (16 in.-lb.)
M6	5.8 N•m (51 in.-lb.)	7.6 N•m (67 in.-lb.)	8.9 N•m (79 in.-lb.)	12 N•m (102 in.-lb.)	13 N•m (115 in.-lb.)	17 N•m (150 in.-lb.)	6.3 N•m (56 in.-lb.)
M8	14 N•m (124 in.-lb.)	18 N•m (159 in.-lb.)	22 N•m (195 in.-lb.)	28 N•m (248 in.-lb.)	31 N•m (274 in.-lb.)	40 N•m (354 in.-lb.)	15 N•m (133 in.-lb.)
M10	28 N•m (21 ft.-lb.)	36 N•m (27 ft.-lb.)	43 N•m (32 ft.-lb.)	56 N•m (41 ft.-lb.)	61 N•m (45 ft.-lb.)	79 N•m (58 ft.-lb.)	30 N•m (22 ft.-lb.)
M12	49 N•m (36 ft.-lb.)	63 N•m (46 ft.-lb.)	75 N•m (55 ft.-lb.)	97 N•m (72 ft.-lb.)	107 N•m (79 ft.-lb.)	138 N•m (102 ft.-lb.)	53 N•m (39 ft.-lb.)
M16	121 N•m (89 ft.-lb.)	158 N•m (117 ft.-lb.)	186 N•m (137 ft.-lb.)	240 N•m (177 ft.-lb.)	266 N•m (196 ft.-lb.)	344 N•m (254 ft.-lb.)	131N•m (97 ft.-lb.)
M20	237 N•m (175 ft.-lb.)	307 N•m (226 ft.-lb.)	375 N•m (277 ft.-lb.)	485 N•m (358 ft.-lb.)	519 N•m (383 ft.-lb.)	671 N•m (495 ft.-lb.)	265 N•m (195 ft.-lb.)
M24	411 N•m (303 ft.-lb.)	531 N•m (392 ft.-lb.)	648 N•m (478 ft.-lb.)	839 N•m (619 ft.-lb.)	897 N•m (662 ft.-lb.)	1160 N•m (855 ft.-lb.)	458 N•m (338 ft.-lb.)

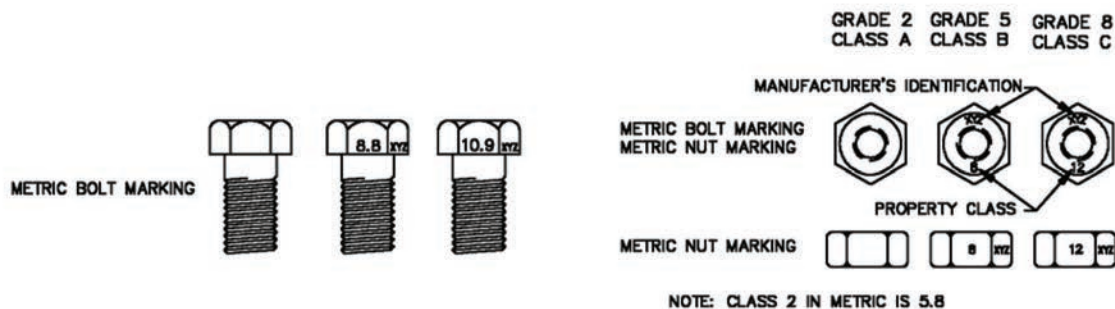



www.loftness.com

Loftness Specialized Equipment, Inc.
650 So. Main Street • PO Box 337 • Hector, MN 55342
Tel: 320.848.6266 • Fax: 320.848.6269 • Toll Free: 1.800.828.7624

Printed in USA
© Loftness 2020