



Carbide Cutter

51CCH • 61CCH • 71CCH

Owner's Manual and Parts Book
(Originating w / Serial Number 42-751)



Model Number: _____
Serial Number: _____
Date of Purchase: _____

LOFTNESS ™

LOFTNESS SPECIALIZED EQUIPMENT, INC.

WARRANTY POLICY

The warranty policy begins upon delivery of the unit to the original customer.

All Loftness products have a one (1) year warranty policy.

If any Loftness product is used as rental equipment, the warranty period extends for only 30 days from the delivery date to the original customer.

Loftness Specialized Equipment, hereinafter referred to as LOFTNESS, a manufacturer of quality machinery since 1956, warrants new LOFTNESS machinery and/or attachments at the time of delivery to the original purchaser, to be free from defects in material and workmanship when properly set up and operated in accordance with the recommendations set forth in the LOFTNESS Operator's Manual.

LOFTNESS' liability for any defect with respect to accepted goods shall be limited to repairing the goods at an authorized dealer or other LOFTNESS designated location, or replacing them as LOFTNESS shall elect. The above shall be in accordance with LOFTNESS warranty adjustment policies. This warranty shall not apply to any machine or attachment which shall have been repaired or altered outside the LOFTNESS factory or authorized LOFTNESS dealership or in any way so as in LOFTNESS' judgment, to affect its stability or reliability, nor which has been subject to misuse, negligence or accident, nor to any machine or attachment which shall not have been operated in accordance with LOFTNESS' printed instructions or beyond the company recommended machine rated capacity.

WARRANTY REQUIREMENTS

Warranty registration form must be filled out and returned to Loftness Specialized Equipment to validate all future warranty claims.

LIMITATIONS OF WARRANTY

LOFTNESS products are designed to provide years of dependable service when proper use and maintenance is adhered to. The potential for misuse in many applications exists, therefore a limited warranty is provided as follows:

Auger wear is considered a maintenance item, and its life is dependant on the material being conveyed. Tires are warranty of the manufacturer of the tire.

To receive a warranty claim, a return authorization from LOFTNESS must be obtained. The failed part may then be returned in an untampered status. This warranty does not include freight or delivery charges incurred when returning machinery for servicing. Dealer mileage, service calls and pick-up/delivery charges are the customer's responsibility.

EXCLUSIONS OF WARRANTY

Except as otherwise expressly stated herein, LOFTNESS makes no representation or warranty of any kind, expressed or implied, and makes no warranty of merchantability in respect to its machinery and/or attachments and makes no warranty that its machinery and/or attachments are fit for any particular purpose. LOFTNESS shall not be liable for incidental or consequential damages for any breach of warranty, including but not limited to inconvenience, rental or replacement equipment, loss of profits or other commercial loss. Upon purchase the buyer assumes all liability, all personal injury and property damage resulting from the handling, possession or use of the goods by the buyer.

No agent, employee, or representative of LOFTNESS has any authority to bind LOFTNESS to any affirmation, representation or warranty concerning its machinery and/or attachments except as specifically set forth herein.

April 2009

LOFTNESS ™

LOFTNESS

SPECIALIZED EQUIPMENT. UNLIMITED INNOVATION.

650 South Main Street
Hector, MN 55342 USA
loftness.com 320-848-6266
US & Canada 800-828-7624



International: 320-848-6266 Fax: 320-848-6269 Parts Fax: 320-848-6055 E-mail: info@loftness.com Web Address: www.loftness.com

WARRANTY REGISTRATION

Dealer No.: _____
Dealer Name: _____ Dealer Phone: _____
Shipping Address: _____
Mailing Address: _____
City: _____ State: _____ Zip: _____
Invoice No.: _____ Part No.: _____
Model No.: _____ Serial No.: _____

P
L
E
A
S
E

P
R
I
N
T

FOLLOWING INFORMATION MUST BE FILLED IN COMPLETELY FOR WARRANTY:

Customer:
Last Name: _____ First _____ Middle Initial _____
Mailing Address: _____
City: _____ State: _____ Zip: _____
County: _____ Warranty (Delivered) Date
Phone: _____ Month _____ Day _____ Year _____

DEALER

The machine was properly set up, adjusted and inspected before delivery. The following items were explained to the purchaser.

- * How to operate machine properly as shown in the owner's manual.
- * The importance of safety precaution, safety equipment and preventative maintenance.
- * Loftness Warranty for this machine.

X

Dealer's Signature

Date

PURCHASER

I have received and reviewed the operator's manual for the above machine and understand the proper and safe operation as well as the applicable warranty outlined therein.

A customer's manual is included with each machine.

The unit was delivered to me in satisfactory condition.

X

Purchaser's Signature

Date

Customer Copy

LOFTNESS

SPECIALIZED EQUIPMENT. UNLIMITED INNOVATION.

650 South Main Street
Hector, MN 55342 USA
loftness.com 320-848-6266
US & Canada 800-828-7624



International: 320-848-6266 Fax: 320-848-6269 Parts Fax: 320-848-6055 E-mail: info@loftness.com Web Address: www.loftness.com

WARRANTY REGISTRATION

Dealer No.: _____
Dealer Name: _____ Dealer Phone: _____
Shipping Address: _____
Mailing Address: _____
City: _____ State: _____ Zip: _____
Invoice No.: _____ Part No.: _____
Model No.: _____ Serial No.: _____

P
L
E
A
S
E

P
R
I
N
T

FOLLOWING INFORMATION MUST BE FILLED IN COMPLETELY FOR WARRANTY:

Customer:
Last Name: _____ First _____ Middle Initial _____
Mailing Address: _____
City: _____ State: _____ Zip: _____
County: _____ Warranty (Delivered) Date
Phone: _____ Month _____ Day _____ Year _____

DEALER

The machine was properly set up, adjusted and inspected before delivery. The following items were explained to the purchaser.

- * How to operate machine properly as shown in the owner's manual.
- * The importance of safety precaution, safety equipment and preventative maintenance.
- * Loftness Warranty for this machine.

X

Dealer's Signature

Date

PURCHASER

I have received and reviewed the operator's manual for the above machine and understand the proper and safe operation as well as the applicable warranty outlined therein.

A customer's manual is included with each machine.

The unit was delivered to me in satisfactory condition.

X

Purchaser's Signature

Date

Loftness Copy

Table of Contents

Warranty

Table of Contents

Ordering Code

Ordering Code	1
Carbide Cutter (Example)	1

Introduction

Owner Information	3
Warranty Policy	3
Serial Number Location	3
Manual Storage	3
Carbide Cutter Features	4
Carbide Cutter Options	4

Safety Instructions

Safety First.	5
Owner's Responsibility	5
Mandatory Shut-Down Procedure	6
Safety Rules.	6
Hydraulic Safety	7
Carbide Cutter Identification	8
Safety Decal Locations	9

Set-up Instructions

Installing the Carbide Cutter to the Loader	13
Checking Rotor Rotation	14
Checking Rotor Speed.	14
Pusher Bar Adjustment	15
Adjusting the Support Stands	15
Skid Adjustment.	16
Rotor Locking Pin Installation	16

Operating Instructions

Getting Started.	17
Operation	17
Log Moving	18

Maintenance

General Maintenance.	19
Maintenance Schedule	19
Lubrication	20
Grease Point Location	20
Overhung Load Adapter.	21
Belt Adjustment	22

Table of Contents

Maintenance (Cont'd)

Tooth Removal and Installation	23
Double Tooth & Double Planer	23
Quadco Teeth	23
Tooth Sharpening (Quadco Option Only)	23
Storage	24
End of Season	24
Beginning of the Season	24
Motor & Sheave Selection Chart	25
Troubleshooting	26

Parts Identification

Carbide Cutter Drive Assembly	28
Carbide Cutter Body Assembly	30
Carbide Cutter Body Assembly (Cont'd)	32
Carbide Cutter Body Assembly (Cont'd)	34
Motor Assembly #530 Open (N28409)	36
Motor Assembly #630 Closed (N28410)	38
Motor Assembly #933 Open 15 Bar (N28472)	40
Motor Assembly #1033 Closed 15 Bar (N28500)	42
Motor Assembly, VOAC 60 (N20840)	44
Overhung Load Adapter (N20901)	45
Variable Motor Assembly, 15 Bar (N28205)	46
Hydraulic Hose Assembly (N28471)	47
Belt Tensioner (N28018)	48
Motor Shield W / Gauge (N15974)	49
Rotor (W / Double Carbide Teeth) 51" (N20083), 61" (N20077), 71" (N20080)	50
Rotor (W / Carbide Planer Teeth) (Optional) 51" (N20576), 61" (N20575), 71" (N21906)	51
Rotor (W / Quadco Planer Teeth) (Optional) 51" (N24689), 61" (N28165), 71" (N28168)	52
Tooth Assembly, Quadco Planer (N24281)	53
Rear Cutter Bar 51" (N20282), 61" (N20281), 71" (N21908)	54
Machine Decals and Signs	55

Appendix

Specifications	59
Dimensions	60
Torque Specifications	61
Inches Hardware and Lock Nuts	61
Metric Hardware and Lock Nuts	62

Ordering Code

Carbide Cutter (Example)

The ordering code will consist of two numbers (machine size), three letters (machine type), one letter (cutter type), three numbers (motor system), one letter (sheaves / belt combo), one number (threshold setting), and two letters (options). An example for a carbide cutter of this type would be as shown below.

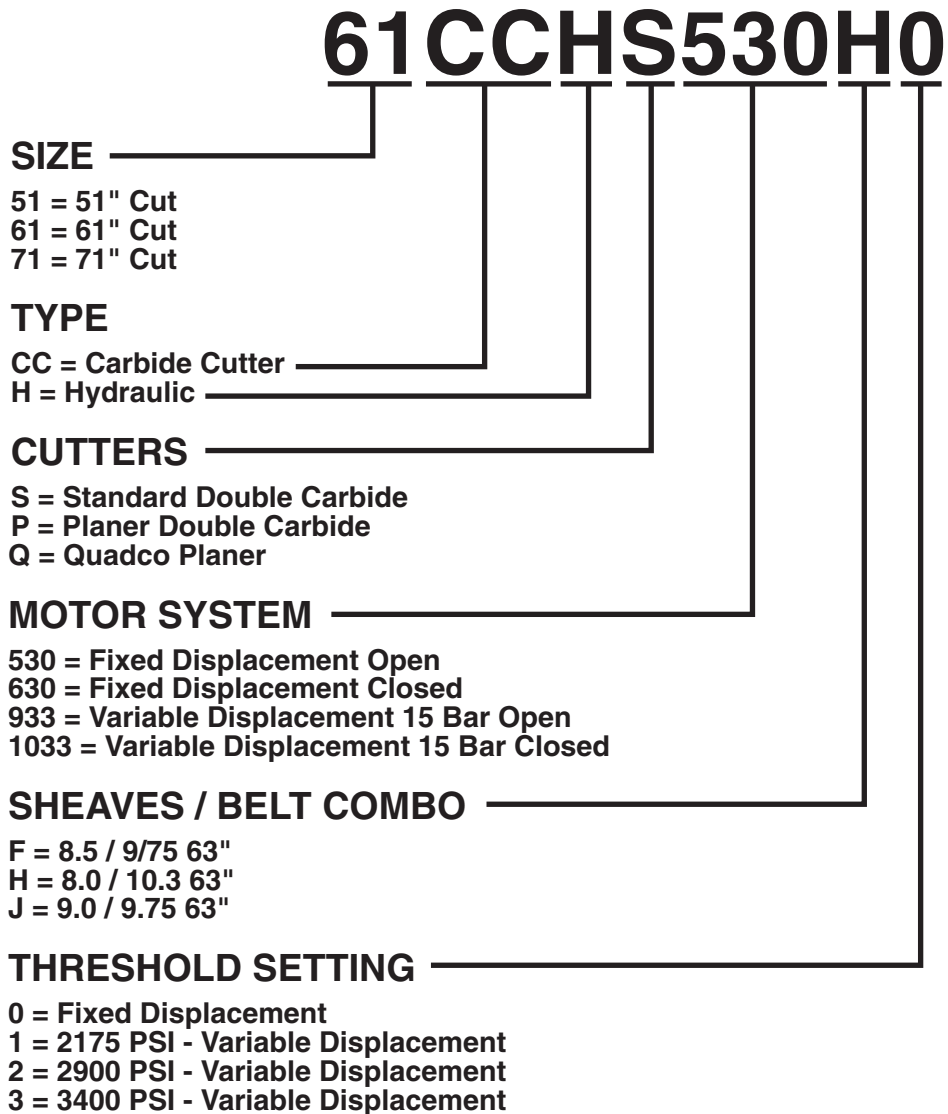



Owner Information

Thank you for your decision to purchase a Carbide Cutter from Loftness. To ensure maximum performance of your machine, it is mandatory that you thoroughly study the owner's manual and follow its recommendations. Proper operation and maintenance are essential to prevent injury or damage and to maximize machine life.

The Loftness Carbide Cutter is an effective, reliable machine used for maintaining grass, weeds, brush and trees. Efficiently cuts and mulches up to 6" diameter material. Intermittently cuts larger diameter material. For best results, operate the machine as low to the ground as possible without the teeth striking ground or other obstructions. Lifting or tilting the shredder increases the risk of flying debris. Because of the high speed of the teeth, the life of the teeth will be reduced if it is operated in rocky terrain or in areas where many obstacles are present. Areas to be mowed should be free of debris such as rocks, bottles, large branches etc. The teeth cut and pulverize the grass, weeds and brush. The shredder deposits cut material over the entire width-of cut, which eliminates bunching or windrowing behind the machine.

Operate and maintain this machine in a safe manner and in accordance with all applicable local, state, and federal codes, regulations and/or laws, and in compliance with on-product labeling and these instructions.

Make sure that all personnel have read this owner's manual and thoroughly understand safe and correct operating, installation and maintenance procedures.

Continuous improvement and advancement of Loftness products may result in changes to your equipment that may not be reflected in this publication. Loftness reserves the right to make product improvements to the machine at any time. Although great care has been taken to ensure the accuracy of this publication, Loftness does not assume any liability for errors or omissions.

Warranty Policy

Be sure to read and understand the Warranty Policy at the beginning of this manual. It is also important that you fill out the Warranty Registration form(s) completely with your dealer so as not to void the warranty.

Serial Number Location

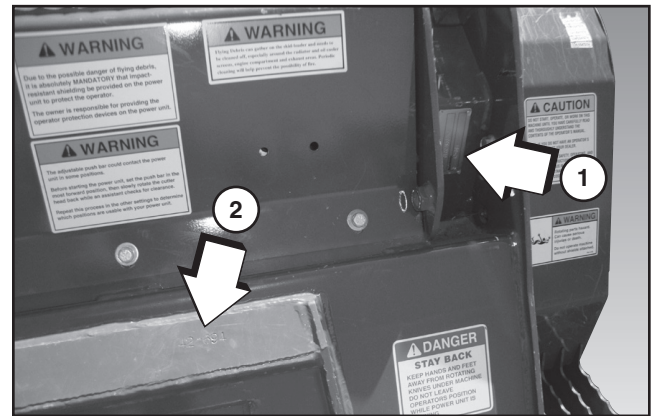

NOTE: Pusher bar arm has been removed for picture clarity.

The arrows above indicate the location of the serial number tag (1) and the location of the serial number stamped into the frame (2).

Always use your model and serial number when requesting information or when ordering parts.

Manual Storage

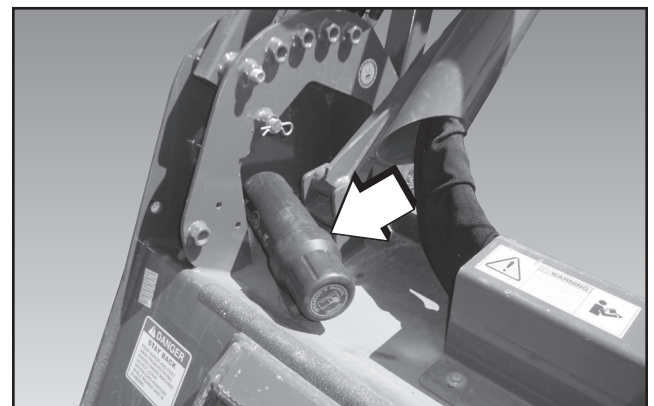

Keep the owner's manual and the entire documentation packet in the storage compartment provided on your Carbide Cutter. The owner's manual must be available for all operators.

Introduction

Carbide Cutter Features

- Downward Rotation Design
- Premium Strength Steel Body & Rotor
- Front Mounted
- Hydraulic Driven
- Universal Skid-Steer Mount
- Adjustable Tree Pusher
- Claw Hooks On Tree Pusher
- 17 In. (43 cm) Diameter Rotor (1600 - 2150 RPM)
- 2 3/16 In. (56 mm) Rotor Bearings
- Anti Wrap Bearing Protection
- Heavy Duty Bearing Block
- Fixed Or Variable Displacement Piston Type Motor
- Dual Cross-Over Relief Protection
- Pressure Gauge
- Steel Chain Deflectors
- Four (4) - Groove Banded Belt
- Tapered-Lock Sheaves
- Spring-Loaded Belt Tensioner
- Skid Shoes - Adjustable 1 - 3 in. (25.4 - 76.2 mm)
- Hydraulic Hoses and Hose Holder
- Shear Bar

Carbide Cutter Options

- Carbide Planer Teeth
- Quadco Planer Teeth (Sharpenable)

Safety First



Safety Alert Symbol

This message alert symbol identifies important safety messages on the machine and in the owner's manual. When you see this symbol, be alert to the possibility of personal injury and carefully read the message that follows.

In the owner's manual and on decals used on the machine the words **DANGER, WARNING, CAUTION, IMPORTANT, and NOTE** are used to indicate the following:

DANGER: This word warns of immediate hazards which, if not avoided, will result in severe personal injury or death. The color associated with Danger is RED.



WARNING: This word refers to a potentially hazardous situation which, if not avoided, could result in severe personal injury or death. The color associated with Warning is ORANGE.

CAUTION: This word refers to a potentially hazardous or unsafe situation that, if not avoided, may result in minor or moderate injury. It may also be used to alert against unsafe practices. The color associated with Caution is YELLOW.

IMPORTANT: Highlights information that must be heeded.

NOTE: A reminder of other related information that needs to be considered.

If Safety Decals on this machine are ISO two panel pictorial, decals are defined as follows:

- The first panel indicates the nature of the hazard.
- The second panel indicates the appropriate avoidance of the hazard.
- Background color is YELLOW.
- Prohibition symbols such as  and  if used, are RED.

Be certain all machine operators are aware of the dangers indicated by safety decals applied to the machine, and be certain they follow all safety decal instructions. Contact Loftness for safety decal replacement.

Loftness cannot anticipate every possible circumstance that may involve a potential hazard. The warnings in this owner's manual are not all inclusive.

Owner's Responsibility

Due to the potential danger of flying debris, it is the owner's responsibility and is "**ABSOLUTELY MANDATORY** that **IMPACT-RESISTANT SHIELDING**" be installed on the machine to protect the operator.

It is **ABSOLUTELY MANDATORY** that all personnel read and follow all safety precautions before operating the machine and attachment.

Make sure that all personnel have read this owner's manual, and thoroughly understand safe and correct installation, operation, and maintenance procedures.

Operate and maintain this machine in a safe manner and in accordance with all applicable local, state, and federal codes, regulations and/or laws; and in compliance with on-product labeling and this owner's manual instructions.

Make sure that all personnel know how to stop the machine and attachment by disengaging all controls. See "Mandatory Shut-Down Procedure" on page 6.

Make sure the attachment is installed on the machine correctly before being placed in service. At regular intervals thereafter, the attachment should be serviced in accordance with procedures outlined in this owner's manual.

Safety Instructions

Mandatory Shut-Down Procedure

- Stop the machine and attachment on a level surface and lower the attachment to the ground.
- Move throttle to idle position.
- Disengage all power to the attachment.
- Shut off engine and remove the key.

Wait until the rotor has stopped completely before inspecting the attachment.

Safety Rules

These are general safety considerations. Additional precautions may be necessary to operate your machine in a safe manner. Be certain you are operating your machine in accordance with all safety codes, OSHA rules and regulations, insurance requirements and local, state, and federal laws.

- Read and observe all warnings decals on the machine before attempting to operate the attachment. Do not attempt to operate this attachment unless all factory devices and decals are in place. Keep safety decals clean of dirt and grime. Keep all guards, shields and decals in place.
- Remove from area of operation all foreign objects such as bottles, rocks, wire, etc., that might become tangled in the rotor, causing damage to the machine or be thrown striking other objects.
- Do not allow any people and animals within 300 feet of the machine and attachment during operation.
- Do not allow anyone to operate the attachment until he or she has read the owner's manual and is completely familiar with all safety precautions. Keep the work area clear of all unauthorized personnel.
- Do not allow persons under the influence of alcohol, medications, or other drugs that can impair judgment or cause drowsiness to operate or maintain the machine.
- Always use an approved roll bar and seat belt for safe operation. Overturning a machine without a roll bar and seat belt can result in injury or death.
- Use the handholds and step plates when getting on and off the machine to prevent falls. Keep steps and platform cleared of mud and debris.
- Always have an operator in the machine while the attachment is in operation. Never leave the machine and attachment running and unattended.
- Operate the attachment only from the operator's seat.
- Keep your feet on the pedals, (floor plates) seat belt fastened snugly and seat bar lowered, (if equipped), when operating the attachment.
- The adjustable push bar could contact the machine in some positions. Before starting the power unit, set the push bar in the most forward position, then slowly rotate the attachment back while an assistant checks for clearance. Repeat this process in the other settings to determine which positions are usable with your machine.
- Never attempt to make any adjustments while the attachment is running or the key is in the "ON" position in the machine. Before leaving the operator's position, disengage power to the attachment, shut off engine and remove ignition key.
- Disengage auxiliary hydraulics and place all machine controls in neutral and engage the parking brake before starting the engine.
- Become familiar with and know how to operate all safety devices and controls on the machine and attachment before attempting to operate. Know how to stop the machine and attachment before starting it.
- Repeated impact of the knives with hard objects can cause excessive wear and damage to the skid-steer or attachment. Be sure to maintain recommended ground clearance as specified in this manual.
- Should excessive vibration occur, disengage the auxiliary hydraulics immediately and shut off engine. Do not continue to operate the attachment until the problem has been determined and corrected.
- Do not start, operate, or work on this attachment until you have carefully read and thoroughly understand the contents of this manual and the operator's manual for your machine.

Safety Instructions

- Keep children, bystanders and other workers off and away from the machine and attachment during operation. No riders allowed.
- Before inspecting, cleaning, lubricating, adjusting or servicing any part of the attachment, always exercise the Mandatory Shut-Down Procedure. See “Mandatory Shut-Down Procedure” on page 6. After service has been performed, be sure to restore all guards, shields and covers to their original position.
- Make sure the operator's area is clear of any distracting objects. Keep work areas clean and free of grease and oil to avoid slipping or falling.
- Make sure all controls, (levers, pedals and switches), are in NEUTRAL position before starting the engine.
- Before leaving the operator's position for ANY reason or allowing anyone to approach the machine and attachment, always perform the mandatory shutdown procedure.
- Do not wear loose hanging clothes, neckties or jewelry around rotating parts. Long hair is to be placed under a cap or hat. These precautions will help prevent you from becoming caught in any moving parts on the machine and attachment.
- Before working under the attachment, be certain it is securely blocked!
- Do wear safety glasses, ear protection, respirators, gloves, hard hats, safety shoes and other protective clothing when required.
- Periodically check all guards, shields and structural members. Replace or repair anything that could cause a potential hazard.
- Do not replace components or parts with other than factory-recommended service parts. To do so may decrease the effectiveness of the machine.
- It is the operator's responsibility to be aware of machine and attachment operation and work area hazards at all times.
- Never operate the attachment without adequate light and visibility.
- Keep hands and feet clear! Never step over or climb over the attachment while the rotor is engaged or the engine is running; entanglement could occur.
- Operators are responsible to know the location and function of all guards and shields including but not limited to belt drives and rotor. Operators are responsible to make certain that all guards are in place when operating the machine and attachment.
- Operators are responsible to be aware of safety hazard areas and follow instructions on warning, caution, or danger decals applied to the machine.
- Know the area before operating the machine. Be aware of power lines or other equipment.
- Do not lubricate parts while the machine is running.
- Do not smoke while servicing the machine.

Hydraulic Safety

- The hydraulic system is under high pressure. Make sure all lines and fittings are tight and in good condition. These fluids escaping under high pressure can have sufficient force to penetrate skin and cause serious injury.
- Never check for leaks by using any part of your body to feel for escaping fluid.

Safety Instructions

Carbide Cutter Identification

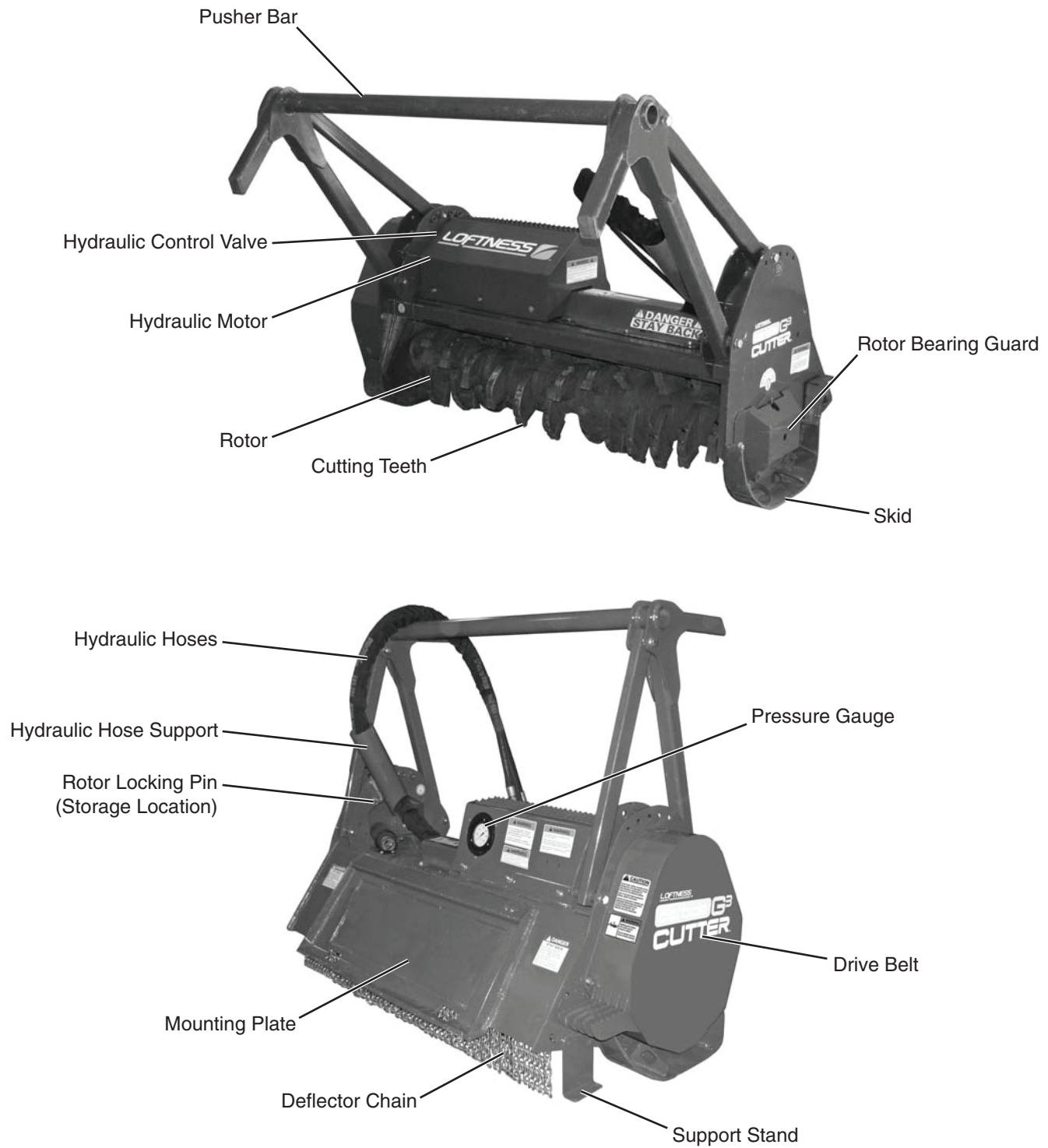

Safety Decal Locations

Check and replace any worn, torn, hard to read or missing safety decals on your machine.

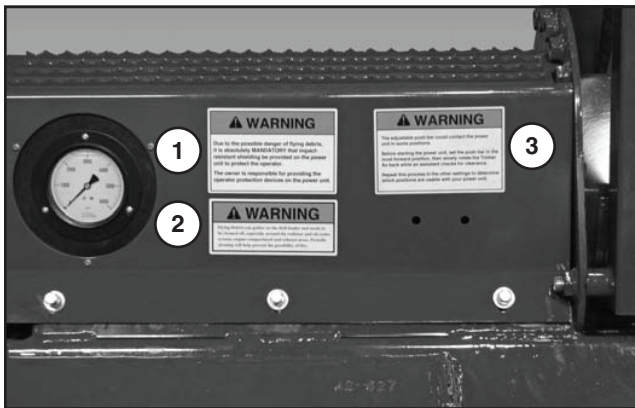

1 **WARNING**

Due to the possible danger of flying debris, it is absolutely MANDATORY that impact-resistant shielding be provided on the power unit to protect the operator.

The owner is responsible for providing the operator protection devices on the power unit.

Part No. N17013

2 **WARNING**

Flying Debris can gather on the skid-loader and needs to be cleaned off, especially around the radiator and oil cooler screens, engine compartment and exhaust areas. Periodic cleaning will help prevent the possibility of fire.

Part No. N20661

3 **WARNING**

The adjustable push bar could contact the power unit in some positions.

Before starting the power unit, set the push bar in the most forward position, then slowly rotate the cutter head back while an assistant checks for clearance.

Repeat this process in the other settings to determine which positions are usable with your power unit.

Part No. N17014



4 **WARNING**

Rotor must be stabilized with the rotor locking pin to prevent accidental rotation any time the rotor is exposed for service work.

Do Not Remove the locking pin for any reason when one or more knives are missing from the rotor assembly. The imbalance could cause the rotor to turn without warning, causing serious personal injury.

Part No. N16759



5 **DANGER STAY BACK**

Part No. 4334

Safety Instructions

Safety Decal Locations (Cont'd)

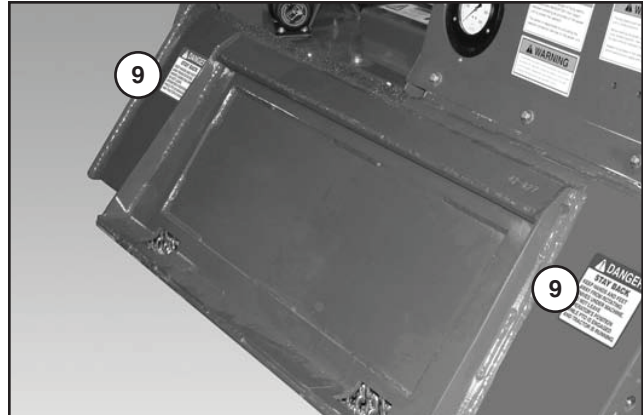
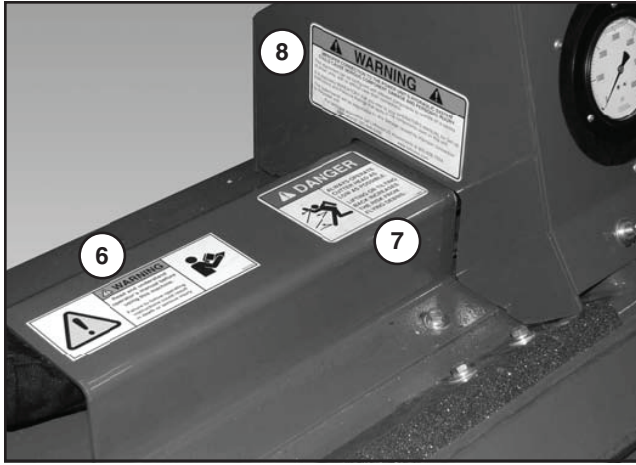

Part No. N22763



Part No. N28386



Part No. N13863

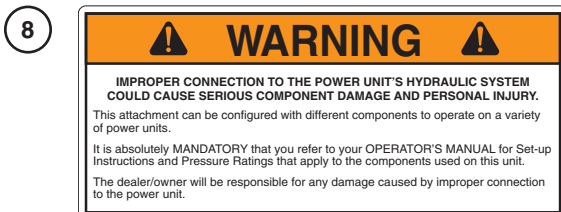

Part No. N28385

Safety Decal Locations (Cont'd)

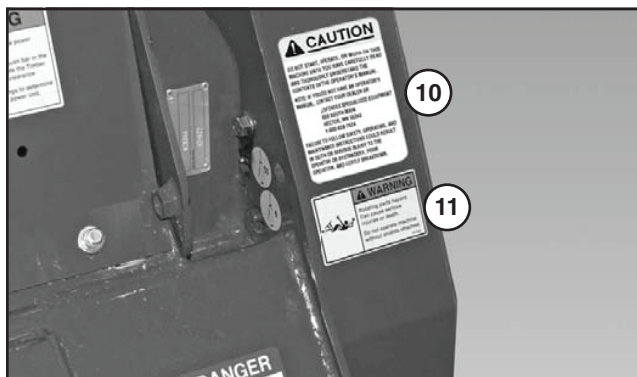

10



DO NOT START, OPERATE, OR WORK ON THIS MACHINE UNTIL YOU HAVE CAREFULLY READ AND THOROUGHLY UNDERSTAND THE CONTENTS OF THE OPERATOR'S MANUAL.

NOTE: IF YOU DO NOT HAVE AN OPERATOR'S MANUAL, CONTACT YOUR DEALER OR

**LOFTNESS SPECIALIZED EQUIPMENT
650 SOUTH MAIN
HECTOR, MN 55342
1-800-828-7624**

FAILURE TO FOLLOW SAFETY, OPERATING, AND MAINTENANCE INSTRUCTIONS COULD RESULT IN DEATH OR SERIOUS INJURY TO THE OPERATOR OR BYSTANDERS, POOR OPERATION, AND COSTLY BREAKDOWN.

Part No. 4256

11

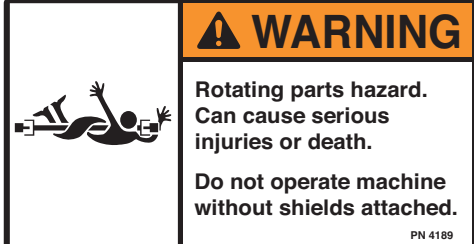

**Rotating parts hazard.
Can cause serious injuries or death.**

Do not operate machine without shields attached.

PN 4189

Part No. 4189



Installing the Carbide Cutter to the Loader

Fully raise the attachment-locking levers on the loader mounting plate.



Tilt the loader mounting plate ahead. Drive forward with the loader and hook the top edge of the loader mounting plate under the top flange (1) on the carbide cutter mounting plate. Be careful not to damage the locking levers on the loader mounting plate.

Tilt the loader mounting plate back until the carbide cutter mounting plate is firmly against the loader mounting plate, but **Do Not** lift the attachment off the ground.



WARNING: Before you leave the operator's seat: Lower the lift arms, put the attachment on the ground. Stop engine and remove ignition key. Engage the parking brake.

Fully lower the attachment-locking levers on the loader mounting plate.



WARNING: Locking-wedge pins must extend through the holes in attachment-mounting plate. Levers must be fully down in the locked over-center position. Failure to secure wedge pins can allow attachment to come off, causing serious injury or death.

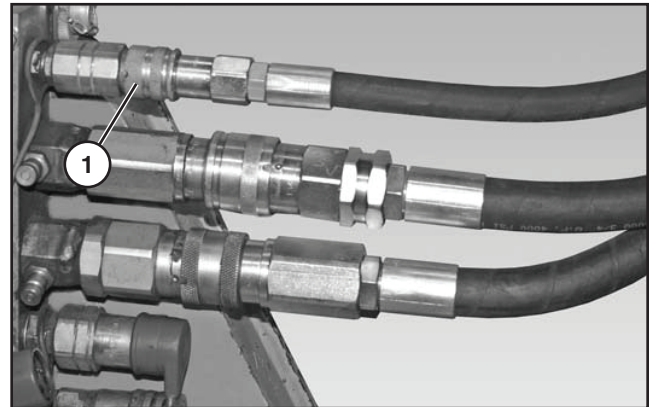

NOTE: The hydraulic hose quick couplers shown above are not supplied with the carbide cutter.

Install the carbide cutter quick couplers to the loader.

NOTE: The case drain quick coupler (1) of the carbide cutter must be connected to the loader's auxiliary hydraulic system for proper operation of the carbide cutter.

Set-up Instructions

Checking Rotor Rotation

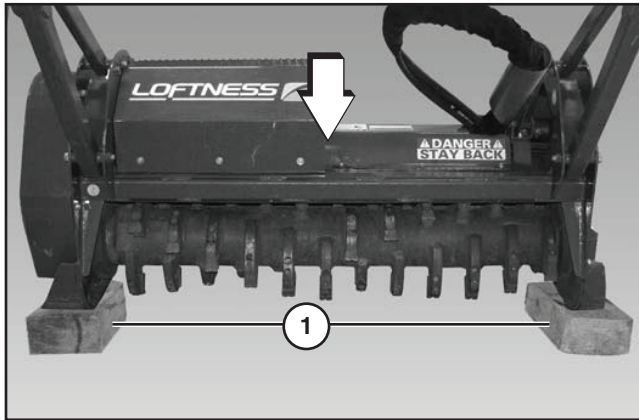

Raise the carbide cutter off the ground and place blocks (1) underneath the skids. Lower the carbide cutter down on the blocks.

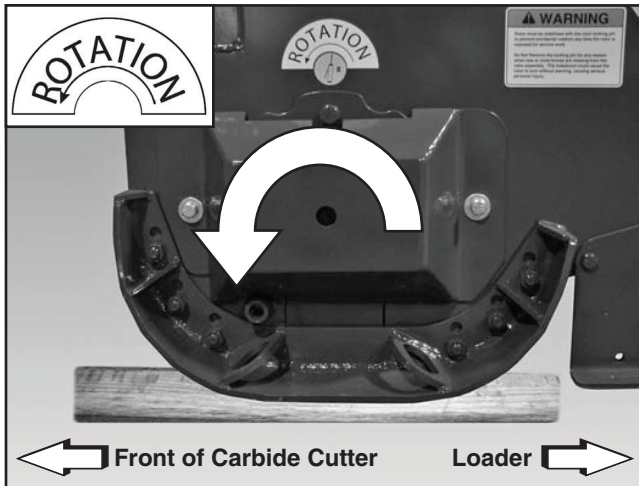

Engage the loader auxiliary hydraulics, the rotor should start rotating in forward direction. The rotation should be counterclockwise as viewed from the left side of the carbide cutter.

NOTE: If the rotor is rotating backward, reverse the quick couplers (not supplied) on the carbide cutter hydraulic hoses. Re-install the couplers (not supplied) on the loader and test for correct rotor rotation.

Checking Rotor Speed

NOTE: To order a Diagnostic Gauge Kit use # N16340.

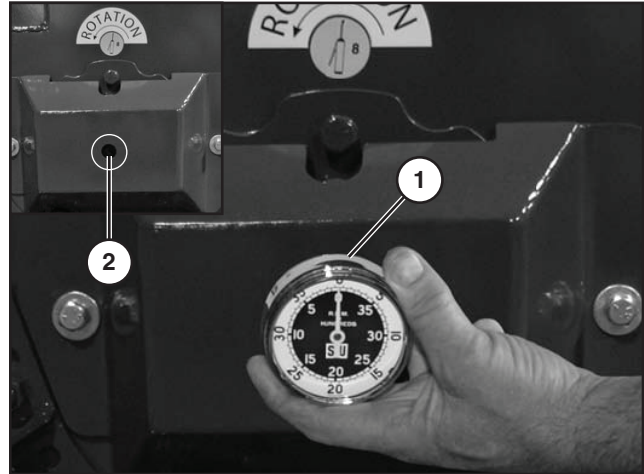

NOTE: The electronic or mechanical tachometer shown above is not supplied with the carbide cutter.

Use an electronic or mechanical tachometer (1) (access (2) thru the bearing guard) to check the rotor speed.

Test the rotor RPM with loader engine at full throttle.

See "Motor & Sheave Selection Chart" on page 25 for rotor RPM. If it is outside this recommended range, it may be necessary to disconnect the carbide cutter and test the hydraulic output of the loader with a flow meter to see if it corresponds with the factory specifications.

Pusher Bar Adjustment

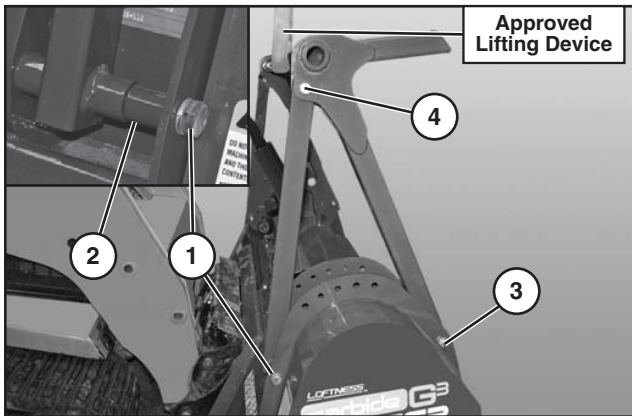

NOTE: Adjusting the pusher bar requires two people or the use of an approved lifting device to support the push bar as it is being adjusted.

Remove bolt (1) and bushing (2) from the lower storage position. Loosen the two bolts (3 & 4) to allow the pusher bar to pivot forward (on both sides).

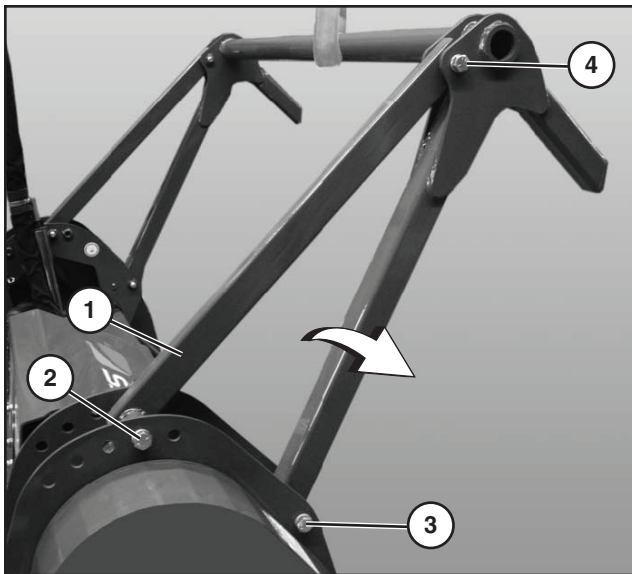

Move the pusher bar forward.

Align the rear arm (1) with the second hole from the front as shown.

Install bushing and bolt (2) and tighten securely against the frame. Tighten bolts (3 & 4).

Adjusting the Support Stands

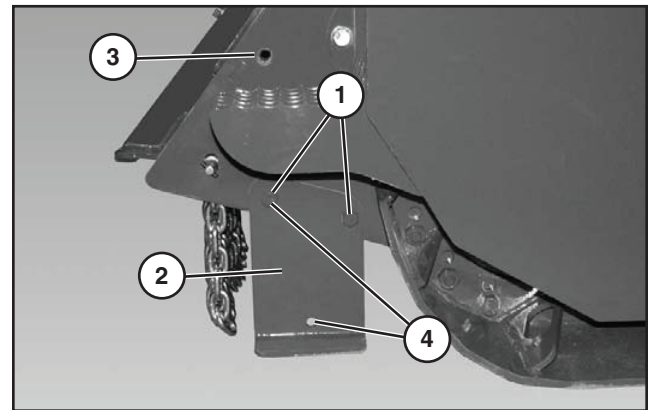

Remove the two bolts (1) and support stand (2). Repeat procedure on opposite side.

NOTE: Mounting holes (3 & 4) will be used when the support stands are in the operating position.

Move the support stand up. Install bolts (1) and tighten securely against the support stand. Repeat procedure on opposite side.

NOTE: Install the support stands in the lower position when storing the carbide cutter.

Set-up Instructions

Skid Adjustment

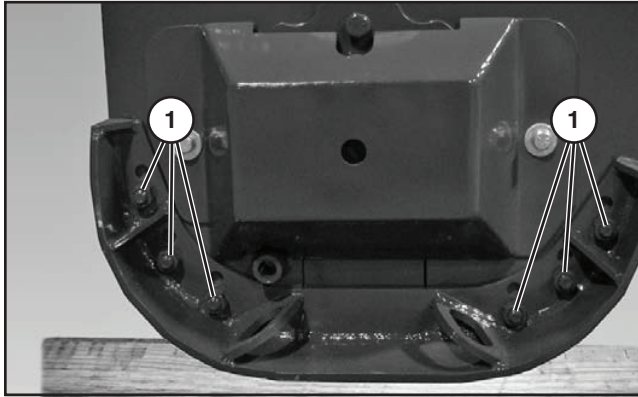

NOTE: The skid(s) can be adjusted to increase or decrease the distance between the ground and the rotor.

Remove the six nuts (1) and raise or lower the skid to the desired height. Re-install the six nuts and tighten securely against the skid.

Rotor Locking Pin Installation

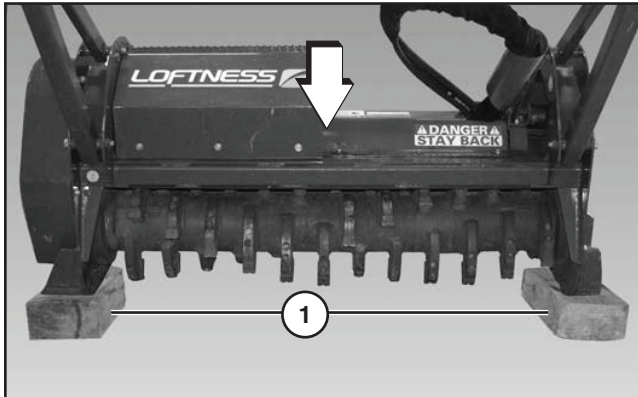

Raise the carbide cutter off the ground and place blocks (1) underneath the skids. Lower the carbide cutter down on the blocks.



WARNING: Rotor must be stabilized with rotor locking pin to prevent accidental rotation any time the rotor is exposed for service work.



WARNING: Do not remove the locking pin for any reason when one or more knives are missing from the rotor assembly. The imbalance could cause the rotor to turn without warning causing serious personal injury.

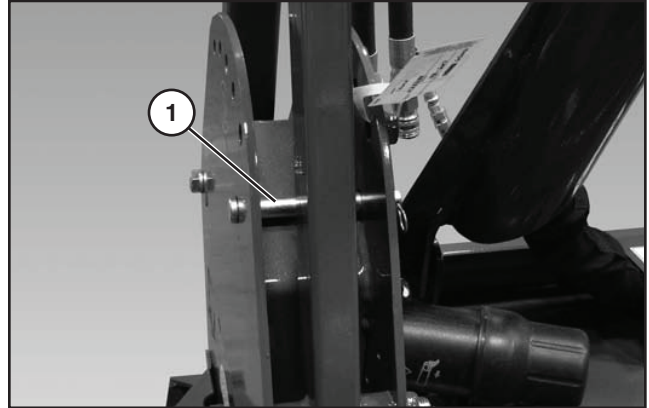

Remove the rotor lock pin (1) from the storage position.

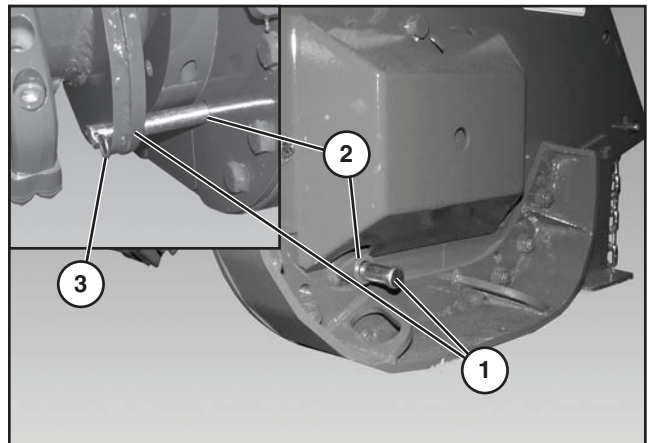

Install the rotor lock pin (1) into the opening (2) on the left side of the carbide cutter.

Align the hole in the rotor with the lock pin. Install the rotor lock pin (1) through the rotor and install the retaining pin (3).

Operating Instructions

Getting Started

For best results, the areas to be mowed should be free of debris such as bottles, metal objects, rocks and wire etc. The teeth cut and pulverize the brush, grass and weeds.

Operate the carbide cutter as low to the ground as possible without the teeth striking ground or other obstructions. Because of the high speed of the teeth, the life of the teeth will be reduced if it is operated in rocky terrain or in areas where many obstacles are present. The carbide cutter deposits cut material over the entire width-of-cut, which eliminates bunching or windrowing behind the machine.



WARNING: Due to the potential danger of flying debris, it is the owner's responsibility and is "ABSOLUTELY MANDATORY" that **IMPACT-RESISTANT SHIELDING** be installed on the machine to protect the operator.



WARNING: Lifting or tilting the carbide cutter increases the risk of flying debris.



DANGER: Keep hands and feet out! Do not step on or climb over the unit while machine is in operation, or engine is running. Do not carry passengers.



WARNING: Do not operate the attachment above the rated RPM. Check with your Loftness dealer to be sure your attachment is set-up with the correct hydraulic motor to match the hydraulic flow GPM (Gallons Per Minute) of your machine.



WARNING: Flying debris can gather on the skid-steer and needs to be cleaned off, especially around the radiator and oil cooler screens, engine compartment and exhaust areas. Periodic cleaning will help prevent the possibility of fire.



WARNING: DO NOT allow ANY people or animals within 300 feet of the work area while operating this machine.

Operation



Tilt attachment mounting frame back and raise the carbide cutter slightly above the ground when moving the carbide cutter and machine.

NOTE: Operate the carbide cutter as low to the ground as possible without the teeth striking ground or other obstructions.



WARNING: Lifting or tilting the carbide cutter increases the risk of flying debris.



WARNING: DO NOT allow ANY people or animals within 300 feet of the work area while operating this machine.

Lower the carbide cutter until the skids contact the ground. Engage the auxiliary hydraulics. Move the loader and carbide cutter forward and begin mowing.

NOTE: Various mowing conditions, and desired finished cut appearance, will determine proper ground speed.

Operating Instructions

Log Moving



Disengage the loader auxiliary hydraulics.

Raise the loader lift arms and tilt the carbide cutter forward until the push bar extensions are over the log or item being moved. Lower the lift arms and position the log between push bar extensions and the carbide cutter. Move the loader backwards, dragging the log to the desired location.

General Maintenance

To ensure efficient operation, you should inspect, lubricate, and make necessary adjustments and repairs at regular intervals. Parts that are starting to show wear should be ordered ahead of time, before a costly breakdown occurs and you have to wait for replacement parts. Keep good maintenance records, and adequately clean your carbide cutter after each use.

Proper lubrication is important. Too little lubricant will cause premature failure of a bearing. Too much lubrication usually causes high operating temperature and early failure of seals. Follow all lubrication instructions and schedules included in this section.

Maintenance Schedule

HOURS	SERVICE POINTS	SERVICE REQUIRED					
		CHECK	CLEAN	CHANGE	GREASE	ADJUST	OIL
Every 8	Machine		X				
	Loose Bolts					X	
	Hoses and Wiring	X					
	Oil Leaks	X					
	Rotor Bearing				X		
	Carbide Teeth	X					
Every 50	Belt Tensioner				X		
Every 100	Belt Tension	X					
	Drive Belt	X					
	Safety Labels	X					
Every 500	Overhung Load Adapter	X					X

Maintenance

Lubrication

Grease Point Location

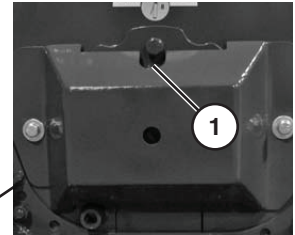

Rotor Bearing, left

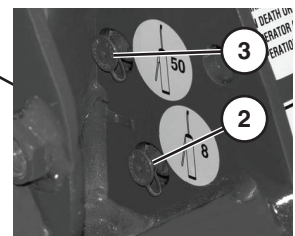

Belt Tensioner
Rotor Bearing, right

Grease Points Location (Cont'd)

Use a #2 general purpose lithium based grease unless noted otherwise.

NOTE: Replace any broken or missing grease fittings. Be sure to clean fittings before greasing.

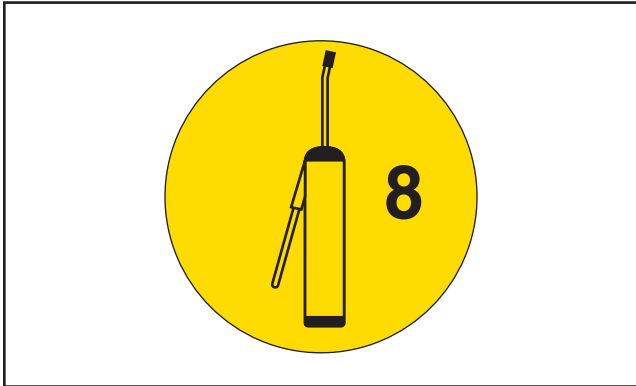

NOTE: Lubricate the grease point every "X" hours indicated on the decal adjacent to the grease point.

Numbers below after "Location" correspond to grease point locations on opposite page.

See "Carbide Cutter Identification" on page 8 for component location and identification.

• Rotor Bearings Grease Fittings

Location: (1) Left side: Located at the left side of the carbide cutter, at the top of the bearing guard

(2) Right side: Located at the base of the front push bar arm. Lubricate the fitting through the opening of the frame, (bottom grease fitting).

NOTE: Rotor bearings cannot be damaged by over-greasing. Grease fittings until a small amount of grease is purged from the bearing.

Interval: Daily or every 8 hours of operation.

• Belt Tensioner Grease Fitting

Location: (3) - Located at the base of the front push bar arm, right side. Lubricate the fitting through the opening of the frame, (top grease fitting).

NOTE: Remove the belt cover when lubricating the fitting. Visually inspect the idler pulley components while lubricating. Do Not over lubricate the idler tensioner shaft.

NOTE: Over lubricating may be transferred to the belt, causing the belt to slip, resulting in loss of rotor RPM speed and loss of power to the rotor.

Interval: Every 50 hours of operation.

Overhung Load Adapter

NOTE: If replacing bearings or seals in the overhung load adapter, be certain to refill with 6 oz. of hydraulic fluid after reassembly.

Maintenance

Belt Adjustment

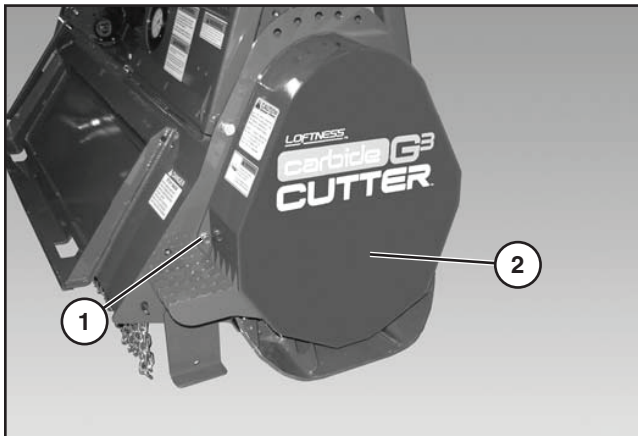

Remove the six bolts (1) and drive belt cover (2).

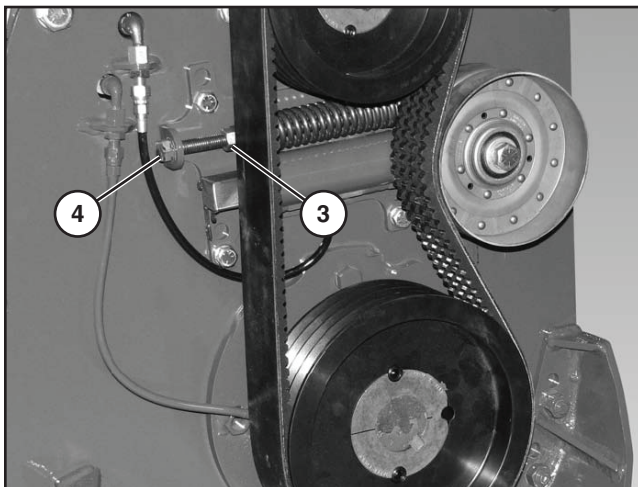
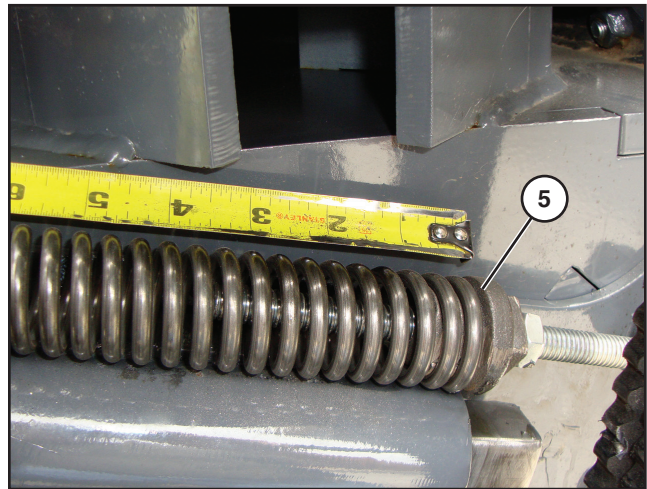

Loosen jam nut (3).

Turn adjustment bolt (4) clockwise to increase spring tension.

Turn adjustment bolt (4) counterclockwise to decrease spring tension when replacing drive belt.

Remove the belt while belt tension is released.

NOTE: When replacing or installing a new belt, align the grooves in the belt with the upper and lower pulleys.



Turn the adjustment bolt clockwise until the distance from the collar (5) to the end of the spring (6) is approximately 10 - 1/4". Tighten jam nut (5).

Tooth Removal and Installation

Double Tooth & Double Planer

Install the rotor locking pin. See “Rotor Locking Pin Installation” on page 16.

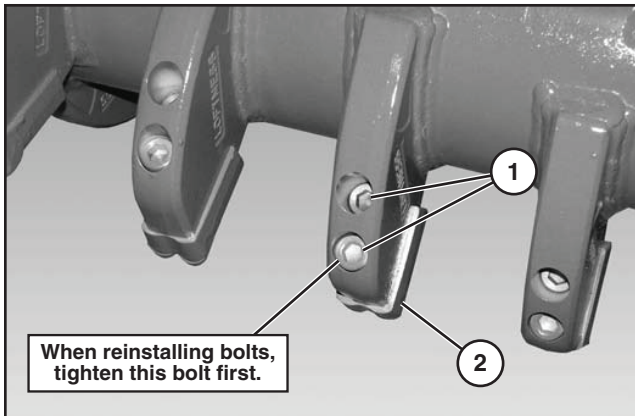

Remove the two bolts (1) and tooth (2).

Use copper based anti-seize when reinstalling the bolts. Torque to 137 ft.-lbs.

IMPORTANT: Tighten the bolt on the top edge of the tooth first when reinstalling.

Quadco Teeth

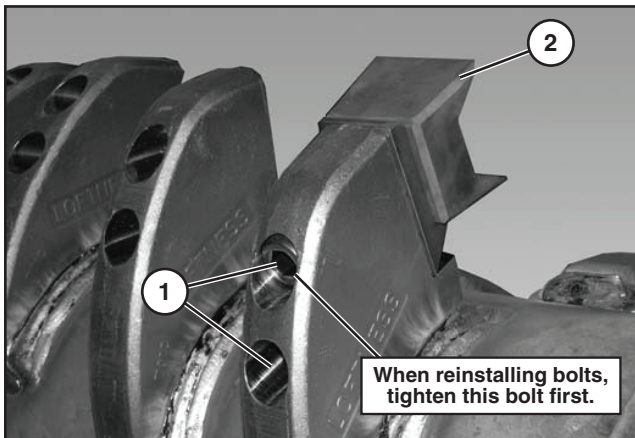

Remove the two bolts (1) and tooth (2).

Use copper based anti-seize when reinstalling the bolts. Torque to 137 ft.-lbs.

IMPORTANT: Tighten the bolt on the top edge of the tooth first when reinstalling.

Tooth Sharpening (Quadco Option Only)

NOTE: The teeth need to be kept sharp to maintain the most effective operation of the attachment. Daily inspection and touch up is recommended.

NOTE: The teeth can either be removed from the attachment or remain installed for sharpening.

Install the rotor locking pin. See “Rotor Locking Pin Installation” on page 16.



WARNING: Rotor must be stabilized with rotor locking pin to prevent accidental rotation any time the rotor is exposed for service work.



WARNING: Do not remove the locking pin for any reason when one or more teeth are missing from the rotor assembly. The imbalance could cause the rotor to turn without warning causing serious personal injury.

Note: Guard on grinder removed for photo clarity.

Leading Edge

NOTE: The Quadco cutter teeth have been heat treated to a specific hardness. Care must be taken to avoid overheating the leading edge of the tooth while sharpening. If the coloring in the tooth changes to either a blue or brown during the sharpening, you have removed the temper and the tooth will not hold it's cutting edge.

NOTE: When re-sharpening teeth using machine shop equipment, avoid overheating the teeth by using a flood coolant system.

Maintenance

Tooth Sharpening (Quadco Option Only) - Cont'd

NOTE: When re-sharpening teeth using a hand grinder, avoid overheating the tooth by lightly grinding each tooth, moving across the entire row of teeth before returning to the first tooth to repeat the procedure.

NOTE: Sharpen each tooth equally to maintain rotor balance. Always return tooth to its original location if it is removed from the rotor for sharpening.

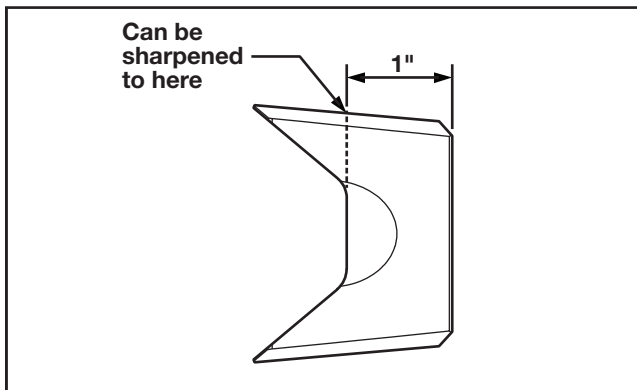

NOTE: Tooth can be sharpened to distance shown in illustration above.

NOTE: When re-sharpening teeth using a hand grinder, avoid overheating the tooth by lightly grinding each tooth, moving across the entire row of teeth before returning to the first tooth to repeat the procedure.

NOTE: Sharpen each tooth equally to maintain rotor balance. Always return tooth to its original location if it is removed from the rotor for sharpening.

Storage

End of Season

- Clean entire carbide cutter thoroughly.
- Clean belt and pulleys, relax the belt tension.
- Lubricate all parts of the machine. See "Lubrication" on page 20.
- Make a list of all worn or damaged parts and replace them.
- Paint all parts that are worn or rusted.
- Store carbide cutter in a clean, dry area.
- Review the carbide cutter operator's manual.

Beginning of the Season

- Review the carbide cutter operator's manual.
- Lubricate all parts of the machine. See "Lubrication" on page 20.
- Tighten all bolts, nuts, and set screws. See "Torque Specifications" on page 61.
- Adjust belt tension. See "Belt Adjustment" on page 22.
- Replace all damaged, worn or missing decals.
- Install the carbide cutter on a loader and test the carbide cutter for proper operation.



WARNING: *DO NOT* allow *ANY* people or animals within 300 feet of the work area while operating this machine

Motor & Sheave Selection Chart

GPM	VARIABLE DISPLACEMENT MOTOR NUMBER	DISPLACEMENT	LOFTNESS PART NUMBER	ROTOR RPM	TOP SHEAVE (LOFTNESS NUMBER) BOTTOM SHEAVE (LOFTNESS NUMBER) BELT LENGTH (LOFTNESS NUMBER)
31	33	60cc - 80cc (3.66ci - 4.89ci)	N28205	1762-1321	9.0 Top Sheave (N20806) 9.75 Bottom Sheave (N18974) 63" 4B5V Belt (N28703) Model Code "J"
32				1819-1364	
33				1875-1406	
34				1932-1449	
35				1989-1491	
36				2046-1534	
37				2102-1577	
38	33	60cc - 80cc (3.66ci - 4.89ci)	N28205	2048-1536	8.5 Top Sheave (N20810) 9.75 Bottom Sheave (N18974) 63" 4B5V Belt (N28703) Model Code "F"
39				2102-1576	
40				2156-1617	
41	33	60cc - 80cc (3.66ci - 4.89ci)	N28205	1967-1477	8.0 Top Sheave (N20809) 10.3 Bottom Sheave (N20811) 63" 4B5V Belt (N28703) Model Code "H"
42				2017-1513	

GPM	FIXED DISPLACEMENT MOTOR NUMBER	DISPLACEMENT	LOFTNESS PART NUMBER	ROTOR RPM	TOP SHEAVE (LOFTNESS NUMBER) BOTTOM SHEAVE (LOFTNESS NUMBER) BELT LENGTH (LOFTNESS NUMBER)
31	30	60cc (3.66ci)	N20840	1762	9.0 Top Sheave (N20806) 9.75 Bottom Sheave (N18974) 63" 4B5V Belt (N28703) Model Code "J"
32				1819	
33				1875	
34				1932	
35				1989	
36				2046	
37	30	60cc (3.66ci)	N20840	1777	8.0 Top Sheave (N20809) 10.3 Bottom Sheave (N20811) 63" 4B5V Belt (N28703) Model Code "H"
38				1824	
39				1873	
40				1921	
41				1969	
42				2017	

LOADER HYDRAULIC SYSTEM PRESSURE FIXED DISPLACEMENT	SETTING NUMBER	MOTOR THRESHOLD SETTING
FIXED DISP ALL psi	0	N/A

LOADER HYDRAULIC SYSTEM PRESSURE VARIABLE MOTORS	SETTING NUMBER	MOTOR THRESHOLD SETTING
2800psi - 3400psi	1	2175
3400psi - 3800psi	2	2900
3800psi - 4200psi	3	3400

NOTE: Consult factory for instructions to change threshold setting.

Maintenance

Troubleshooting

PROBLEM	CAUSE	SOLUTION
Excessive Vibration	Broken or missing teeth.	Replace teeth.
	Mud and/or debris wrapped around the rotor.	Clean the carbide cutter.
	Faulty drive line bearing.	Replace bearing(s).
	Faulty rotor bearing.	Replace bearing(s).
	Damage to rotor (includes bent end of shafts, missing balance weights, or actual rotor deformity from striking rocks, etc.)	Consult factory.
Uneven Cutting	Teeth dull or worn excessively.	Replace teeth.
	Engine RPM too slow.	Adjust machine RPM to full throttle.
	Travel speed too fast.	Reduce ground speed.
Rotor Will Not Turn	Faulty drive line bearing.	Replace bearing(s).
	Faulty rotor bearing.	Replace bearing(s).
	Belt damaged.	Replace belt.
	Belt slipping.	Clean or replace belt. Adjust tension.



PARTS IDENTIFICATION

Parts Identification

Carbide Cutter Drive Assembly

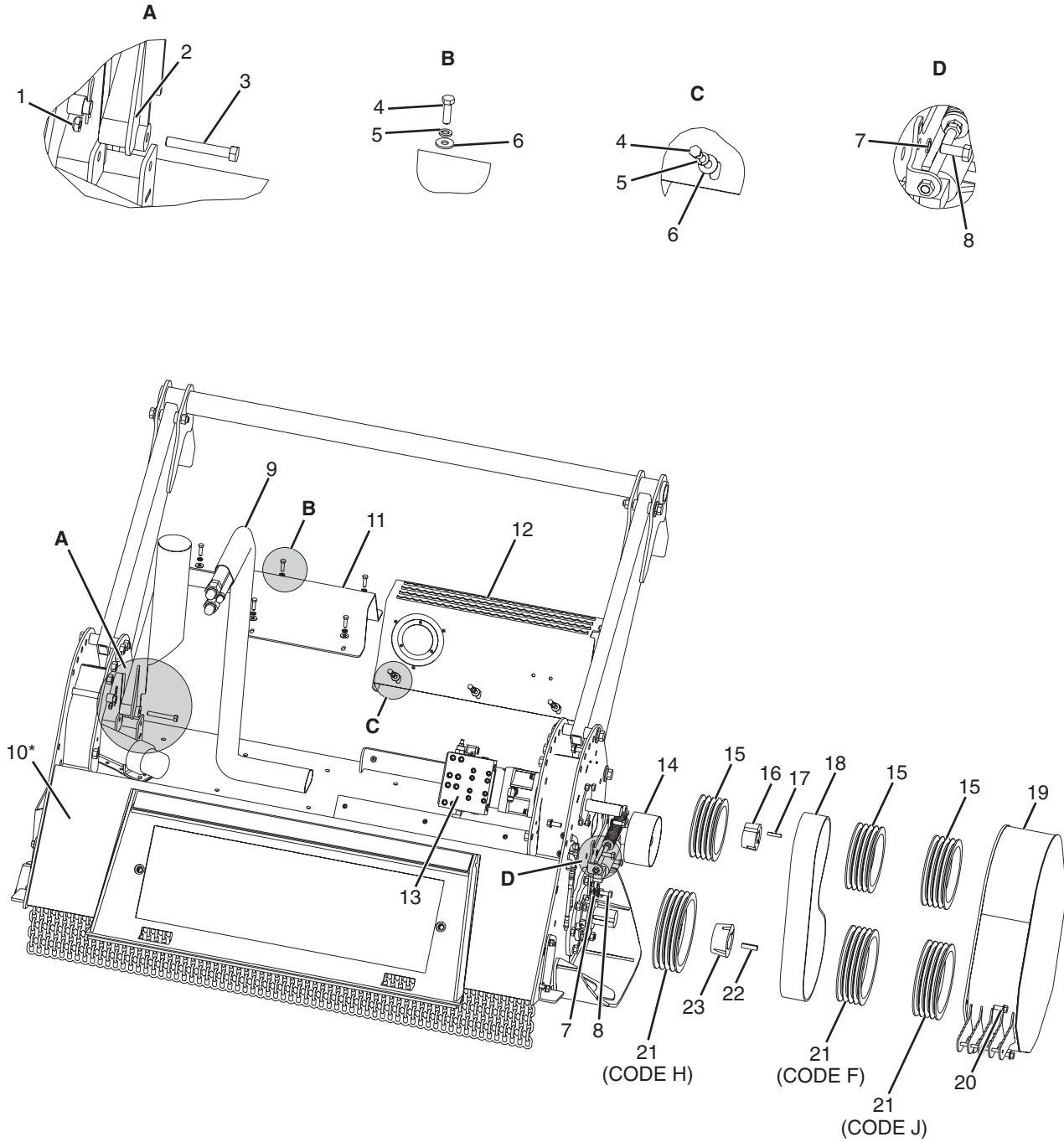

* - Item 10 is not a replacement part.

Parts Identification

Carbide Cutter Drive Assembly

#	QTY.	PART #	DESCRIPTION
1	1	4054	NUT, LOCK 1/2" TOP
2	1	N28333	HOLDER, HOSE WELDMENT
3	1	4154	BOLT, 1/2" X 3 - 1/2" GRADE 5
4	11	4005	BOLT, 3/8" x 1 - 1/4" GRADE 5
5	11	4065	WASHER, 3/8" LOCK
6	11	4064	WASHER, FLAT 3/8"
7	4	N16472	WASHER, 1/2" NORDLOCK
8	4	4012	BOLT, 1/2" x 1-1/4" GRADE 5
9	1	N28471	KIT, HOSE CCH 1" x 126" & 144"
10 <i>Not a replacement part.</i>	1		CARBIDE, 51" CARBIDE W / STD CUTTERS
	1		CARBIDE, 61" CARBIDE W / STD CUTTERS
	1		CARBIDE, 71" CARBIDE W / STD CUTTERS
11	1	N28406	PLATE, CARBIDE 51" HOSE SHIELD
	1	N28354	PLATE, CARBIDE 61" HOSE SHIELD
	1	N28407	PLATE, CARBIDE 71" HOSE SHIELD
12	1	N15974	SHIELD, CARB MTR W / GAUGE
13	1	N28409	MOTOR ASSY, #530 OPEN
	1	N28410	MOTOR ASSY, #630 CLOSED
	1	N28472	MOTOR ASSY, #933 OPEN 15 BAR
14	1	N28018	TENSIONER, BELT 4 BAND
15	1	N20810	SHEAVE, 4/5V x 8.50 - 2517 (MODEL CODE "F")
	1	N20809	SHEAVE, 4/5V x 8.00 - 2517 (MODEL CODE "H")
	1	N20806	SHEAVE, 4/5V x 9.00 - 2517 (MODEL CODE "J")
16	1	8126	BUSHING, 1 - 1/2" TAPERLOCK KEYED
17	1	7121 - 02	KEY, 3/8" x 1 - 3/4"
18	1	N28703	BELT, 4/5V x 63 GATES
19	1	N20004	SHIELD, CARBIDE BELT
20	6	N18360	BOLT, 1/2" x 1 - 1/4" SERATED FLANGE
21	1	N18974	SHEAVE, 4/5V x 9.75 - 3020 (MODEL CODE "F")
	1	N20811	SHEAVE, 4/5V x 10.30 - 3020 (MODEL CODE "H")
	1	N18974	SHEAVE, 4/5V x 9.75 - 3020 (MODEL CODE "J")
22	1	7122 - 04	KEY, 1/2" x 2"
23	1	N18975	BUSHING, 2 - 3/16" TPL 1/2" KEY 117121

Parts Identification

Carbide Cutter Body Assembly

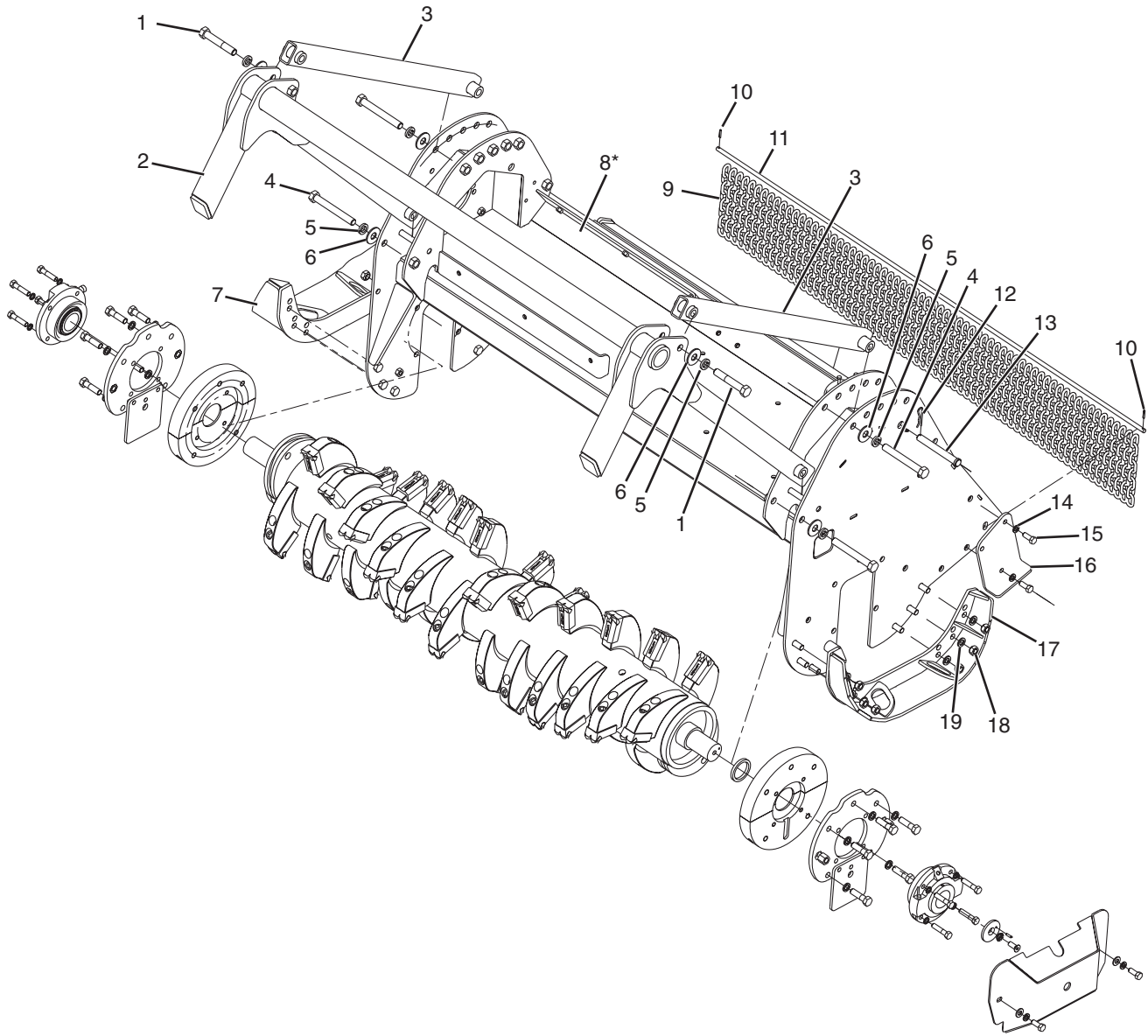

* - Item 8 is not a replacement part.

Parts Identification

Carbide Cutter Body Assembly

#	QTY.	PART #	DESCRIPTION
1	2	4244	BOLT, 3/4" x 4 - 1/2" GRADE 5
2	1	N21094	PUSHER, 51" CARBIDE
	1	N20100	PUSHER, 61" CARBIDE
	1	N20167	PUSHER, 71" CARBIDE
3	2	N19048	ARM, CARBIDE PUSHER MECHANICAL
4	4	4029	BOLT, 3/4" x 6" GRADE 5
5	6	4287	WASHER, 3/4" LOCK
6	6	4071	WASHER, 3/4" FLAT
7	1	N15989	SKID, CARBIDE RIGHT
8 <i>Not a replacement part.</i>	1		BODY, 51" CARBIDE
	1		BODY, 61" CARBIDE
	1		BODY, 71" CARBIDE
9	56	N15589	CHAIN, CARBIDE REAR 51"
	66	N15589	CHAIN, CARBIDE REAR 61"
	76	N15589	CHAIN, CARBIDE REAR 71"
10	2	4375	PIN, ROLL 3/16" x 1"
11	1	N20062	ROD, CARBIDE 51" CHAIN
	1	N20102	ROD, CARBIDE 61" CHAIN
	1	N20166	ROD, CARBIDE 71" CHAIN
12	1	4336	CLIP, HAIRPIN 1/8" x 2 - 1/4"
13	1	N15995	PIN, 3/4" x 5 - 3/4"
14	4	4155	WASHER, LOCK 1/2"
15	4	4012	BOLT, 1/2" x 1 - 1/4" GRADE 5
16	1	N20579	STAND, CARBIDE SHIPPING LEFT
17	1	N15987	SKID, CARBIDE LEFT
18	12	4055	NUT, LOCK 5/8" TOP
19	12	4070	WASHER, LOCK 5/8"

Parts Identification

Carbide Cutter Body Assembly (Cont'd)

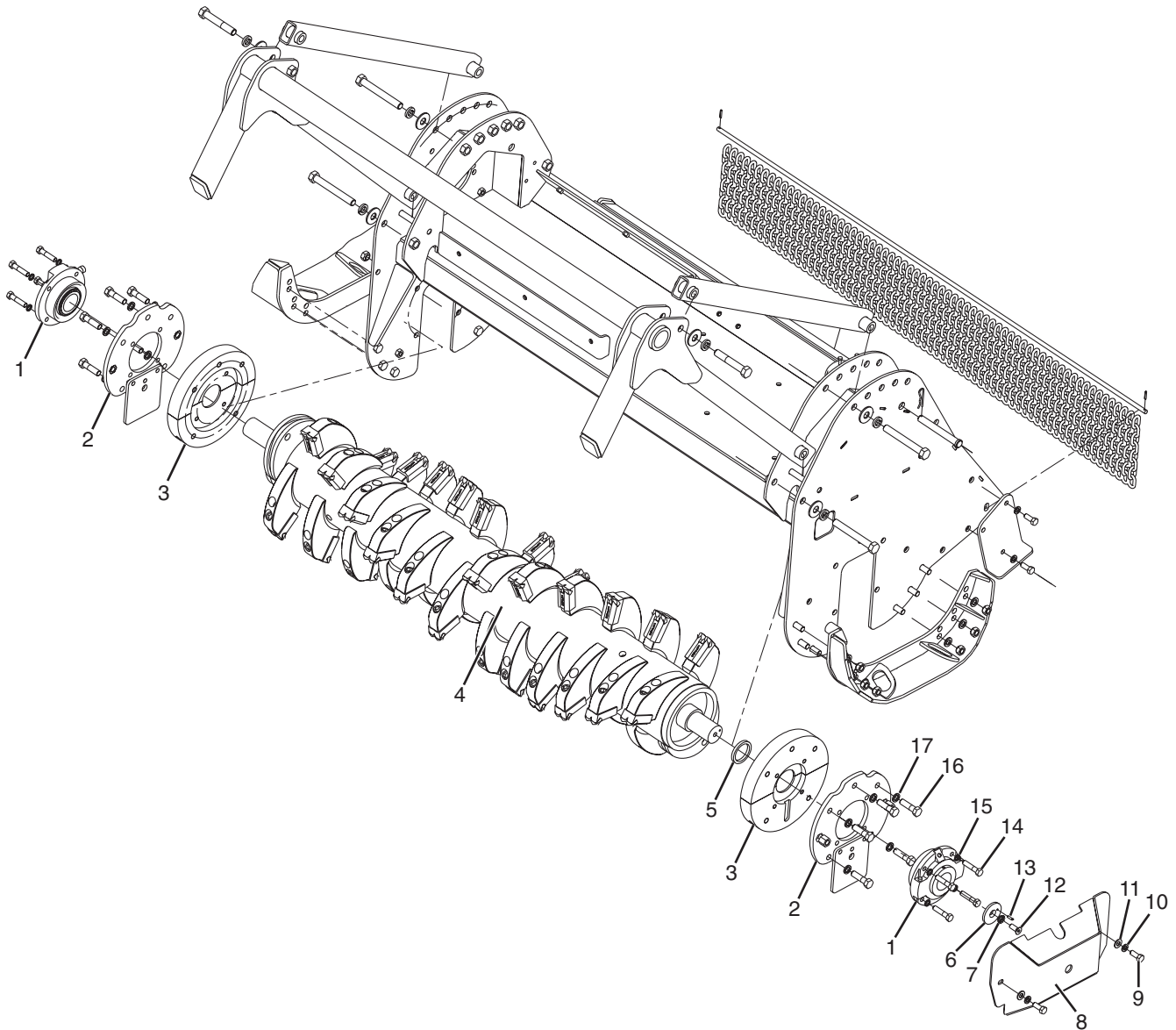

Parts Identification

Carbide Cutter Body Assembly (Cont'd)

#	QTY.	PART #	DESCRIPTION
1	2	N16417	BEARING, 2 - 3/16" PILOT ROLLER
2	2	N20059	MOUNT, CARBIDE ROTOR BEARING
3	2	N18929	ANTIWRAP, CARBIDE MACHINED 2 - PIECE
4	1	N20083	ROTOR, 51" CARBIDE WITH DOUBLE CUTTERS
	1	N20077	ROTOR, 61" CARBIDE WITH DOUBLE CUTTERS
	1	N20080	ROTOR, 71" CARBIDE WITH DOUBLE CUTTERS
5	1	N16445	BUSHING, 2 - 3/16" ID x 2 - 3/4" OD
6	1	4075	WASHER, 2 - 5/8" OD BEARING RETAINER
7	1	4076	WASHER, 1/2" EXT CNTSK LOCK
8	1	N20012	GUARD, BEARING WELDED
9	2	4012	BOLT, 1/2" x 1 - 1/4" GRADE 5
10	2	4155	WASHER, LOCK 1/2"
11	2	4068	WASHER, 1/2" SAE FLAT
12	1	4468	SCREW, 1/2" x 20UNF x 1 1/4" FN TD FL HD CAP
13	1	4085	PIN, ROLL 3/16" x 3/4"
14	8	N20043	BOLT, 1/2" x 2 - 1/4" FN TD GR 8
15	8	N16472	WASHER, 1/2" NORDLOCK
16	10	4494	BOLT, 5/8" x 2 - 1/4" GRADE 8 FINE THREAD
17	10	N16473	WASHER, 5/8" NORDLOCK

Parts Identification

Carbide Cutter Body Assembly (Cont'd)

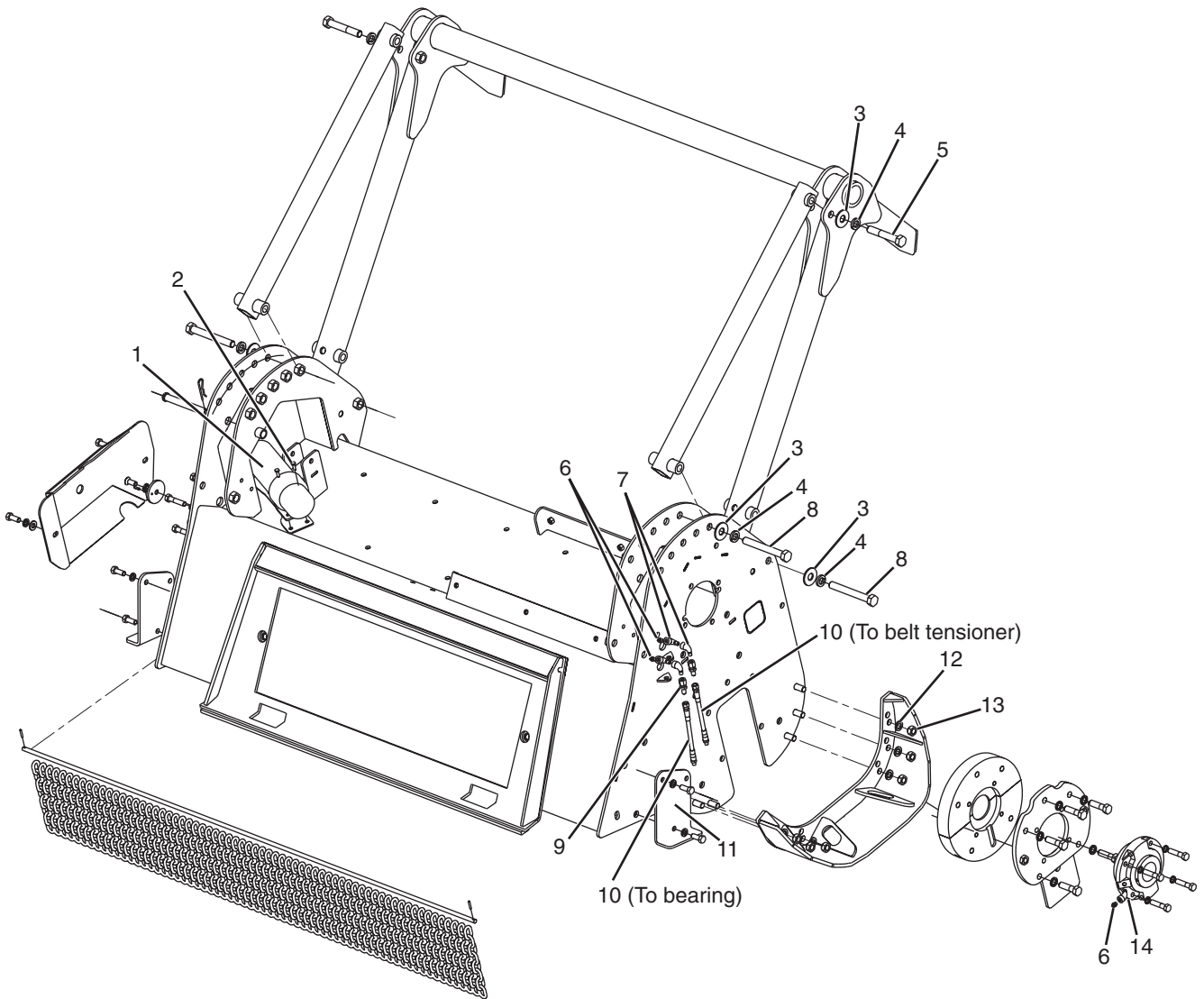

Carbide Cutter Body Assembly (Cont'd)

#	QTY.	PART #	DESCRIPTION
1	1	N19600	HOLDER, MANUAL
2	3	4340	BOLT, 1/4" x 3/4" GRADE 5
3	6	4071	WASHER, 3/4" FLAT
4	6	4287	WASHER, 3/4" LOCK
5	2	4244	BOLT, 3/4" x 4 - 1/2" BOLT GR 5
6	2	N17007	GREASE - ZERK, 1/8 NPT
7	4	4472	ELBOW, 1/8" 90 DEG. STREET
8	4	4029	BOLT, 3/4" x 6" GRADE 5
9	2	4304 - 10	BULKHEAD. FITTING - GREASE HOSE
10	2	4304	HOSE, 15" GREASE W / FITTINGS
11	1	N20572	STAND, CARBIDE SHIPPING RIGHT
12	12	4070	WASHER, LOCK 5/8"
13	12	4055	NUT, LOCK 5/8" TOP
14	1	4471	ELBOW, 1/8" 45 DEG. STREET

Parts Identification

Motor Assembly #530 Open (N28409)

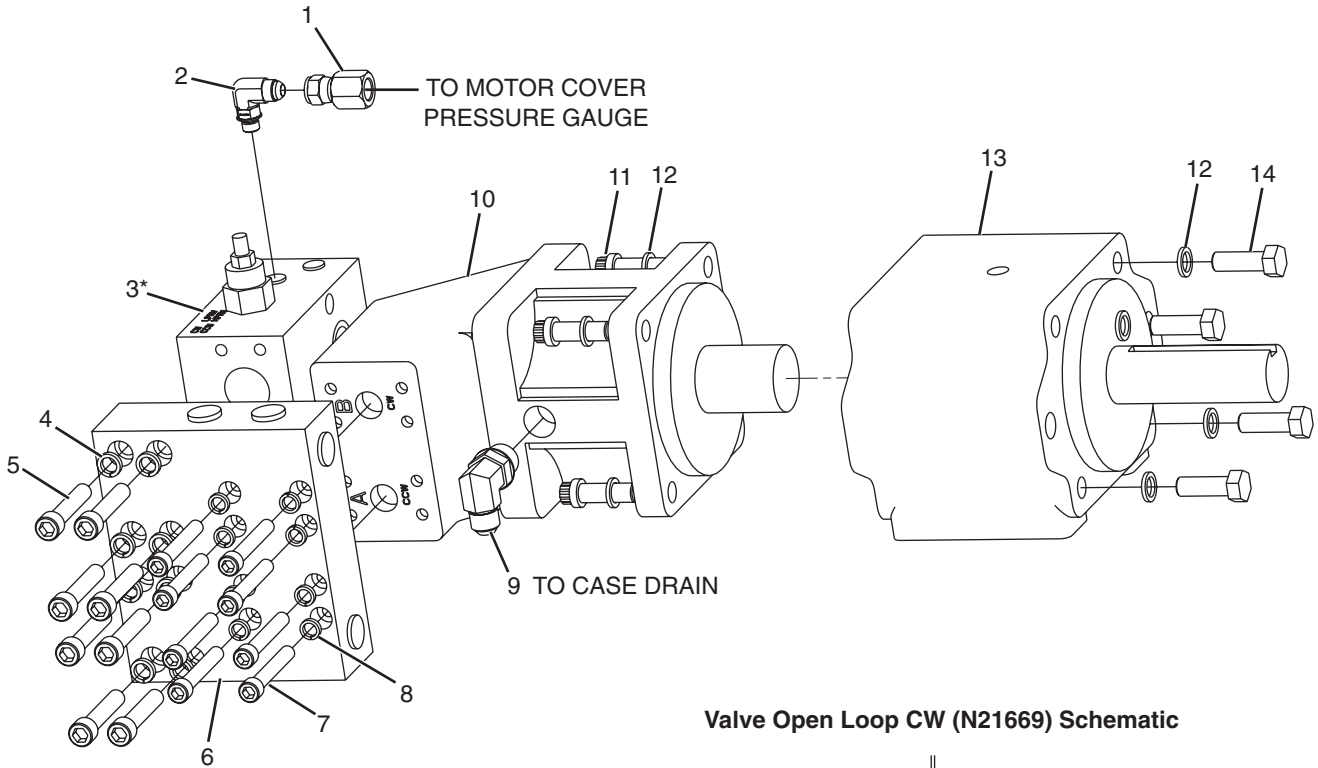

* Item 3 (N21669) parts breakdown.

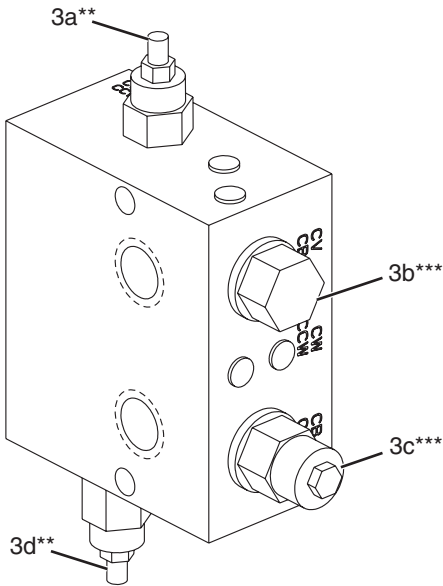

** Use item 15 in parts list, part number N38181, for seal kit for items 3a and 3d.

*** Use item 16 in parts list, part number N14170, for seal kit for items 3b and 3c.

Valve Open Loop CW (N21669) Schematic

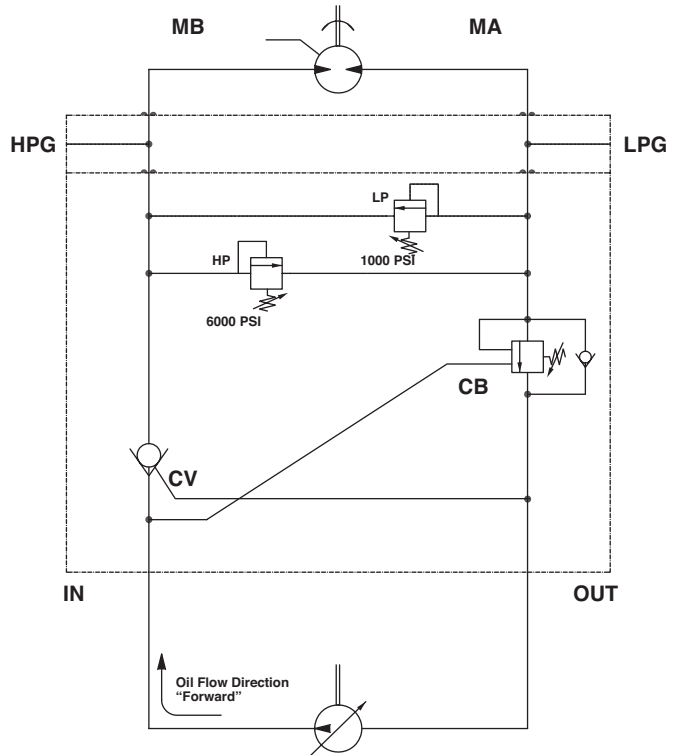

Parts Identification

Motor Assembly #530 Open (N28409)

#	QTY.	PART #	DESCRIPTION
1	1	N28893	ADAPTER, - 6FJIC - 6FP
2	1	N28907	ELBOW, 90DEG - 6MJIC - 4MOR
3	1	N21669	VALVE, OPEN LOOP CW
3a	1	N28100**	RELIEF, LOW PRESSURE 1000PSI
3b	1	N28102***	VALVE, CHECK PILOT OPERATED
3c	1	N28103***	VALVE, COUNTERBALANCE
3d	1	N28099**	RELIEF, HIGH PRESSURE 5000PSI
4	8	N21917	WASHER, HIGH COLLARLOCK 7/16"
5	8	N21915	BOLT, SHCS 7/16" x 2 - 1/4" GRADE 5
6	1	N20976	BLOCK, VALVE
7	8	N21914	BOLT, SHCS 3/8" x 2 - 1/2" GRADE 5
8	8	N21916	WASHER, HIGH COLLARLOCK 3/8"
9	1	N16173	ELBOW, 90 DEG - 8 MJC - 10 MOR
10	1	N20840	MOTOR, VOAC 60
11	4	N28502	BOLT, 1/2" x 1 - 1/2" 12 PT GRADE 8
12	8	N16472	WASHER, 1/2" NORDLOCK
13	1	N20901	ADAPTER, 900 SER LOAD 4.5 SHAFT
14	4	4013	BOLT, 1/2" x 1 - 1/2" GRADE 5
15	1	N38181	KIT, SEAL CART SUN RDFA-LCN
16	1	N14170	KIT, COUNTER BALANCE SEAL

** Use item 15, part number N38181, for seal kit for valves N28099 and N28100.

*** Use item 16, part number N14170, for seal kit for valves N28102 and N28103.

Parts Identification

Motor Assembly #630 Closed (N28410)

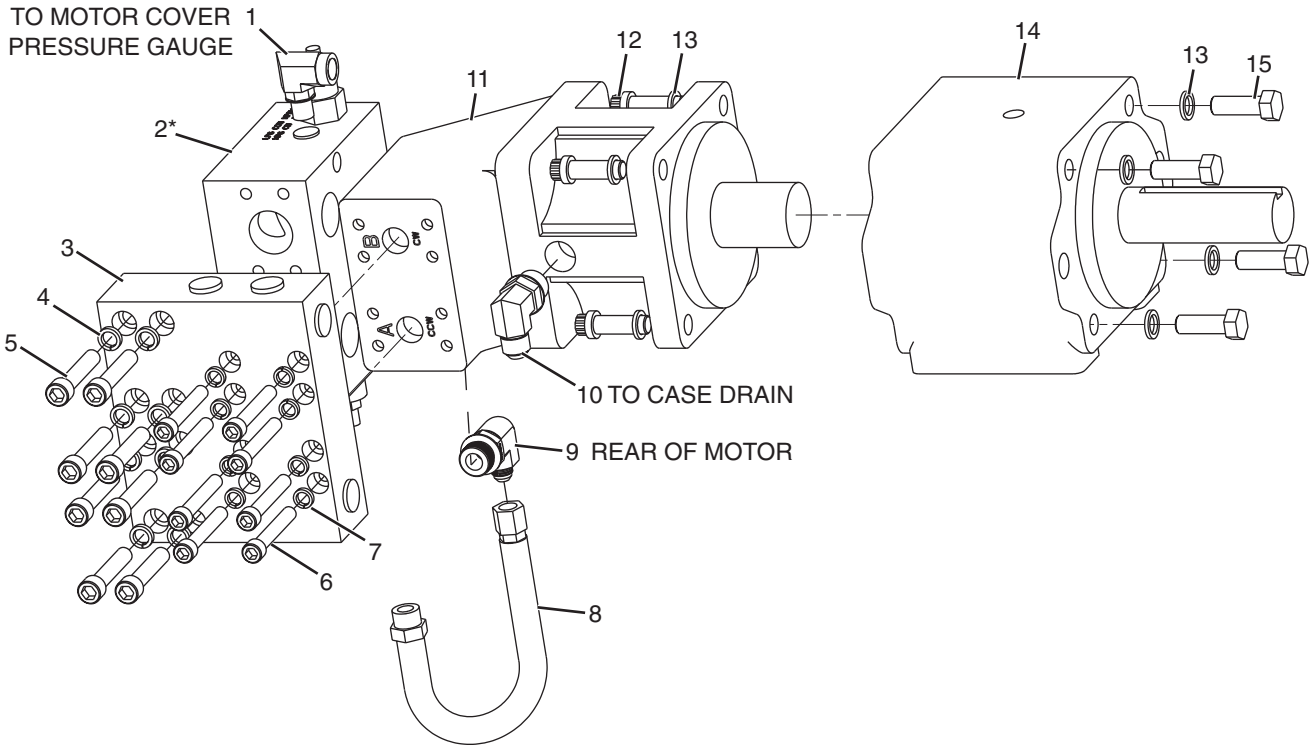

Relief Valve Closed Loop CW (N23026) Schematic

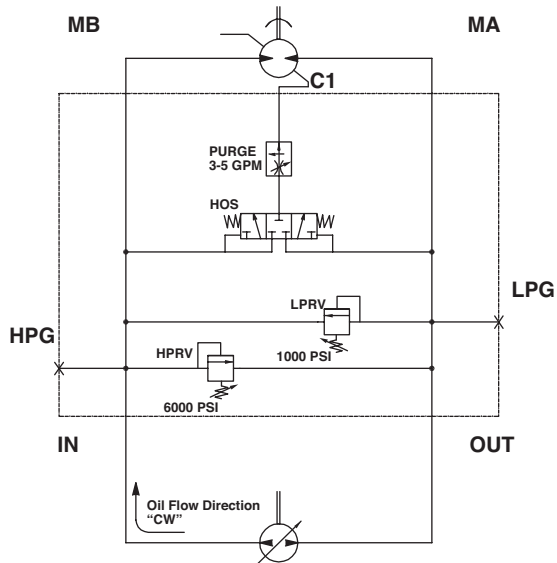

* Item 2 (N23026) parts breakdown.

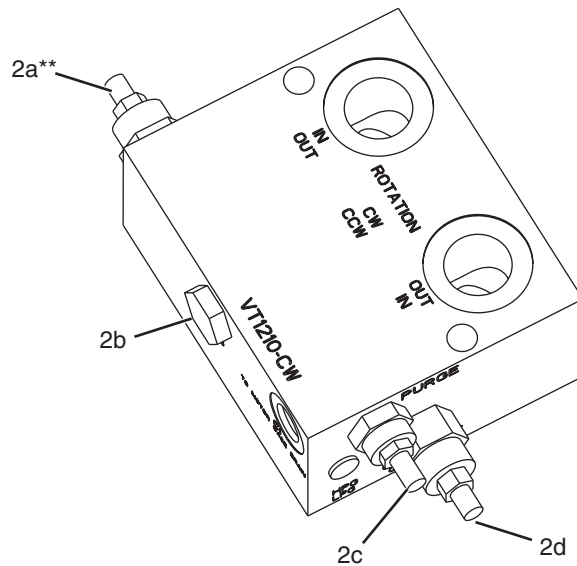

** Use item 16 in parts list, part number N38181, for seal kit for items 2a and 2d.

Parts Identification

Motor Assembly #630 Closed (N28410)

#	QTY.	PART #	DESCRIPTION
1	1	N16066	ELBOW, - 6 MOR - 6FP / 90 DEG
2	1	N23026	VALVE, RELIEF CLOSED LOOP CW
2a	1	N28100**	VALVE, RELIEF LOW PRESSURE 1000PSI
2b	1	N28101	VALVE, HOT OIL SHUTTLE
2c	1	N28098	VALVE, PURGE FLOW CONTROL
2d	1	N28099**	VALVE, RELIEF HIGH PRESSURE 5000PSI
3	1	N20976	BLOCK, VALVE
4	8	N21917	WASHER, HIGH COLLARLOCK 7/16"
5	8	N21915	BOLT, SHCS 7/16" x 2 - 1/4" GRADE 5
6	8	N21914	BOLT, SHCS 3/8" x 2 - 1/2" GRADE 5
7	8	N21916	WASHER, HIGH COLLARLOCK 3/8"
8	1	N16166	HOSE, 3/8" x 24" - 6 FJIC - 8 MOR
9	1	N21992	ELBOW, 90 DEG - 6 MJIC - 10 MOR
10	1	N16173	ELBOW, 90 DEG - 8 MJC - 10 MOR
11	1	N20840	MOTOR, VOAC 60
12	4	N28502	BOLT, 1/2" x 1 - 1/2" 12 PT GRADE 8
13	8	N16472	WASHER, 1/2" NORDLOCK
14	1	N20901	ADAPTER, 900 SER LOAD 4.5 SHAFT
15	4	4013	BOLT, 1/2" x 1 - 1/2" GRADE 5
16	1	N38181	KIT, SEAL CART SUN RDFA-LCN

** Use item 16, part number N38181, for seal kit for valves N28099 and N28100.

Parts Identification

Motor Assembly #933 Open 15 Bar (N28472)

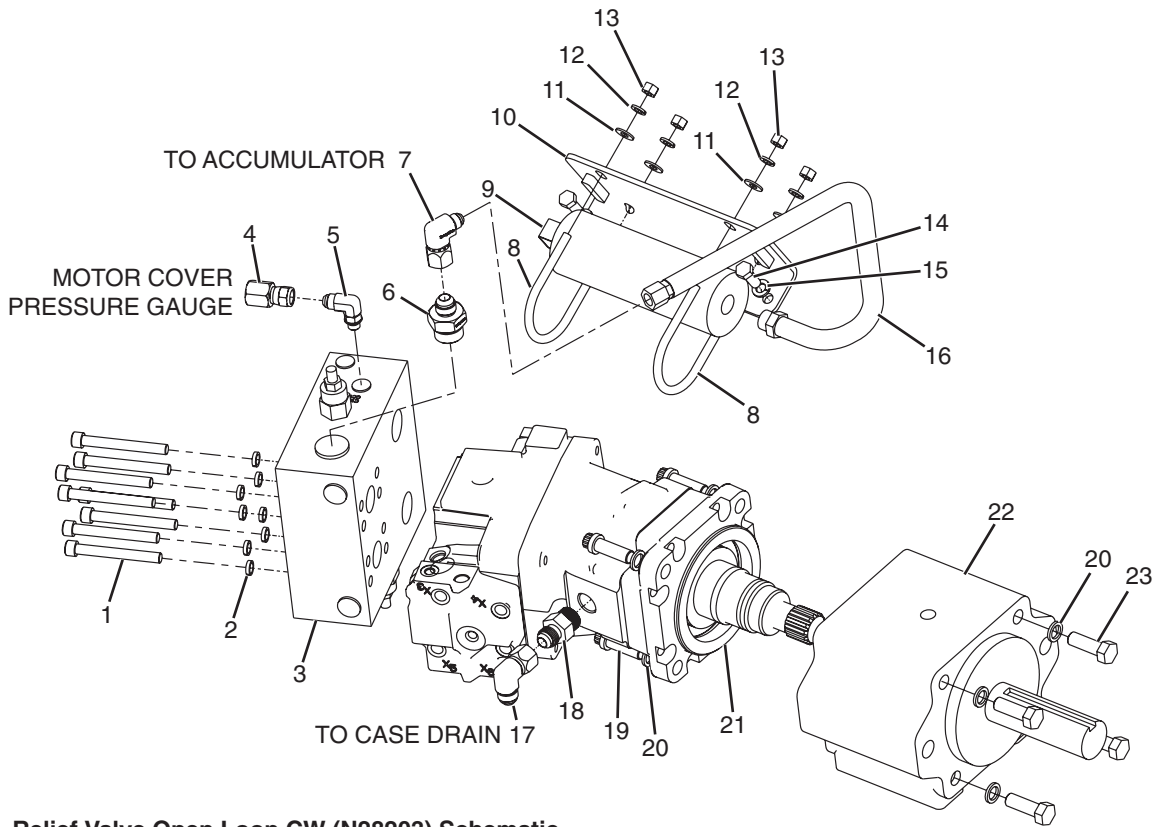

Relief Valve Open Loop CW (N28203) Schematic

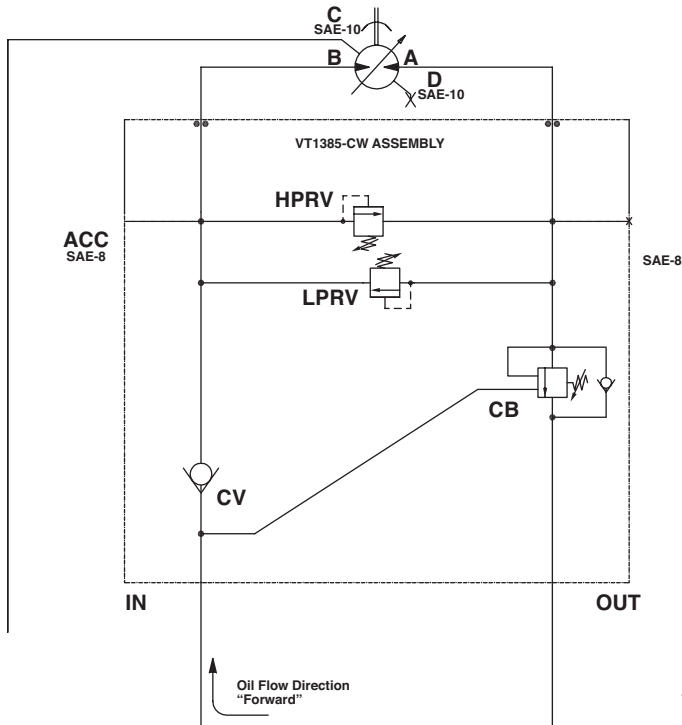

* Item 3 (N28203) parts breakdown.

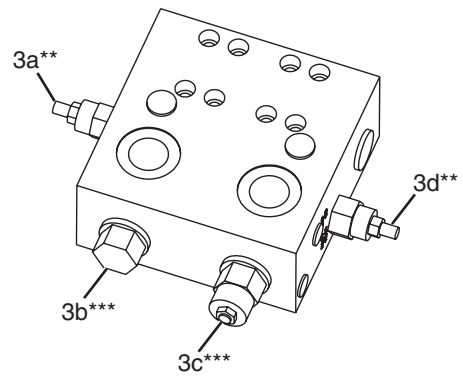

** Use item 24 in parts list, part number N38181, for seal kit for items 3a and 3d.

*** Use item 25 in parts list, part number N14170, for seal kit for items 3b and 3c.

Parts Identification

Motor Assembly #933 Open 15 Bar (N28472)

#	QTY.	PART #	DESCRIPTION
1	8	N28353	BOLT, SHCS 3/8" x 3 - 1/4"
2	8	N21916	WASHER, HIGH COLLARLOCK 3/8"
3	1	N28203	VALVE, RELIEF OPEN LOOP CW
3a	1	N28100**	VALVE, RELIEF LOW PRESSURE 1000PSI
3b	1	N28102***	VALVE, CHECK PILOT OPERATED
3c	1	N28103***	VALVE, COUNTERBALANCE
3d	1	N28099**	VALVE, RELIEF HIGH PRESSURE 5000PSI
4	1	N28893	ADAPTER, - 6FJIC - 6FP
5	1	N28907	ELBOW, 90DEG - 6MJIC -4MOR
6	1	N29731	ADAPTER, - 8MJIC - 12MOR
7	1	N19068	ELBOW, 90 DEG - 6MJIC - 8FJIC
8	2	N16125	U - BOLT, 5/16" x 2 - 1/2" x 3 - 1/2"
9	1	N16074	ACCUMULATOR, 500 PSI / 10 C.I.
10	1	N16128	MOUNT, ACCUMULATOR W / STOPS
11	4	4460	WASHER, FLAT 1/4"
12	4	4228	WASHER, 5/16" LOCK
13	4	4237	NUT, 5/16" STANDARD
14	2	4195	BOLT, 3/8" x 1" GRADE 5
15	2	4065	WASHER, 3/8" LOCK
16	1	N16166	HOSE, 3/8" x 24" - 6FJIC - 8MOR
17	1	N24827	ELBOW, 90 DEG - 8FJIC - 8MJIC
18	1	N12444	ADAPTER, - 8MJIC - 10MOR
19	4	N28502	BOLT, 1/2" x 1 - 1/2" 12 PT GRADE 8
20	8	N16472	WASHER, 1/2" NORDLOCK
21	1	N28205	MOTOR, VARIABLE 15 BAR
22	1	N20901	ADAPTER, 900 SER LOAD 4.5 SHAFT
23	4	4013	BOLT, 1/2" x 1 - 1/2" GRADE 5
24	1	N38181	KIT, SEAL CART SUN RDFA-LCN
25	1	N14170	KIT, COUNTER BALANCE SEAL

** Use item 24, part number N38181, for seal kit for valves N28099 and N28100.

*** Use item 25, part number N14170, for seal kit for valves N28102 and N28103.

Parts Identification

Motor Assembly #1033 Closed 15 Bar (N28500)

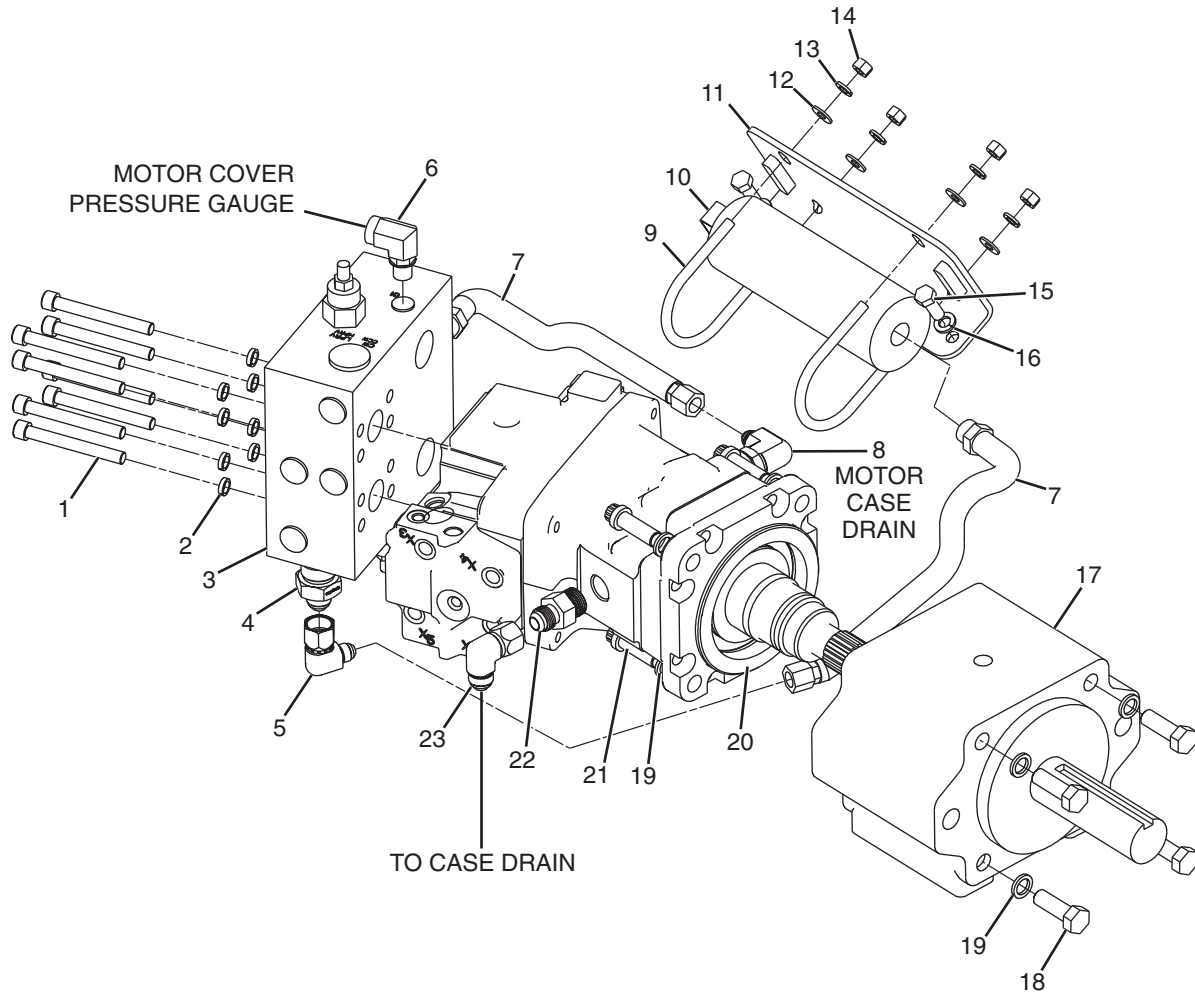

Relief Valve Open Loop CW (N28636) Schematic

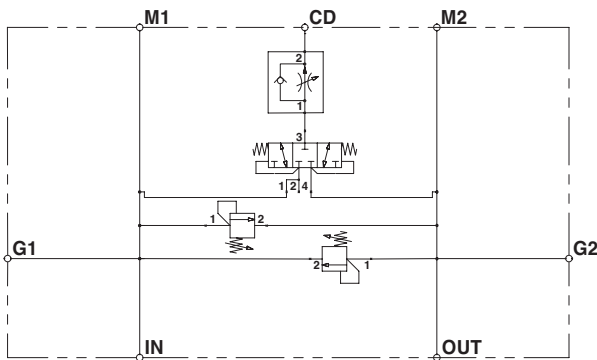

* Item 3 (N28636) parts breakdown.

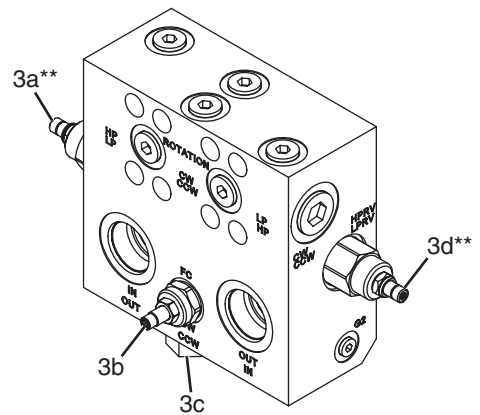

** Use item 24 in parts list, part number N38181, for seal kit for items 3a and 3d.

Parts Identification

Motor Assembly #1033 Closed 15 Bar (N28500)

#	QTY.	PART #	DESCRIPTION
1	8	N28353	BOLT, SHCS 3/8" X 3-1/4"
2	8	N21916	WASHER, HIGH COLLARLOCK 3/8"
3	1	N28636	VALVE, RELIEF CLOSED LOOP CW
3a	2	N28100**	VALVE, RELIEF LOW PRESSURE 1000 PSI
3b	1	N28098	VALVE, PURGE FLOW CONTROL
3c	1	N28101	VALVE, HOT OIL SHUTTLE
3d	1	N28099**	VALVE, RELIEF HIGH PRESSURE 5000 PSI
4	1	N29731	ADAPTER, 8MJC - 12MOR
5	1	N19068	ELBOW, 90 DEG - 6MJIC - 8FJIC
6	1	N16066	ELBOW, 6 MOR -6FP/90 DEG
7	2	N16166	HOSE, 3/8X24" (6FJX-8MOR)
8	1	N21992	ELBOW, 90 DEG - 6 MJIC - 10 MOR
9	2	N16125	U-BOLT, 5/16 X 2-1/2 X 3-1/2
10	1	N16074	ACCUMULATOR, 500PSI/10 C.I.
11	1	N16128	MOUNT, ACCUMULATOR W/STOPS
12	4	4460	WASHER, FLAT 1/4"
13	4	4228	WASHER, 5/16" LOCK
14	4	4237	NUT, 5/16" STANDARD
15	2	4195	BOLT, 3/8" X 1" GRADE 5
16	2	4065	WASHER, 3/8 LOCK
17	1	N20901	ADAPTER, 900 SER LOAD 4.5 SHAFT
18	4	4013	BOLT, 1/2" X 1-1/2" GRADE 5
19	8	N16472	WASHER, 1/2 NORDLOCK
20	1	N28205	MOTOR, VARIABLE 15BAR
21	4	N28502	BOLT, 1/2" X 1-1/2" 12PT GRD 8
22	1	N12444	ADAPTER, 8MJIC - 10MOR
23	1	N24827	ELBOW, 90 DEG - 8FJC - 8MJC
24	1	N38181	KIT, SEAL CART SUN RDFA-LCN

**Use item 24, part number N38181, for seal kit for valves N28099 and N28100.

Parts Identification

Motor Assembly, VOAC 60 (N20840)

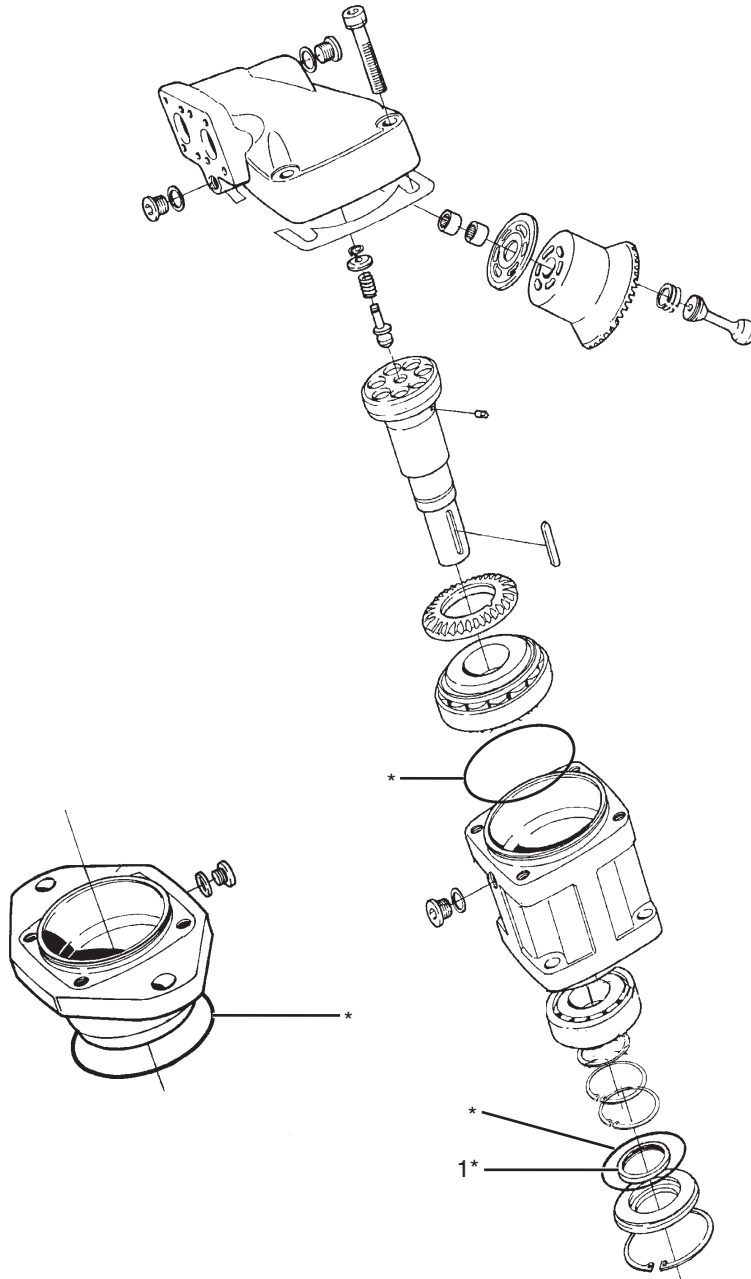

#	QTY.	PART #	DESCRIPTION
*	1	N28563	REBUILD SEAL KIT (Items with asterisk are included in seal kit.)
1*	1	N28173	SHAFT SEAL 45 X 65 X 7

Overhung Load Adapter (N20901)

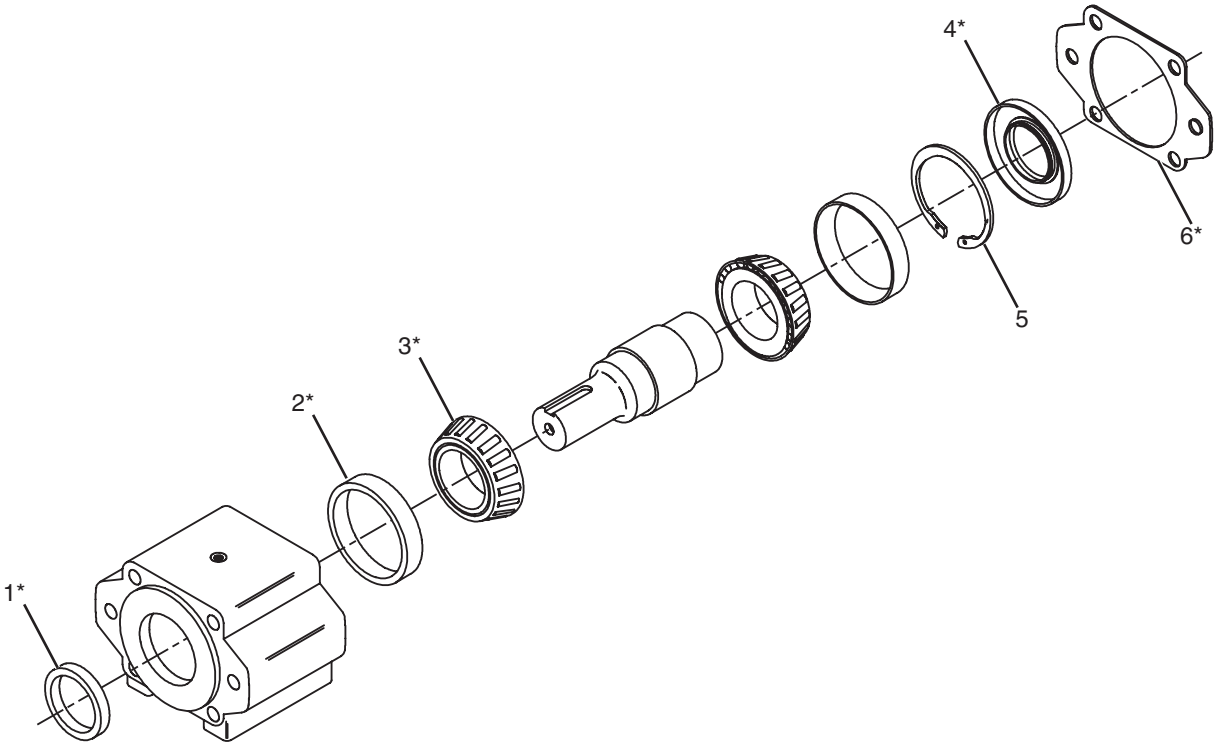

#	QTY.	PART #	DESCRIPTION
*	1	N28566	REBUILD KIT (Includes Items 1, 2, 3, 4, and 6.)
1	1	N28447	SEAL, FRONT
2	2	N34130	CUP BEARING
3	2	N34131	CONE BEARING
4	1	N28448	SEAL, REAR
5	1	N34132	RETAINING RING
6	1	N14159	GASKET

Parts Identification

Variable Motor Assembly, 15 Bar (N28205)

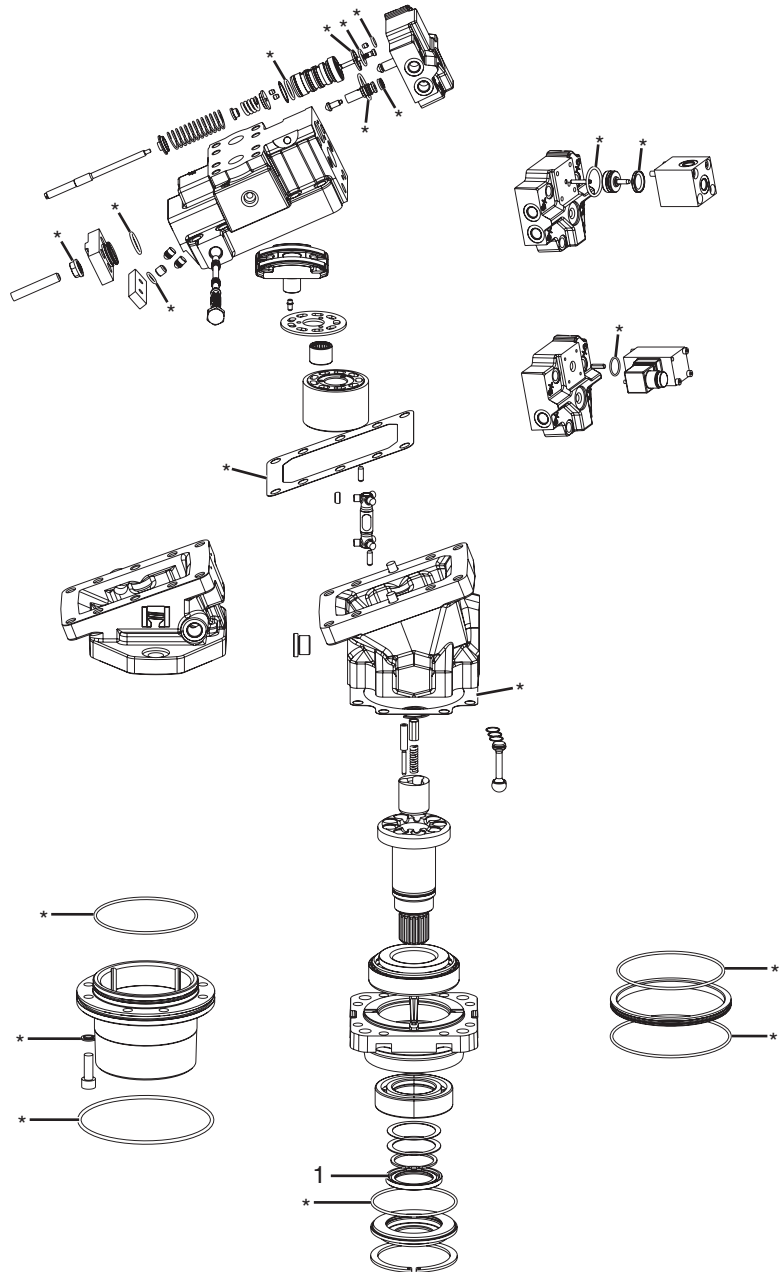

#	QTY.	PART #	DESCRIPTION
*	1	N28560	REBUILD SEAL KIT (Items with asterisk are included in seal kit.)
1	1	N28173	SHAFT SEAL 60 X 80 X 7

Hydraulic Hose Assembly (N28471)

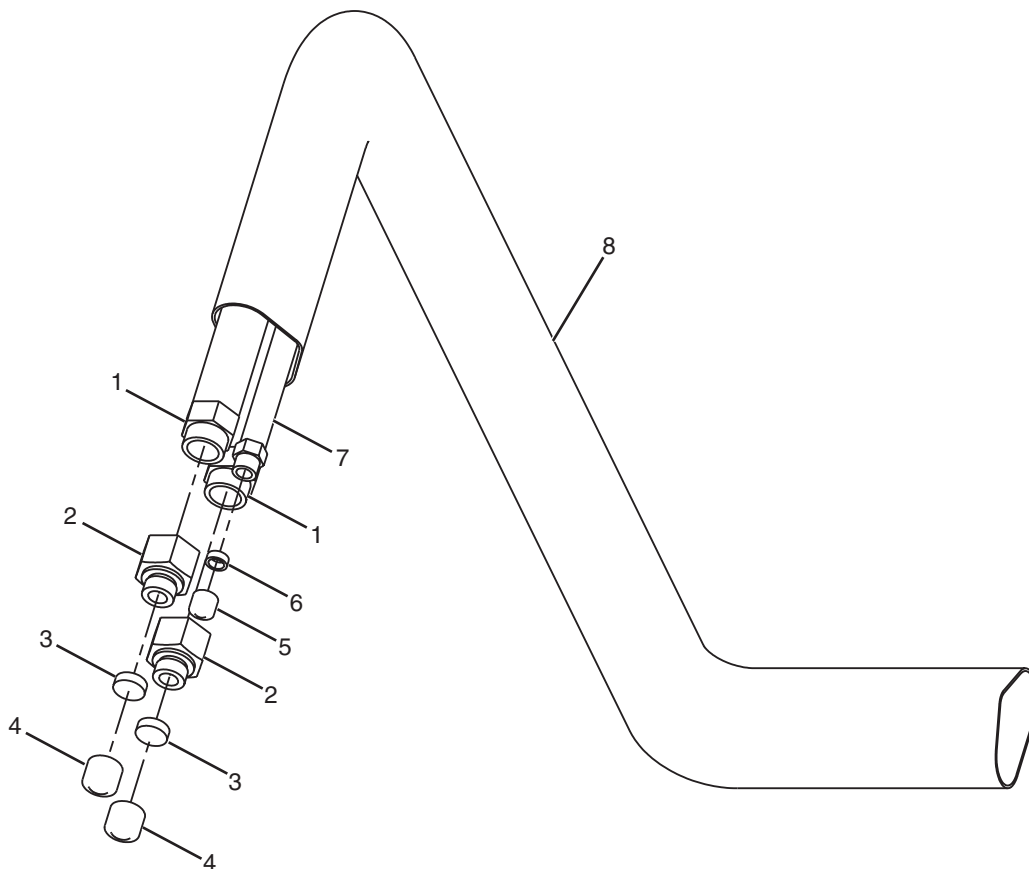

#	QTY.	PART #	DESCRIPTION
1	2	N28273	HOSE, 1" X 126" HYD W/O SLEEVE -16MORB B.E.
2	2	N28108	ADAPTER, - 12MOR - 16FOR
3	2	N32001	PLUG, 1.00 X .3125
4	2	N15893	CAP, 3/4" ALUMINUM HOSE
5	1	N15895	CAP, 1/2 ALUMINUM HOSE
6	1	N32002	PLUG, 3/8 SCH 40 X .25
7	1	N28358	HOSE, 1/2" X 144"-8FJIC -8MORB
8	1	N28352	SLEEVE, HOSE 4.75 X 8'6"

Parts Identification

Belt Tensioner (N28018)

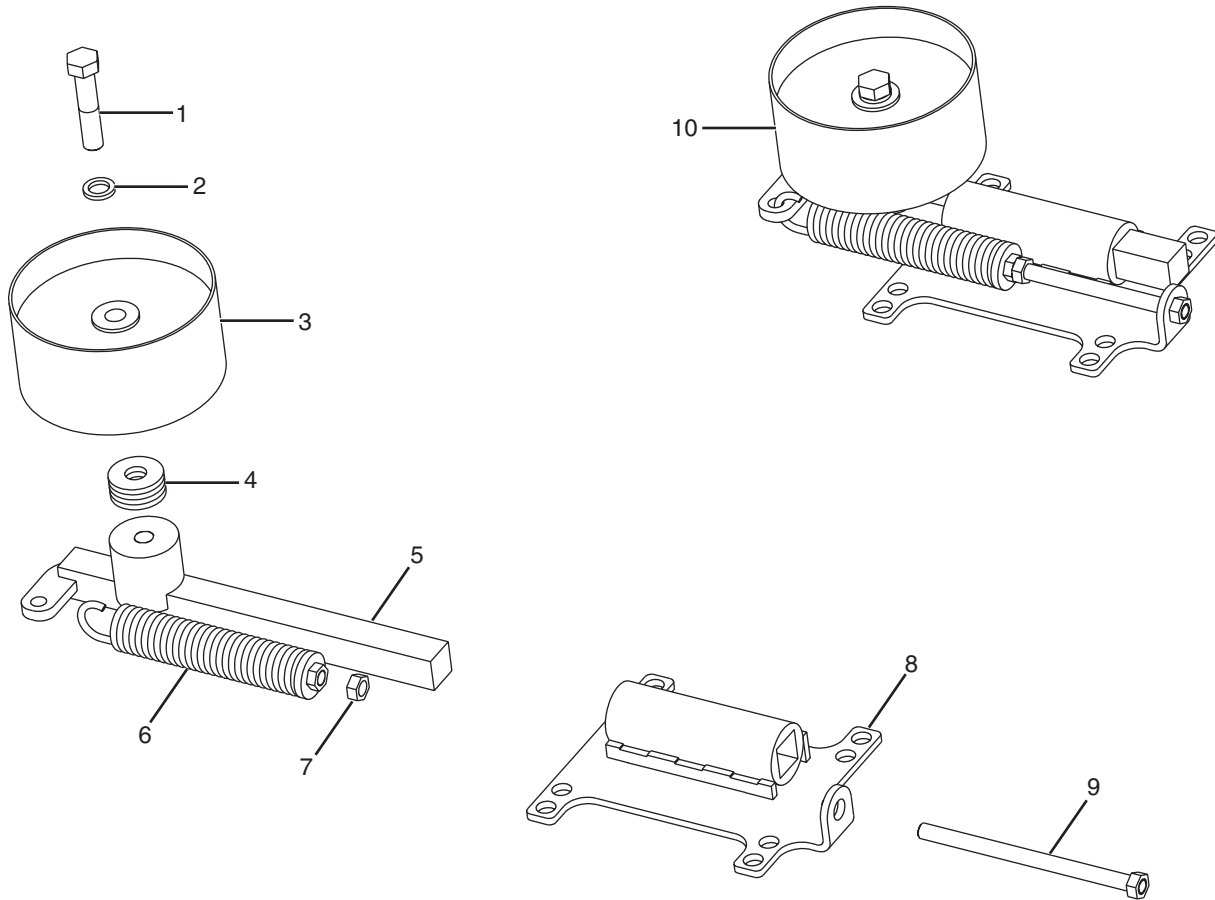

#	QTY.	PART #	DESCRIPTION
1	1	4459	BOLT, 5/8" x 3" GRADE 8
2	1	N16473	WASHER, 5/8" NORDLOCK
3	1	N10508	PULLEY, IDLER BELT
4	Varies	N28269	WASHER, HARDENED 5/8" x 1 - 3/4"
5	1	N28382	SLIDE, BELT TIGHT SQ ASSY
6	1	N24211	SPRING, BELT TIGHTENER
7	1	4250	NUT, STANDARD 1/2"
8	1	N28019	BASE, BELT TIGHT SQ SLIDE
9	1	N24596	ROD, THREADED 1/2" x 7.66" W / NUT
10	1	N28018	TENSIONER, BELT 4 BAND

Motor Shield W / Gauge (N15974)

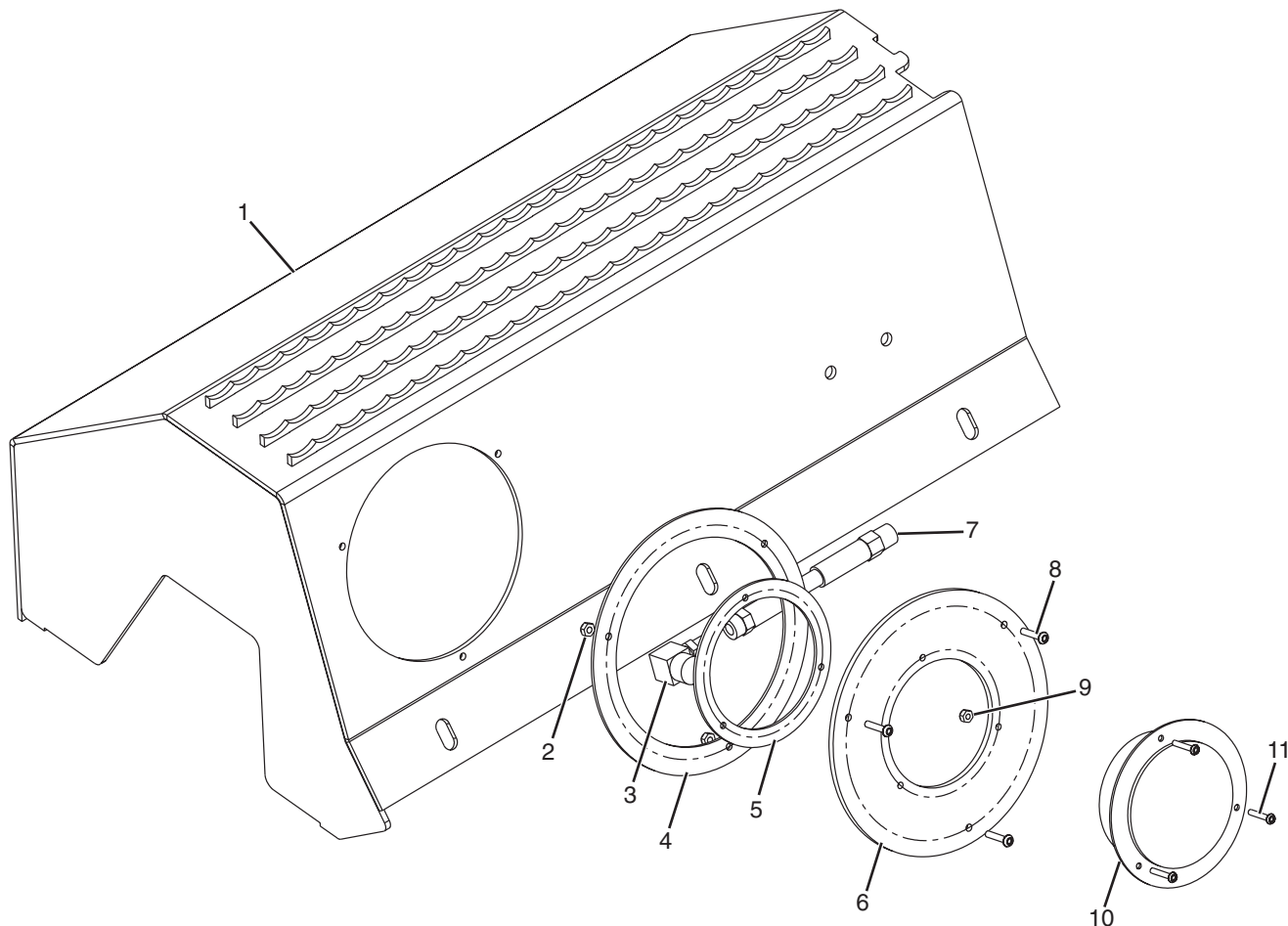

#	QTY.	PART #	DESCRIPTION
1	1	N20209	SHIELD, CARBIDE MOTOR
2	3	N16334	NUT, NYLON INSERT #10
3	1	N16162	ELBOW, 1/4" NPT 90 DEG STREET
4	1	N16335	FLANGE, MOUNT #10
5	1	N16331	FLANGE, MOUNT GAUGE #8
6	1	N16332	FLANGE, MOUNT GAUGE
7	1	N16067	HOSE, 1/4" x 24" x 5000 PSI
8	3	N16333	BOLT, BHCS #10 - 32 x 1"
9	3	N16133	NUT, NYLON INSERT #8
10	1	N16163	GAUGE, 0 - 6000 PSI 4" PRESS
11	3	N16132	BOLT, BHCS #8 - 32 x 1"

Parts Identification

Rotor (W / Double Carbide Teeth) 51" (N20083), 61" (N20077), 71" (N20080)

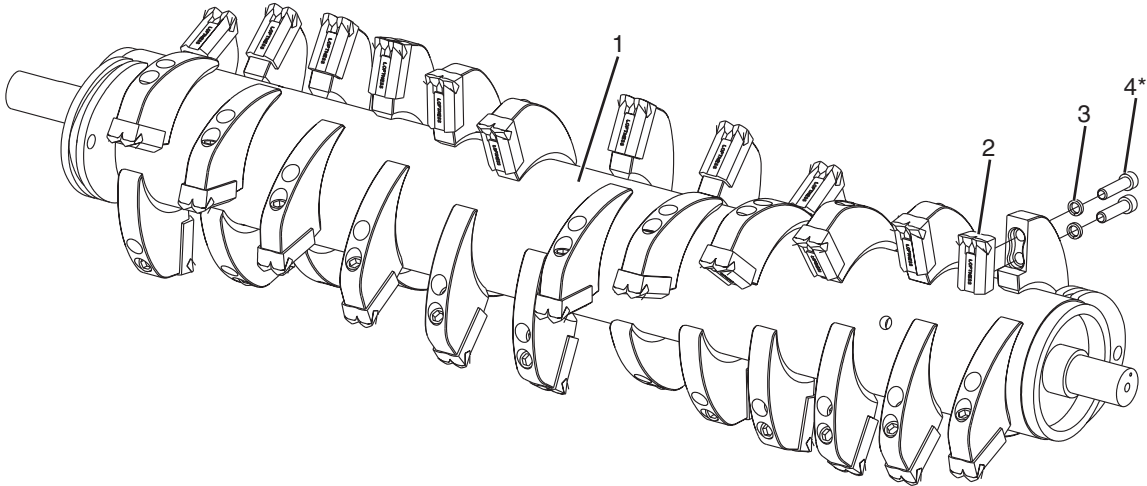

* Use copper based anti-seize.
Torque to 137 ft.-lbs.
Tighten top bolt (Item 4) first.

#	QTY.	PART #	DESCRIPTION
1	1	N20084	ROTOR, 51" CARBIDE SPIRAL W / O CUTTERS
	1	N20078	ROTOR, 61" CARBIDE SPIRAL W / O CUTTERS
	1	N20081	ROTOR, 71" CARBIDE SPIRAL W / O CUTTERS
2	30	N15510	TOOTH, DOUBLE CARBIDE (51")
	36	N15510	TOOTH, DOUBLE CARBIDE (61")
	42	N15510	TOOTH, DOUBLE CARBIDE (71")
3	60	N17041	WASHER, LOCK 5/8" (51")
	72	N17041	WASHER, LOCK 5/8" (61")
	84	N17041	WASHER, LOCK 5/8" (71")
4	60	N15646	SCREW, 5/8" - 18UNF x 2 - 1/2" GR 8 (51")
	72	N15646	SCREW, 5/8" - 18UNF x 2 - 1/2" GR 8 (61")
	84	N15646	SCREW, 5/8" - 18UNF x 2 - 1/2" GR 8 (71")

Parts Identification

Rotor (W / Carbide Planer Teeth) (Optional) 51" (N20576), 61" (N20575), 71" (N21906)

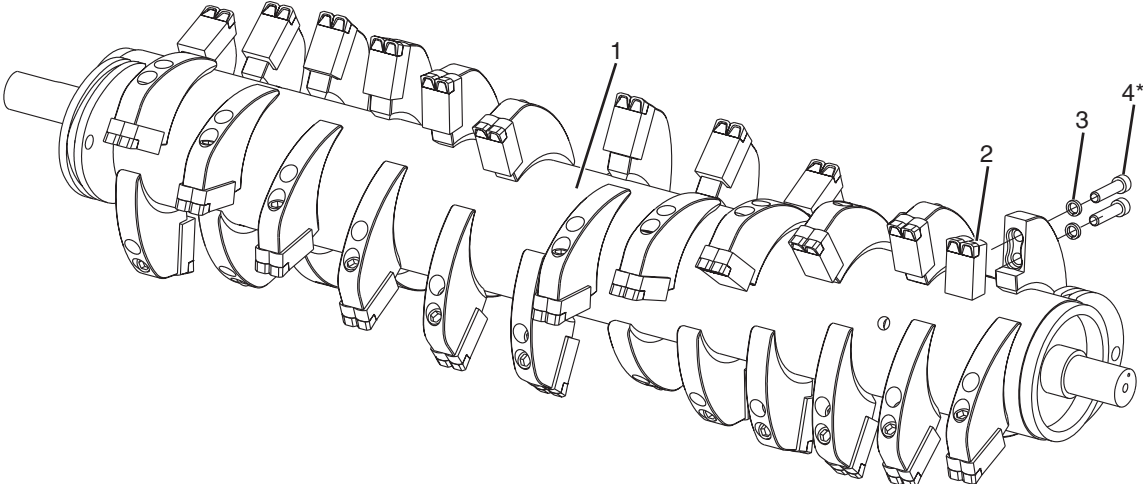

*** Use copper based anti-seize.
Torque to 137 ft.-lbs.
Tighten top bolt (Item 4) first.**

#	QTY.	PART #	DESCRIPTION
1	1	N20084	ROTOR, 51" CARBIDE SPIRAL W / O CUTTERS
	1	N20078	ROTOR, 61" CARBIDE SPIRAL W / O CUTTERS
	1	N20081	ROTOR, 71" CARBIDE SPIRAL W / O CUTTERS
2	30	N17044	TOOTH, CARBIDE DOUBLE PLANER (51")
	36	N17044	TOOTH, CARBIDE DOUBLE PLANER (61")
	42	N17044	TOOTH, CARBIDE DOUBLE PLANER (71")
3	60	N17041	WASHER, LOCK 5/8" (51")
	72	N17041	WASHER, LOCK 5/8" (61")
	84	N17041	WASHER, LOCK 5/8" (71")
4	60	N15646	SCREW, 5/8" - 18UNF x 2 - 1/2" GR 8 (51")
	72	N15646	SCREW, 5/8" - 18UNF x 2 - 1/2" GR 8 (61")
	84	N15646	SCREW, 5/8" - 18UNF x 2 - 1/2" GR 8 (71")

Parts Identification

Rotor (W / Quadco Planer Teeth) (Optional) 51" (N24689), 61" (N28165), 71" (N28168)

* Use copper based anti-seize.
Torque to 137 ft.-lbs.
Tighten top bolt (Item 5) first.

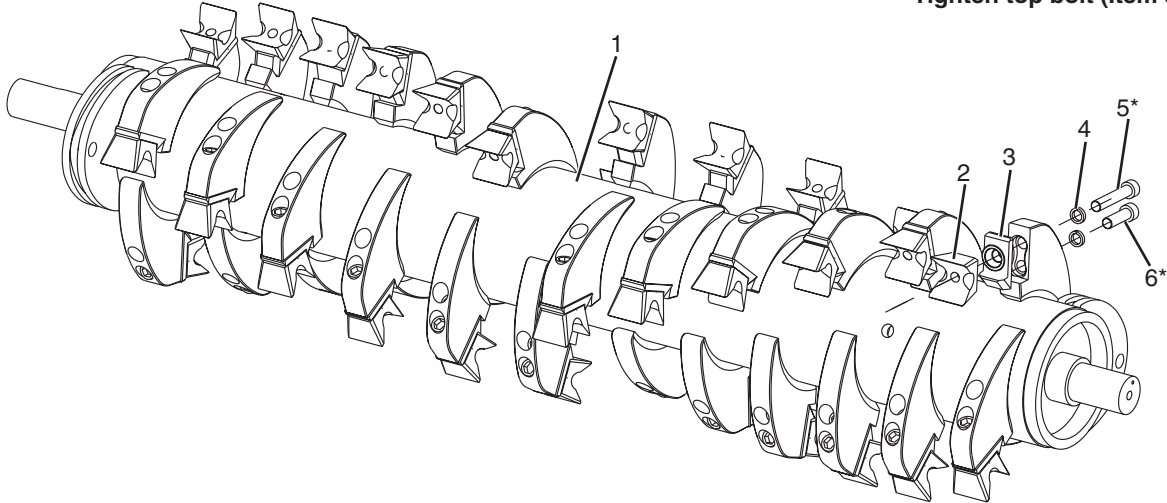

#	QTY.	PART #	DESCRIPTION
1	1	N20084	ROTOR, 51" CARBIDE SPIRAL W / O CUTTERS
	1	N20078	ROTOR, 61" CARBIDE SPIRAL W / O CUTTERS
	1	N20081	ROTOR, 71" CARBIDE SPIRAL W / O CUTTERS
2	30	N24279	TOOTH, QUADCO PLANER (51")
	36	N24279	TOOTH, QUADCO PLANER (61")
	42	N24279	TOOTH, QUADCO PLANER (71")
3	30	N24139	HOLDER, TOOTH QUADCO PLANER (51")
	36	N24139	HOLDER, TOOTH QUADCO PLANER (61")
	42	N24139	HOLDER, TOOTH QUADCO PLANER (71")
4	60	N17041	WASHER, LOCK 5/8" (51")
	72	N17041	WASHER, LOCK 5/8" (61")
	84	N17041	WASHER, LOCK 5/8" (71")
5	30	N26490	SCREW, 5/8" - 18UNF x 3 - 1/4" GR 8 (51")
	36	N26490	SCREW, 5/8" - 18UNF x 3 - 1/4" GR 8 (61")
	42	N26490	SCREW, 5/8" - 18UNF x 3 - 1/4" GR 8 (71")
6	30	N17036	SCREW, 5/8" - 18UNF x 2" GR 8 (51")
	36	N17036	SCREW, 5/8" - 18UNF x 2" GR 8 (61")
	42	N17036	SCREW, 5/8" - 18UNF x 2" GR 8 (71")

Tooth Assembly, Quadco Planer (N24281)

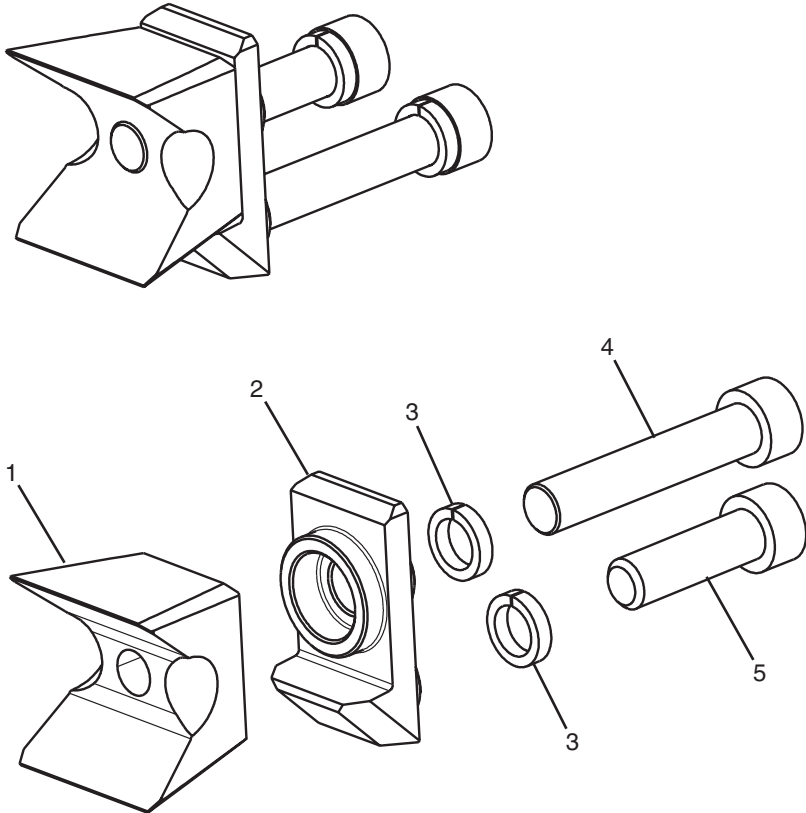

#	QTY.	PART #	DESCRIPTION
1	1	N24279	TOOTH, QUADCO PLANER
2	1	N24139	HOLDER, TOOTH QUADCO PLANER
3	2	N17041	WASHER, LOCK 5/8"
4	1	N26490	SCREW, SHCS 5/8"-18UNF X 3-1/4"
5	1	N17036	SCREW, SHCS 5/8"-18UNF X 2"

Parts Identification

Rear Cutter Bar 51" (N20282), 61" (N20281), 71" (N21908)

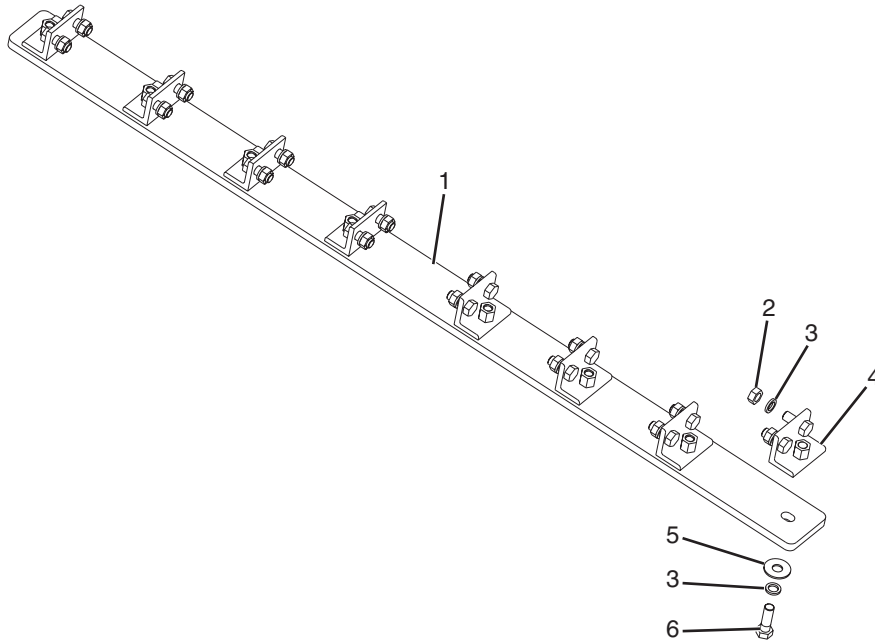

#	QTY.	PART #	DESCRIPTION
1	1	N20264	PLATE, 51" CARBIDE CUTTER
	1	N20238	PLATE, 61" CARBIDE CUTTER
	1	N21909	PLATE, 71" CARBIDE CUTTER
2	14	4452	NUT, 5/8" - 18UNF STANDARD FINE THREAD (51")
	16	4452	NUT, 5/8" - 18UNF STANDARD FINE THREAD (61")
	18	4452	NUT, 5/8" - 18UNF STANDARD FINE THREAD (71")
3	21	N16473	WASHER, 5/8" NORDLOCK (51")
	24	N16473	WASHER, 5/8" NORDLOCK (61")
	27	N16473	WASHER, 5/8" NORDLOCK (71")
4	7	N20247	MOUNT, CARBIDE REAR CUTTER ANGLE (51")
	8	N20247	MOUNT, CARBIDE REAR CUTTER ANGLE (61")
	9	N20247	MOUNT, CARBIDE REAR CUTTER ANGLE (71")
5	7	4069	WASHER, FLAT 5/8" (51")
	8	4069	WASHER, FLAT 5/8" (61")
	9	4069	WASHER, FLAT 5/8" (71")
6	7	4042	BOLT, 5/8" x 2" FINE THRD. GR. 8 (51")
	8	4042	BOLT, 5/8" x 2" FINE THRD. GR. 8 (61")
	9	4042	BOLT, 5/8" x 2" FINE THRD. GR. 8 (71")

Machine Decals and Signs

NOTE: All safety related decals are also shown in the *Safety Instructions Section* along with their location on the machine. See "Safety Decal Locations" on page 9.

Check and replace any worn, torn, hard to read or missing decals on your machine.

NOTE: To order a complete Carbide Cutter Decal Kit use part number N28473.

Part No. N17013

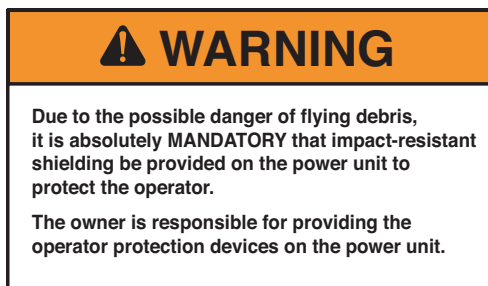

Part No. N20661

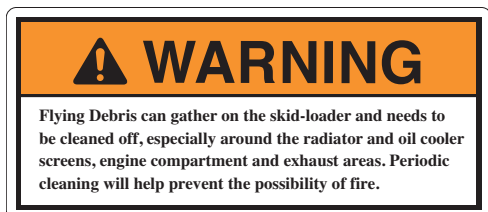

Part No. N17014

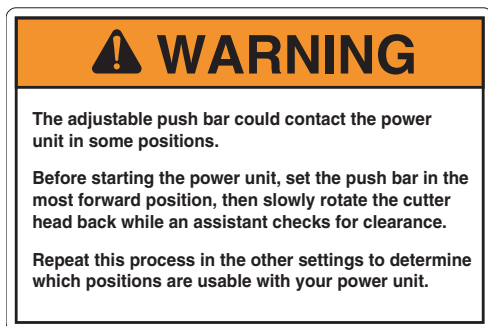

Part No. 4334



Part No. N16759

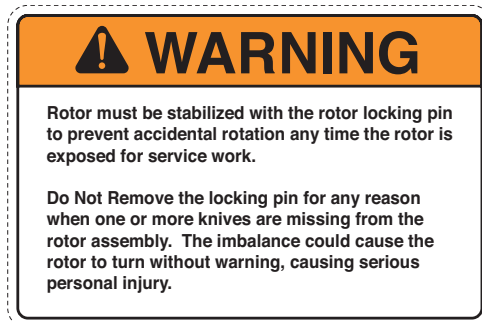

Part No. N22763

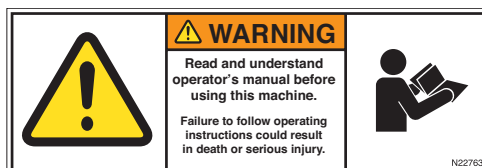

Part No. N28385

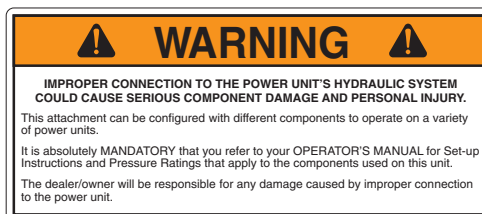

Part No. 4189



Part No. N28386



Parts Identification

Machine Decals and Signs (Cont'd)

Part No. N13863



Part No. 4256



Part No. N13872

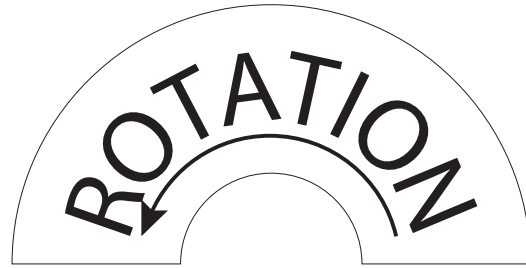

Part No. N28010

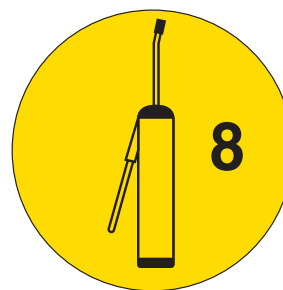

Part No. N28012

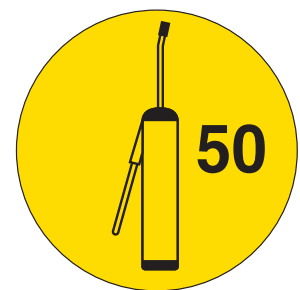

Part No. N13721



Machine Decals and Signs (Cont'd)

Part No. N26973



Part No. N28577



Part No. N28504



Part No. N28505



Part No. N33105



Part No. N13517



Part No. 4138





Specifications

DESCRIPTION	CARBIDE CUTTER
Cutting Width	51 in. (129.5 cm)
	61 in. (154.9 cm)
	71 in. (180.3 cm)
Operating Capacity	6 in. (15.2 cm) Continuous
	10 in. (25.4 cm) Intermittent
Capacity Monitor	Pressure Gauge
Motor	Fixed Piston (#5 & #6 Hyd Systems)
	Variable Displacement, (#9 & #10 Hyd Systems)
Rotor Bearing	2.1875 in. Piloted Double Taper
Rotor Tip Diameter	17 in. (43.2 cm)
Sheaves	Taperlock
Belt	Four Band 5VX Type
Belt Tightener	Spring Loaded Tensioner
Mount	Universal Skid Type
Shear Bar	Adjustable
Pusher Bar	Adjustable Rigid Bar
Knives	Double Carbide Teeth
	Double Carbide Planer Teeth (Optional)
	Quadco Planer Teeth, Sharpenable (Optional)
Skid Shoes	Adjustable 1 in. (2.5 cm) - 3 in. (7.6 cm)
Deflector	Steel Chain
Anti-Wrap Protection	Bearing

Appendix

Dimensions

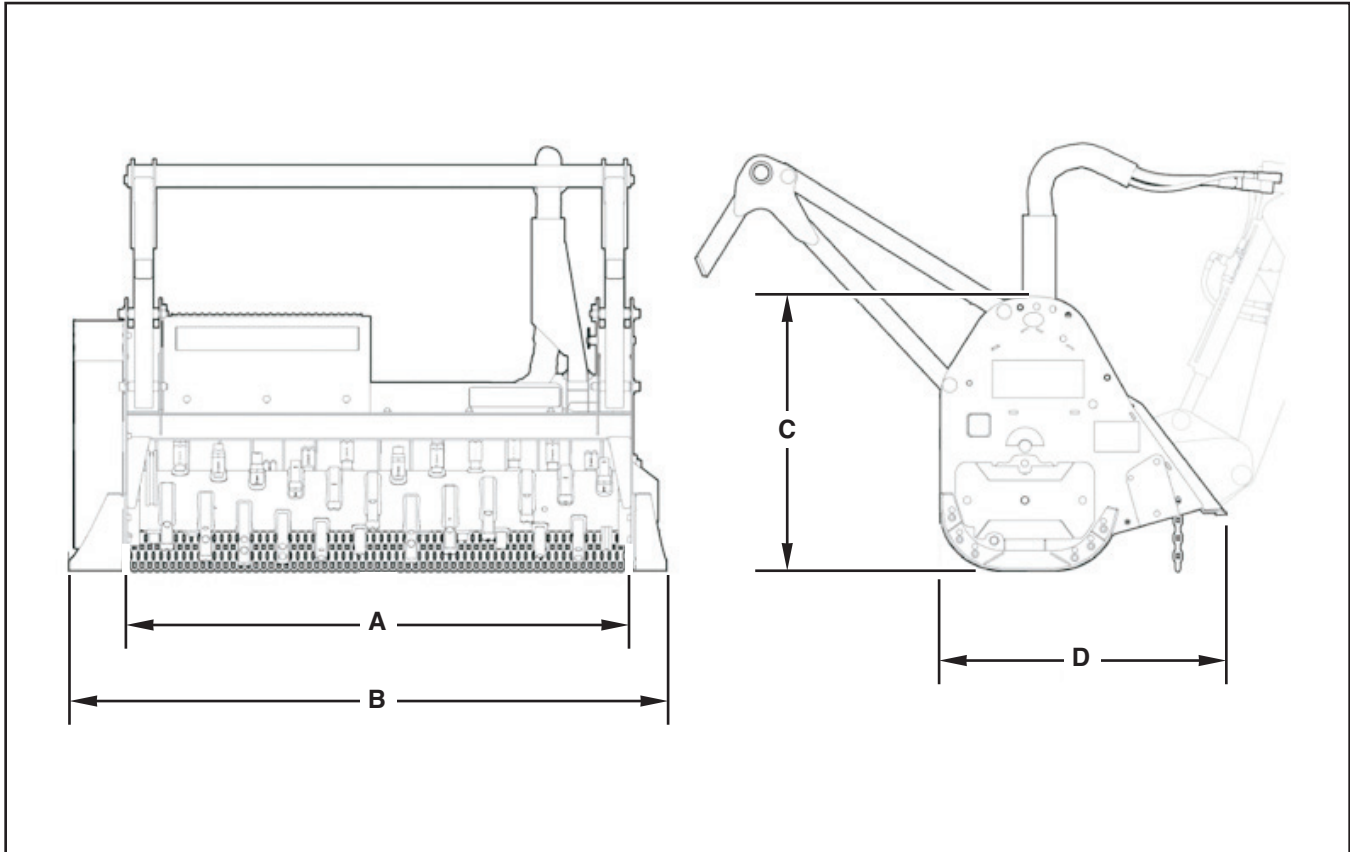

DESCRIPTION	CARBIDE CUTTER		
	51	61	71
Cutting Width (A)	51.02 in. (129.59 cm)	61.02 in. (154.99 cm)	71.02 in. (180.39 cm)
Overall Width (B)	68.56 in. (174.14 cm)	78.56 in. (199.54 cm)	88.56 in. (224.94 cm)
Operating Height (C)	35.81 in. (90.96 cm)	35.81 in. (90.96 cm)	35.81 in. (90.96 cm)
Overall Length (D)	37.17 in. (94.41 cm)	37.17 in. (94.41 cm)	37.17 in. (94.41 cm)
Number Of Knives	30	36	42
Weight	2145 lb. (973 kg)	2277 Lb. (1033 kg)	2409 lb. (1093 kg)
Crated Weight	2415 lb. (1095 kg)	2577 Lb. (1169 kg)	2759 lb. (1251 kg)

Torque Specifications

Inches Hardware and Lock Nuts

TORQUE CHARTS

Minimum Hardware Tightening Torques

Normal Assembly Applications
(Standard Hardware and Lock Nuts)

SAE Gr. 2 Nominal Size	SAE Grade 5		SAE Grade 8		LOCK NUTS			
	Unplated or Plated Silver	Plated W / ZnCr Gold	Unplated or Plated Silver	Plated W / ZnCr Gold	Unplated or Plated Silver	Plated W / ZnCr Gold	Grade W / Gr. 5 Bolt	Grade W / Gr. 8 Bolt
1/4	55 in.-lb. (6.2 N•m)	72 in.-lb. (8.1 N•m)	86 in.-lb. (9.7 N•m)	112 in.-lb. (12.6 N•m)	121 in.-lb. (13.6 N•m)	157 in.-lb. (17.7 N•m)	61 in.-lb. (6.9 N•m)	86 in.-lb. (9.8 N•m)
5/16	115 in.-lb. (13 N•m)	149 in.-lb. (17 N•m)	178 in.-lb. (20 N•m)	229 in.-lb. (26 N•m)	250 in.-lb. (28 N•m)	324 in.-lb. (37 N•m)	125 in.-lb. (14 N•m)	176 in.-lb. (20 N•m)
3/8	17 ft.-lb. (23 N•m)	22 ft.-lb. (30 N•m)	26 ft.-lb. (35 N•m)	34 ft.-lb. (46 N•m)	37 ft.-lb. (50 N•m)	48 ft.-lb. (65 N•m)	19 ft.-lb. (26 N•m)	26 ft.-lb. (35 N•m)
7/16	27 ft.-lb. (37 N•m)	35 ft.-lb. (47 N•m)	42 ft.-lb. (57 N•m)	54 ft.-lb. (73 N•m)	59 ft.-lb. (80 N•m)	77 ft.-lb. (104 N•m)	30 ft.-lb. (41 N•m)	42 ft.-lb. (57 N•m)
1/2	42 ft.-lb. (57 N•m)	54 ft.-lb. (73 N•m)	64 ft.-lb. (87 N•m)	83 ft.-lb. (113 N•m)	91 ft.-lb. (123 N•m)	117 ft.-lb. (159 N•m)	45 ft.-lb. (61 N•m)	64 ft.-lb. (88 N•m)
9/16	60 ft.-lb. (81 N•m)	77 ft.-lb. (104 N•m)	92 ft.-lb. (125 N•m)	120 ft.-lb. (163 N•m)	130 ft.-lb. (176 N•m)	169 ft.-lb. (229 N•m)	65 ft.-lb. (88 N•m)	92 ft.-lb. (125 N•m)
5/8	83 ft.-lb. (112 N•m)	107 ft.-lb. (145 N•m)	128 ft.-lb. (174 N•m)	165 ft.-lb. (224 N•m)	180 ft.-lb. (244 N•m)	233 ft.-lb. (316 N•m)	90 ft.-lb. (122 N•m)	127 ft.-lb. (172 N•m)
3/4	146 ft.-lb. (198 N•m)	189 ft.-lb. (256 N•m)	226 ft.-lb. (306 N•m)	293 ft.-lb. (397 N•m)	319 ft.-lb. (432 N•m)	413 ft.-lb. (560 N•m)	160 ft.-lb. (217 N•m)	226 ft.-lb. (306 N•m)
7/8	142 ft.-lb. (193 N•m)	183 ft.-lb. (248 N•m)	365 ft.-lb. (495 N•m)	473 ft.-lb. (641 N•m)	515 ft.-lb. (698 N•m)	667 ft.-lb. (904 N•m)	258 ft.-lb. (350 N•m)	364 ft.-lb. (494 N•m)
1	213 ft.-lb. (289 N•m)	275 ft.-lb. (373 N•m)	547 ft.-lb. (742 N•m)	708 ft.-lb. (960 N•m)	773 ft.-lb. (1048 N•m)	1000 ft.-lb. (1356 N•m)	386 ft.-lb. (523 N•m)	545 ft.-lb. (739 N•m)

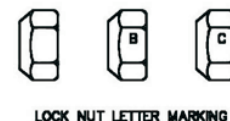
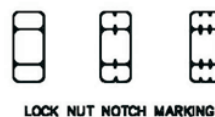
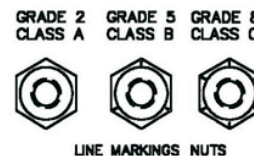
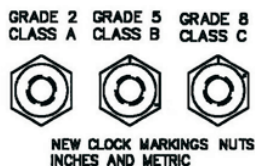
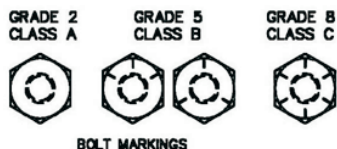

Appendix

Torque Specifications (Cont'd)

Metric Hardware and Lock Nuts

TORQUE CHARTS Minimum Hardware Tightening Torques

Normal Assembly Applications
(Metric Hardware and Lock Nuts)

Nominal Size	Class 5,8		Class 8,8		Class 10,9		Lock nuts
	Unplated or Plated Silver	Plated W / ZnCr Gold	Unplated or Plated Silver	Plated W / ZnCr Gold	Unplated or Plated Silver	Plated W / ZnCr Gold	Class 8 W / CL. 8,8 Bolt
M4	1.7 N•m (15 in.-lb.)	2.2 N•m (19 in.-lb.)	2.6 N•m (23 in.-lb.)	3.4 N•m (30 in.-lb.)	3.7 N•m (33 in.-lb.)	4.8 N•m (42 in.-lb.)	1.8 N•m (16 in.-lb.)
M6	5.8 N•m (51 in.-lb.)	7.6 N•m (67 in.-lb.)	8.9 N•m (79 in.-lb.)	12 N•m (102 in.-lb.)	13 N•m (115 in.-lb.)	17 N•m (150 in.-lb.)	6.3 N•m (56 in.-lb.)
M8	14 N•m (124 in.-lb.)	18 N•m (159 in.-lb.)	22 N•m (195 in.-lb.)	28 N•m (248 in.-lb.)	31 N•m (274 in.-lb.)	40 N•m (354 in.-lb.)	15 N•m (133 in.-lb.)
M10	28 N•m (21 ft.-lb.)	36 N•m (27 ft.-lb.)	43 N•m (32 ft.-lb.)	56 N•m (41 ft.-lb.)	61 N•m (45 ft.-lb.)	79 N•m (58 ft.-lb.)	30 N•m (22 ft.-lb.)
M12	49 N•m (36 ft.-lb.)	63 N•m (46 ft.-lb.)	75 N•m (55 ft.-lb.)	97 N•m (72 ft.-lb.)	107 N•m (79 ft.-lb.)	138 N•m (102 ft.-lb.)	53 N•m (39 ft.-lb.)
M16	121 N•m (89 ft.-lb.)	158 N•m (117 ft.-lb.)	186 N•m (137 ft.-lb.)	240 N•m (177 ft.-lb.)	266 N•m (196 ft.-lb.)	344 N•m (254 ft.-lb.)	131 N•m (97 ft.-lb.)
M20	237 N•m (175 ft.-lb.)	307 N•m (226 ft.-lb.)	375 N•m (277 ft.-lb.)	485 N•m (358 ft.-lb.)	519 N•m (383 ft.-lb.)	671 N•m (495 ft.-lb.)	265 N•m (195 ft.-lb.)
M24	411 N•m (303 ft.-lb.)	531 N•m (392 ft.-lb.)	648 N•m (478 ft.-lb.)	839 N•m (619 ft.-lb.)	897 N•m (662 ft.-lb.)	1160 N•m (855 ft.-lb.)	458 N•m (338 ft.-lb.)

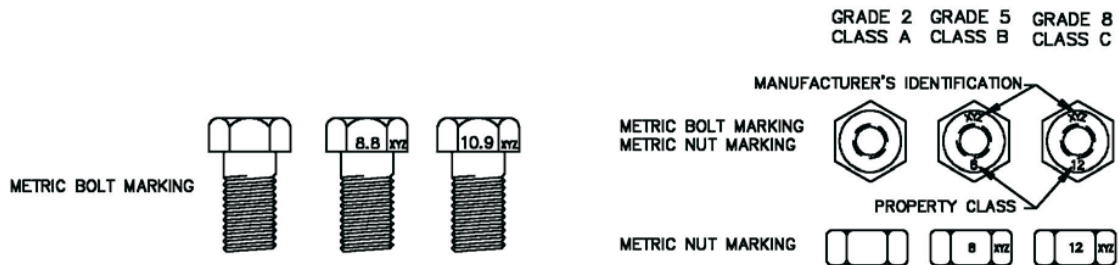

NOTE: CLASS 2 IN METRIC IS 5.8



www.loftness.com

Loftness Specialized Equipment, Inc.
650 So. Main Street • PO Box 337 • Hector, MN 55342
Tel: 320.848.6266 • Fax: 320.848.6269 • Toll Free: 1.800.828.7624

Printed in USA
© Loftness 2014